



Uponor

SNOW AND ICE
MELTING

DESIGN AND
INSTALLATION MANUAL



This manual is published for contractors, architects, engineers and building officials interested in Uponor Snow and Ice Melting systems. This manual describes the design process and application of snow and ice melting systems that use Wirsbo hePEX™, Uponor AquaPEX® and Multi-layer Composite (MLC) tubing products.

Please direct any questions regarding the suitability of an application or a specific design to your local Uponor representative. For the name of your local representative, contact Uponor Customer Service at 888.594.7726 (U.S.) or 888.994.7726 (Canada).

Snow and Ice Melting Design and Installation Manual

is published by

Uponor, Inc.

5925 148th Street West
Apple Valley, MN 55124 USA
Tel: 800.321.4739
Fax: 952.891.2008

uponorpro.com
uponorengineering.com

Uponor Ltd.

2000 Argentia Rd., Plaza 1, Ste. 200
Mississauga, ON L5N 1W1 CANADA
Tel: 888.994.7726
Fax: 800.638.9517

uponorpro.com
uponorengineering.com

© 2015 Uponor
All rights reserved.

Fourth Edition
First Printing 1994
Printed in the United States of America

Uponor has used reasonable efforts in collecting, preparing and providing quality information and material in this manual. However, system enhancements may result in modification of features or specifications without notice.

Uponor is not liable for installation practices that deviate from this manual or are not acceptable practices within the mechanical trades.

Table of Contents

Chapter 1	Glossary	3
Chapter 2	Introduction	7
Chapter 3	Uponor Tubing Products and Hardware	9
Chapter 4	Installation Methods	19
Chapter 5	Design Considerations	31
Chapter 6	Design Tutorial	39
Chapter 7	Control Strategies	43
Chapter 8	Piping and Electrical Schematics	47

Appendices

Appendix A	Design Analysis Worksheet	57
Appendix B	Manifold Worksheet	59
Appendix C	System Performance and Flow Charts	61
Appendix D	Uponor PEX-a Hydronic Friction Loss Tables	69
Appendix E	MLC Hydronic Friction Loss Tables	107
Appendix F	HDPE Hydronic Friction Loss Tables	137
Appendix G	Velocity Charts	141
Appendix H	Variable Speed Injection Mixing	145
Appendix I	Conversion Factors	149

Chapter 1

Glossary



It is important to be familiar with the terminology used in this manual to fully understand the design and installation of hydronic snow and ice melting systems. Some of the definitions found in this chapter are unique to hydronic snow and ice melting systems and some may be applicable only to Uponor systems.

ASTM — American Society for Testing and Materials. Publishes standard specifications for terminology, labeling, testing and production.

Active Loop Length — The length of tubing within the total loop length that is physically installed for the snow-melt area.

Automatic Operation — A snow and ice melting control strategy that automatically operates the system to remove snow and ice without the interaction of the owner or facility manager.

BTU (British Thermal Unit) — A unit of measure equal to the amount of energy necessary to raise the temperature of one pound of water one degree Fahrenheit.

BTU/h — The amount of BTU expended per hour.

BTU/h/ft² — The amount of BTU expended per hour per square foot of panel. BTU/h/ft² is derived by dividing the BTU/h by the amount of available square footage of panel to be heated.

Bypass Loop — A piping arrangement that directs the flow of a heat-absorbing medium (e.g., water) around rather than through a piece of mechanical equipment.

Closed Loop — Any piping arrangement in a circulating system that protects the circulating medium (e.g., water) against exposure to atmospheric pressure.

Closed System — Any closed-loop hydronic tubing system which prevents atmospheric oxygen from entering the system to a degree which effectively protects components from excessive oxidative corrosion. (See the definition for DIN 4726.)

Conduction — A process of heat transfer where heat moves through a material or between two materials that are in direct contact with each other.

Constant Idle Operation — A snow and ice melting system that maintains continuous or minimum slab temperature. From this idle mode temperature, the slab can quickly accelerate to the snow and ice melting temperature when moisture is present on the slab surface.

Convection — Transfer of heat by movement of a liquid or a gas. For example, natural convection is a result of movement caused by changes in density as temperature changes within a fluid medium such as a liquid or a gas. Forced convection is the result of mechanical force moving a fluid or gas.

Crosslinking — A chemical process that changes the molecular structure of a polymer material by linking otherwise independent hydrocarbon chains. Crosslinking creates a three-dimensional network of hydrocarbons. The end product is insoluble and is incapable of being melted.

DIN — Abbreviation for the German Institute of Standards (Deutsches Institut für Normung).

DIN 4726 — An internationally recognized standard that prescribes, among other things, the maximum rate of oxygen diffusion allowed for non-metallic pipes used in closed-loop hydronic heating systems.

Design Temperature — Equal to the coldest outdoor temperature at which the system will melt snow and ice (in conjunction with snow and ice melting wind speed).

Differential Temperature (ΔT) — The difference in temperature between two opposing masses used to describe the potential that exists for heat transfer.

Diffusion — A penetration process that describes the tendency of gas or liquid molecules to spread out into the entire space available (including the spaces that exist within solids, like concrete). Diffusion is expressed as a function of the volume of space that is available. A related process, permeation, describes the movement of such substances through solid membrane and is expressed in terms of the area of membrane penetrated.

Downward Loss — The amount of heat energy in BTU/h/ft² transferring downward from the heated slab.

Edge Area — The exposed surface of a radiant heated slab equal to the thickness of the slab multiplied by the exposed linear perimeter length.

Edge Insulation — The amount of insulation (expressed in R-value) placed vertically along the exposed perimeter of the slab.

Emission — A measure of the propensity of a surface to radiate heat energy to its surroundings in the form of long-wave radiation.

Engel Method — A peroxide-based method of manufacturing crosslinked polyethylene (PEX) tubing. Engel-method PEX is crosslinked during the extrusion process while the raw polyethylene is above its crystal melting temperature, creating an even and consistent three-

dimensional network of joined hydrocarbons.

Exposed Perimeter Insulation — The amount of insulation (expressed in R-value) placed horizontally to a distance of 4 feet along an exposed perimeter of a heated slab.

Exposed Perimeter Length — Equal to the linear feet of exposed perimeter.

Extrusion — A method used for the continuous formation of tubing from polymer materials.

Floating Action — Output used to modulate the position of an actuator motor and mixing valve. Power is applied to drive the valve further open or closed. If no power is supplied, the valve will remain in its present position.

HDPE — Abbreviation for high-density polyethylene.

Head Pressure Loss — The pressure available at the outlet side of a pump or inlet side of a flow-conducting system. It is expressed in feet of head. Feet of head is the height of a column of water that can be supported by a pump against standard atmospheric pressure.

Heating Load — The amount of energy (in BTU/h) required for the entire snow and ice melting system.

Injection Mixing — A method of resetting radiant system water by injecting hot boiler water into a lower temperature distribution loop in order to maintain proper supply water temperature. In addition, injection mixing can allow for changes in supply water temperatures based on changes in outside weather conditions. Injection mixing can be controlled through either an on/off valve or variable speed injection pumping using a simple wet-rotor type circulator. Refer to **Appendix H: Variable Speed Injection Mixing** for more information.

Leader Loop Length — The horizontal and vertical distance from the area being heated to the manifold in which the loop originated. This distance is multiplied by two (supply and return) and added to the active loop length to obtain the total loop length.

Linear Expansion (thermal) — Refers to the physical material characteristic of a body which causes it to expand in the presence of heat. It is known as heat expansion. Linear expansion creates a force within the product which, if held back by huge compressive strengths such as concrete, will transmit itself as an internal stress. Unlike other tubing products, PEX is highly resistant to stresses caused by linear expansion.

Olefins — Unsaturated hydrocarbon substances (double bond). The most important building blocks (monomers) of the olefins are ethylene, propylene and butylene.

Open System — A circulating hydronic system exposed to atmospheric conditions. Open systems require components resistant to oxidative corrosion. Open systems are the result of continual introduction of fresh water, open vessels or oxygen diffusion through non-metallic components.

Outdoor Design Temperature — Equal to the coldest outdoor temperature at which the system will melt snow and ice. Designs are based on outdoor design temperature and wind speed.

PE — Abbreviation for polyethylene.

PEX — Abbreviation for crosslinked polyethylene.

Perimeter Area — The first 4 horizontal feet in from the exposed perimeter of the slab. Applicable in discussions concerning under-slab insulation.

Perimeter Insulation — The amount of insulation (expressed in R-value) placed horizontally for the first 4 feet along the exposed perimeter of the slab.

Perimeter Length — The linear length of exposed perimeter of the slab.

Polyolefin — A general term for a polymer built from olefins (e.g. polypropylene, polybutylene and polyethylene).

Pressure Loss — The loss of fluid pressure between any two points in a flow-conducting system, expressed in pounds per square inch (psi). The loss of pressure is caused by friction against the tubing walls and is further influenced by the tubing size, length and texture of the inside wall of the tubing, fittings, valves and other components. Pressure loss is also influenced by the temperature and viscosity of the fluid.

Primary/Secondary Pumping — The boiler loop with its own circulator is referred to as the primary loop. Secondary loop is any feed from the primary (boiler loop) that is the same or lower temperature with its own circulator for flow control. Often in snow-melting systems, the secondary flow is first tempered to a lower temperature before entering the secondary loop.

Proportional Valve — A motorized, modulating three-way valve designed to provide consistent supply water temperature based on either outdoor reset temperature or a given setpoint temperature.

R-value — A measure of a material's ability to resist the flow of heat. R-value is expressed in $\text{BTU}/\text{h}/\text{ft}^2$: $(1/U = R)$.

Radiation — The process in which energy in the form of rays of light or heat is transferred from body to body without heating the intermediate air acting as the transfer medium.

Semi-automatic Operation — A snow and ice melting control strategy that operates the system during demand periods and stops operation when there is little or no demand. Semi-automatic operation can be turned on and off manually or automatically under timed situations.

Slab Depth — The thickness of the slab at the perimeter.

Slab on Grade — A concrete slab with a perimeter that is less than 4 feet below the surface.

Surface Temperature — The required temperature at the surface required to melt snow or ice for a given climatic condition based on the $\text{BTU}/\text{h}/\text{ft}^2$ supplied.

Temperature Below — The temperature of the soil below the center of the radiant slab.

Thermal Conductivity (K) — A property of materials that indicates the amount of heat (BTU) that penetrates 1 square foot of a uniform material, 1-inch thick, in one hour for each degree Fahrenheit difference in temperature between the surfaces. It is expressed in $\text{BTU}/\text{h}/\text{ft}^2/^\circ\text{F}$. The thermal conductivity of PEX is $0.22 \text{ BTU}/\text{h}/\text{ft}^2/^\circ\text{F}$.

Thermal Mass — Any material used to store heat energy or the affinity for heat energy.

Total Loop Length — The active loop length added to the leader loop length equals the total loop length.

U-value — The capability of a substance to transfer heat. Used to describe the conductance of a material or composite of materials in construction. U-value is expressed in $\text{BTU}/\text{h}/\text{ft}^2$ and is the inverse function of R-value: $(1/R = U)$.

Under-slab Area — The interior portion of the slab to include all but the first 4 feet around perimeter.

Under-slab Insulation — The amount of insulation (expressed in R-value) under the interior area of the slab, excluding the perimeter area. Under-slab insulation should always be used in snow melting applications to increase efficiency and response times.

Velocity — The speed of fluid at a specific flow expressed in feet per second (fps).

Water Table Temperature — Equal to the estimated temperature of the water table for the area and should be used when the presence of a water table will affect the performance of the radiant panel heating system. Typically, insulation should be added below a radiant slab if there is a water table within 8 to 10 vertical feet of the slab.

Weather Responsive Reset — A method of fine-tuning a radiant system by changing the system supply water temperature based on changing weather conditions. As the outside temperature decreases, the supply water will increase. Likewise, as the outside temperature increases, the supply water temperature will decrease.

Wind Speed — Equal to the highest wind speed at which the system is designed to melt snow and ice. Designs are based on wind speed and outdoor design temperature.



Chapter 2

Introduction

Winter can be an exciting time of year, especially for sport enthusiasts — snowmobiling, sledding, skiing, hockey. But along with the fun comes shoveling, plowing, sanding and salting — as well as the danger of slipping and sliding and the injuries that can result.

Whether for residential, commercial or industrial applications, Uponor Snow and Ice Melting systems provide a safe, reliable and economical alternative to snow removal. Uponor Snow and Ice Melting systems circulate warm fluid through PEX tubing buried in concrete, asphalt or a sand bed. The fluid heats the slab until it is warm enough to melt the snow and ice. The system can be controlled simply with an on/off manual switch or be programmed to function automatically.

Uponor Snow and Ice Melting systems can be used in a variety of applications. These systems are often used in areas where safe, clean and easy access is critical, including:

- Driveways
- Sidewalks
- Stairs
- Building entrances

- Loading docks
- Hospital emergency entrances
- Wheelchair access ramps
- Parking ramps
- Parking lots
- Helipads

Snow and ice melting systems can also help comply with Americans with Disabilities Act (ADA) regulations for safe and easy access.

Convenience is another major factor when considering a snow and ice melting system. Uponor Snow and Ice Melting systems provide:

Safety — Ramps, sidewalks, driveways and steps are free of snow and ice all year long. Accidents are less likely to occur on pavement where snow and ice has not accumulated. Surfaces dry faster and are safer when an Uponor Snow and Ice Melting system is operating underfoot.

Reduced Maintenance — No more shoveling, plowing, sanding or salting. No more replacing sod and landscaping damaged by expensive snow-removal equipment. Additionally, carpets are cleaner

and last longer because snow and salt are not tracked over them.

Increased Pavement Life — Freeze and thaw cycles can be eliminated, extending the life of concrete, asphalt and especially those hard to shovel or plow brick pavers. Additionally, the infrastructure of parking ramps is not damaged by corrosive chemicals used to melt snow and ice.

Energy Savings — Uponor Snow and Ice Melting systems can be designed to take advantage of existing energy sources. For example, facilities often use steam as a primary heat source, which produces condensate. Because these systems typically require only low temperature water, this type of energy or condensate can be captured and used as the heat supply for a snow and ice melting system. The use of waste energy provides a virtually cost-free system operation.



Chapter 3

Uponor Tubing Products and Hardware

PEX is an acronym for crosslinked polyethylene. The PE refers to the raw material used to make PEX (polyethylene), and the “X” refers to the crosslinking of the polyethylene across its molecular chains. The molecular chains are linked into a three-dimensional network that makes PEX remarkably durable within a wide range of temperatures and pressures.

Several methods exist to crosslink polyethylene. These methods produce products with very different properties. Particularly, a distinction should be made between PEX produced above the crystal-melting temperature (hot crosslinking), and PEX produced below the crystal-melting temperature (cold crosslinking).

Uponor manufactures PEX tubing using the Engel method, a hot crosslinking process. The actual crosslinking takes place during the extrusion process when the base polyethylene is above its crystal-melting temperatures. Classified within the industry as PEX-a tubing, Engel-method PEX is superior to other types of PEX produced below the crystal-melting

temperature, which crosslinks after the manufacturing process. Because Uponor PEX tubing incorporates crosslinking during the manufacturing process, the crosslinking is essentially built-in. This results in consistent, uniform and evenly crosslinked PEX, with no weak links within its molecular chains.

PEX Stress Resistance

Tubing installed in snow and ice melting applications must be capable of withstanding the extreme stresses that result from installation within a concrete slab, a sand bed or asphalt.

Typical stresses include:

- Expansion and contraction that result from repeated heating and subsequent cooling of the heat-transfer fluid
- Mechanical abrasion, shearing and stretching that occurs as a result of installation, normal structural movement and heating and cooling from seasonal weather changes

Uponor PEX provides the durability and reliability that’s needed for these applications and currently holds the unofficial world record for long-term

testing at elevated temperature and pressure. Since 1973, the tubing has been subjected to ongoing testing at 203°F/175 psi by Studvik in Sweden and BASF in Germany. The resulting data indicates a life expectancy of well over 100 years. This is critical for a snow and ice melting system that must withstand years of quiet time contrasted with heating seasons that may require a substantial BTU/h output to meet demand during a harsh winter.

PEX Chemical Resistance

Crosslinked polyethylene has greatly enhanced resistance to chemical-dissolving agents. The unique molecular structure is stable and inert and is unaffected by chemicals commonly found in plumbing and heating systems.

Oxygen Diffusion

Oxygen diffusion can cause corrosion problems in a heating system. All non-metallic (plastic or rubber) tubing is permeable to the passage of dissolved oxygen molecules through its walls. Permeability allows these dissolved oxygen molecules to enter an otherwise closed hydronic heating system.

In any new hydronic heating installation, dissolved oxygen molecules exist in the new, fresh water. The large bubbles are purged from the system prior to initial start-up. The dissolved oxygen, however, remains. This dissolved oxygen is not visible in the form of bubbles, and cannot be eliminated by the use of an air vent or scoop.

As the heating system brings the water up to temperature, these dissolved oxygen molecules become more aggressive. They look for ferrous components in the system to attack. The result is corrosion or rust. After a few years of operation, a layer of rust on all ferrous components becomes apparent.

In a typical hydronic system using metallic pipe, almost all dissolved oxygen molecules are used up and cause a non-aggressive rust called “ferrous oxides” usually within the first 72 hours. That’s the end of the corrosion process.

However, in a non-metallic system using plastic or rubber tubing, the corrosion process continues. Nature hates an imbalance. So once all the existing oxygen molecules inside the system are depleted, more dissolved oxygen molecules actually pass through the wall of the tubing to create an equilibrium. When this happens, the corrosion process starts all over again. Left unchecked, this corrosion will continue and cause considerable damage to the ferrous components of the snow and ice melting system.

Damage may include:

- Circulator failures
- Pinhole leaks at expansion tanks
- A red, sludgy build-up inside the system tubing (reducing flow)
- Eventual boiler failure (if a cast-iron or steel boiler is used)

Here are the four ways to manage oxygen diffusion corrosion.

Option 1 — Isolate the heat-transfer fluid from components likely to corrode (e.g., cast-iron pumps, boilers, expansion tanks, etc.) with a non-ferrous heat exchanger. Uponor AquaPEX tubing, without the oxygen diffusion barrier, is available for those systems that isolate the snow-melting loops from the heat plant and circulator components. All other components (e.g., expansion tanks, circulators and piping) on the snow-melting side of the heat exchanger must be made of a non-ferrous material as well.

Option 2 — Eliminate all corrosive ferrous components from the system. Uponor AquaPEX is available for those systems that use non-ferrous components (e.g., bronze pumps, copper tube boilers with bronze headers, etc.).

Option 3 — Treat all heat-transfer fluid with corrosion inhibitors. Corrosion inhibitors require regular maintenance from the heat plant manager to maintain the correct inhibitor level. In the event the system mixture is allowed to lapse, corrosion damage may occur. For these reasons, Uponor does not recommend the use of corrosion inhibitors to counter the effects of oxygen diffusion.

Option 4 — Use tubing that limits the oxygen diffusion into the heat-transfer fluid to a level consistent with established standards. Use Wirsbo hePEX or MLC tubing for these applications.

Selecting an Uponor Tubing Product

Uponor offers three different tubing products for distribution and two products for supply and return mains for use in snow and ice melting installations.

Distribution — Wirsbo hePEX, Uponor AquaPEX and MLC

Supply and Return Mains — Large-dimension Wirsbo hePEX, high-density polyethylene (HDPE)

Note: Wirsbo hePEX and MLC must be used when an oxygen-diffusion barrier tubing is required.

Wirsbo hePEX

Wirsbo hePEX is PEX tubing with an oxygen-diffusion barrier. The tubing is manufactured using the Engel method (PEX-a) of crosslinking.

Application — Wirsbo hePEX is designed for use in closed-loop hydronic snow and ice melting systems operating at sustained temperatures up to 200°F (93.3°C). Corrodible or ferrous components may be used in hot water heating systems designed with Wirsbo hePEX tubing.

Standards, Listings and Ratings

— Wirsbo hePEX is manufactured to meet these standards: ASTM F 876, ASTM F 877 and CAN/CSA B137.5. The Wirsbo hePEX has a Standard Grade Hydrostatic Design Stresses and Pressure Rating in accordance with all three temperatures and pressures listed in Table 1 of ASTM F 876. The Wirsbo hePEX tubing is tested in accordance with PPI TR-3 and listed in PPI TR-4.

The Standard Grade hydrostatic ratings are:

- 200°F (93.3°C) at 80 psi
- 180°F (82.2°C) at 100 psi
- 73.4°F (23°C) at 160 psi

The Hydrostatic Design Stress Board of the Plastics Pipe Institute (PPI) issues these pressure and temperature ratings. These values listed are ratings, not limitations. If the designer stays within these parameters during design, there should not be a problem with the product. Burst pressures are values used only in manufacturing the product, not for the system specification or design.

Wirsbo hePEX is listed with the following agencies.

- Council of America Building Officials (CABO)
One and Two Family Dwelling Code
- ICBO Evaluation Service — ER Number 4407, 5143
- Southern Building Code Congress International (SBCCI) Standard Plumbing Code (PST and ESI Report Number 9661)
- U.S. Department of Housing and Urban Development (HUD)
Material Release Number 1269

Barrier Information — Wirsbo hePEX is sealed with a special polymer barrier to prevent the diffusion of oxygen through the tubing wall and to protect the ferrous components of a closed-loop hydronic snow and ice melting system from corrosion damage. The barrier consists of an EVOH layer co-extruded onto the tubing during the manufacturing process. Uponor applies another thin polyethylene layer over the EVOH barrier on the tubing to reduce possible onsite damage to the oxygen diffusion barrier. This polyethylene layer also provides protection for the EVOH barrier if the tubing is immersed in high moisture applications. The Wirsbo hePEX barrier meets the requirements of the German DIN Standard 4726 for oxygen diffusion prevention. The amount of oxygen that enters the system must be less than 0.10 grams per cubic meter per day at 104°F (40°C).

Linear Expansion Rate —

The unrestrained linear expansion (thermal) rate for Wirsbo hePEX tubing is approximately 1.1 inches per 10°F (5°C) temperature change per 100 feet of tubing.

Dimensions — Wirsbo hePEX is available for snow and ice melting applications in the following tubing sizes and volume:

- 5/8" nominal inside diameter (contains 1.34 gallons/100' of tubing)
- 3/4" nominal inside diameter (contains 1.84 gallons/100' of tubing)
- 1" nominal inside diameter (contains 3.03 gallons/100' of tubing)

Coil Lengths — Please refer to the Uponor Product Catalog for heating products for coil length information.

Uponor MLC Tubing

Uponor MLC tubing is a multi-layered composite tubing consisting of aluminum tubing sandwiched between two layers of PEX. These PEX layers are bonded to the aluminum with a special adhesive.

Application — Uponor MLC is designed for use in closed-loop snow and ice melting heating systems operating at sustained temperatures up to 200°F (93.3°C). Corrodible or ferrous components may be used in hot water heating systems designed with Uponor MLC tubing.

Standards, Listings and Ratings

— Uponor MLC is manufactured to ASTM F 1281 and certified by NSF International. The tubing has a Standard Grade Hydrostatic Pressure Rating in accordance with the temperatures and pressures listed in Section X1 of ASTM F 1281. The tubing is tested in accordance with PPI TR-3 and listed in PPI TR-4. The Standard Grade hydrostatic ratings are:

- 200°F (93.3°C) at 100 psi
- 180°F (82.2 °C) at 125 psi

The Hydrostatic Design Stress Board of PPI issues these pressure and temperature ratings. These values listed are ratings, not limitations. If the designer stays within these parameters during design, there should not be a problem with the product. Burst pressures are values used only in manufacturing the product, not for the system specification or design.

Uponor MLC tubing is listed with the following agencies:

- ICBO Evaluation Service — ER Number 5298
- Southern Building Code Congress International (SBCCI) Standard Plumbing Code (PST and ESI Report Number 9829)

Barrier Information — Uponor MLC tubing offers 100% oxygen-diffusion protection due to the aluminum within the tubing wall.

Linear Expansion Rate —

The unrestrained linear expansion (thermal) rate for MLC tubing is approximately 0.156 inches per 10°F (5°C) temperature change per 100 feet (30.48 meters) of tubing.

Dimensions — Uponor MLC is available for snow and ice melting applications in the following tubing sizes and volume:

- 5/8" nominal inside diameter (contains 1.60 gallons/100' of tubing)
- 3/4" nominal inside diameter (contains 2.56 gallons/100' of tubing)
- 1" nominal inside diameter (contains 4.20 gallons/100' of tubing)

Coil Lengths — Please refer to the Uponor Product Catalog for coil length information.

Uponor AquaPEX

Uponor AquaPEX is a registered trade name for Uponor's hot and cold potable-water tubing. It is essentially the same product as Wirsbo hePEX, but without the oxygen diffusion barrier.

Application — Uponor AquaPEX can be used in closed-loop snow and ice melting systems operating at sustained temperatures up to 200°F (93.3°C), provided any issues concerning oxygen-diffusion are properly addressed. Corrodible or ferrous components may not be used in a system designed with Uponor AquaPEX unless these components are isolated from the tubing.

Standards, Listings and Ratings

— Uponor AquaPEX is manufactured to meet these standards: ASTM F 876, ASTM F 877 and CAN/CSA B137.5. Uponor AquaPEX has a Standard Grade Hydrostatic Design Stresses and Pressure Rating in accordance with all three temperatures and pressures listed in Table 1 of ASTM F 876. Uponor AquaPEX tubing is tested in accordance with PPI TR-3 and listed in PPI TR-4. The Standard Grade hydrostatic ratings are:

- 200°F (93.3°C) at 80 psi
- 180°F (82.2°C) at 100 psi
- 73.4°F (23°C) at 160 psi

The Hydrostatic Design Stress Board of PPI issues these pressure and temperature ratings. These values listed are ratings, not limitations. If the designer stays within these parameters during design, there should not be a problem with the product. Burst pressures are values used only in manufacturing of the product, not for the system specification or design.

Uponor AquaPEX is listed to the following codes, standards and listings.

Codes

IAPMO	UMC
ICC	NSPC
IPC	HUD
IMC	UFGS
IRC	NPC of Canada
UPC	NBC of Canada

Standards

ANSI/NSF 14	263
ANSI/NSF 61	CAN/ULC S101
ASTM F876	ASTM E814/ULC S115
ASTM F877	
ASTM F1960	AWWA C904
ASTM F2023	CSA B137.5
ASTM E84	CSA B214
CAN/ULC S102.2	UL 1821
ASTM E119/UL	ULC/ORD-C199P

Listings

cNSFus-rfh	ETL
cNSFus-pw	PPI TR-4
cQAlus P321	ICC-ES
UL	BMEC
CSA	CCMC

Additional Design Considerations

— Uponor AquaPEX is permeable to oxygen at a rate up to 13.6 grams per cubic meter per day at 158°F (70°C). Snow and ice melting systems using Uponor AquaPEX tubing must be designed to accept oxygen permeation.

Linear Expansion Rate

— The unrestrained linear expansion (thermal) rate for Uponor AquaPEX tubing is approximately 1.1 inches (27.94mm) per 10°F (5°C) temperature change per 100 feet (30.48m) of tubing.

Dimensions — Uponor AquaPEX is available for snow and ice melting applications in the following sizes and volume:

- 5/8" nominal inside diameter* (contains 1.34 gallons/100' of tubing)

- 3/4" nominal inside diameter (contains 1.84 gallons/100' of tubing)
- 1" nominal inside diameter (contains 3.03 gallons/100' of tubing)
- 1 1/4" nominal inside diameter (contains 4.53 gallons/100' of tubing)
- 1 1/2" nominal inside diameter (contains 6.32 gallons/100' of tubing)

Coil Lengths — Please refer to the Uponor Product Catalog for coil length information.

* 5/8" Uponor AquaPEX tubing and fitting information is found only in the Uponor Product Catalog for heating products.

Uponor Large-dimension Wirsbo hePEX Tubing

Uponor large-dimension Wirsbo hePEX tubing is PEX tubing with an oxygen-diffusion barrier. The tubing is manufactured using the Engel method (PEX-a) of crosslinking. This Wirsbo hePEX tubing is metric dimensioned and is not applicable to fitting systems designed for ASTM-dimensioned tubing. Refer to the large-dimension Wirsbo hePEX fitting assemblies shown in the Uponor Product Catalog for additional information.

Application — Uponor large-dimension Wirsbo hePEX tubing is used as supply and return mains in closed-loop hydronic snow and ice melting systems operating at sustained temperatures up to 200°F (93.3°C). Corrodible or ferrous components may be used in hot water heating systems designed with Wirsbo hePEX tubing.

Standards, Listings and Ratings

— Large-dimension Wirsbo hePEX is manufactured in accordance with the German DIN 16893 and tested in accordance with DIN 16892. The tubing has hydrostatic ratings in accordance with the temperatures and pressures listed in **Table 5** of DIN 16893. The hydrostatic ratings are:

- 203°F (95°C) at 87 psi (PB 6 Bar) (maximum intermittent pressure/temperature)
- 194°F (90°C) at 58 psi (4 Bar)
- 140°F (60°C) at 87 psi (6 Bar)

Barrier Information — Large-dimension Wirsbo hePEX is sealed with a special polymer barrier to prevent the diffusion of oxygen through the tubing wall and to protect the ferrous components of a closed-loop hydronic heating system from corrosion damage. The barrier consists of an EVOH layer co-extruded onto the tubing during the manufacturing process. The large-dimension Wirsbo hePEX tubing barrier meets the requirements of the German DIN Standard 4726 for oxygen diffusion prevention. The amount of oxygen that enters the system must be less than 0.10 grams per cubic meter per day at 104°F (40°C). Sustained water temperatures up to 200°F (93.3°C) do not affect the large-dimension Wirsbo hePEX tubing or its oxygen diffusion barrier.

Linear Expansion Rate —

The unrestrained linear expansion (thermal) rate for large dimension Wirsbo hePEX tubing is approximately 1.1 inches per 10°F (5°C) temperature change per 100 feet (30.48m) of tubing.

Dimensions — Uponor large-dimension Wirsbo hePEX tubing is available in the following sizes and volumes.

- 1" nominal inside diameter (contains 3.03 gallons/100' of tubing)
- 1¼" nominal inside diameter (contains 4.53 gallons/100' of tubing)
- 1½" nominal inside diameter (contains 6.32 gallons/100' of tubing)
- 2" nominal inside diameter (contains 10.85 gallons/100' of tubing)
- 2½" nominal inside diameter (contains 16.53 gallons/100' of tubing)
- 3" nominal inside diameter (contains 23.51 gallons/100' of tubing)

Coil Lengths — Please refer to the Uponor Product Catalog for additional information.

Uponor High Density Polyethylene (HDPE) Tubing

Uponor HDPE tubing (PE 3408) is a non-barrier product that is joined by heat-fusion welding. Flange adapters are available to transition to non-ferrous piping. Refer to the Uponor Product Catalog for additional fitting and component information.

Application — Uponor HDPE can be used as supply and return mains in closed-loop hydronic snow and ice melting systems operating at sustained temperatures up to 140°F (60°C), provided any issues concerning oxygen diffusion are properly addressed. Corrodible or ferrous components may not be used in a system designed with Uponor HDPE unless these components are isolated from the tubing.

Standards, Listings and Ratings

— Uponor HDPE tubing and fittings are manufactured by Phillips Driscopipe to meet these standards: ASTM D 3350 and ASTM D 3261. The HDPE tubing has hydrostatic pressure and temperature rating from Plastic Pipe Institute (PPI). The hydrostatic ratings are:

- 140°F (60°C) at 80 psi
- 120°F (48.9°C) at 101 psi
- 100°F (37.8°C) at 125 psi
- 73.4°F (23°C) at 160 psi

Additional Design Considerations

— HDPE tubing has an oxygen-diffusion rate greater than that allowed by the German DIN 4726. Hydronic snow and ice melting systems using HDPE tubing must be designed to accept oxygen permeation or be isolated from ferrous components in the system.

Linear Expansion Rate —

The unrestrained linear expansion (thermal) rate for HDPE tubing is approximately 1.4 inches (35.56mm) per 10°F (5°C) temperature change per 100 feet (30.48m) of tubing.

Dimensions — Uponor HDPE tubing is available in the following sizes and volume:

- 2" nominal inside diameter (contains 15.0 gallons/100' of tubing)
- 3" nominal inside diameter (contains 32.6 gallons/100' of tubing)
- 4" nominal inside diameter (contains 53.87 gallons/100' of tubing)

Tubing Lengths — All sizes listed above are available only in 20-foot lengths. Please refer to the Uponor Product Catalog for additional manifold and fitting information.

Uponor System Components

Uponor offers a complete range of components to complete the snow and ice melting system. **Chapter 7** discusses the control strategies to sense the slab and provide the appropriate fluid temperature to effectively melt the snow from the slab. **Chapter 8** provides the mechanical and electrical schematics for these controls. This section outlines the different manifold sets available for residential and commercial applications.

Uponor TruFLOW™ Manifolds

The TruFLOW™ Classic and TruFLOW Jr. manifolds are the same manifolds used in residential and light commercial heating projects. Both the 1" and 1¼" manifolds are offered with balancing and isolation features.

Balancing — To balance and preset the manifold assembly, proceed as follows.

Step 1 — Using the chrome allen key, turn main valve clockwise until it stops.

Step 2 — Using the small brass key, turn memory stop clockwise until it stops.

Step 3 — Using the chrome allen key, turn the main valve counter-clockwise to set the loop flow or balancing turns for that loop.

Step 4 — Using the small brass key, turn memory stop counter-clockwise until it stops.

Note: Consult the TruFLOW Installation Manual and Balancing Chart to determine the correct number to turns

Applicable Tubing —

TruFLOW manifolds support the following tubing.

- 5/8" Wirsbo hePEX Uponor AquaPEX tubing with ProPEX® or QS20-style fitting assemblies
- 5/8" MLC tubing with QS20-style fitting assemblies

HDPE Valveless Manifolds

The HDPE manifolds are available in 2, 3 and 4-inch dimensions. The manifolds have 300-series stainless steel ProPEX fitting adapters preformed on the HDPE outlets. The manifold is designed to only support ¾" and 1" PEX tubing. The HDPE manifolds do not have an oxygen diffusion barrier. Primary application is for direct burial in systems isolated with a heat exchanger. Refer to **page 16** for the exploded HDPE manifold view.

Balancing — These manifolds are not designed to balance across the manifold. All loop lengths must be within 3% of each other in length on the manifold.

Example

If the design calls for 267-foot loops on the manifold, then the range of loop lengths must fall within 263 and 271 feet. Three percent of 267 feet is 8 feet — 4 feet either side of your target length.

Supply and return piping to the manifold should be installed in a reverse-return configuration to allow self-balancing across the manifold.

Applicable Tubing — These HDPE manifolds support the following tubing.

- ¾" and 1" Wirsbo hePEX and Uponor AquaPEX tubing with ProPEX fitting assemblies

Copper Valved Manifolds

These 2-inch copper valved manifolds are 48 inches long with 12 valved outlets. The outlets come in several configurations of ProPEX or male threaded connections. The outlets are valved with either a ball valve (isolation) or a ball valve /balancing valve combination (isolation with balancing). Refer to **pages 17** and **18** for detailed information about the options available with this manifold.

Balancing — Remove the knurled safety cap from the valve. Using an Allen or hex key, turn the memory spindle clockwise until closed. To balance, turn the hex key (counter clockwise) the number of required turns from close. Replace the safety cap. The longest loop on the manifold will be left full open. From closed to full open is 10 full turns of the memory spindle. Balance the other loops using the formula shown below.

Loop to be balanced / longest loop on the manifold x 10 = number of turns from closed

Example

Loop to be balanced: 250 feet

Longest loop on the manifold: 300 feet

$$x = 250 / 300 \times 10$$

$$x = 0.83 \times 10$$

$$x = 8.3$$

The memory spindle for that 250-foot loop would be turned open 8.3 turns from closed.

Applicable Tubing — These copper valved manifolds support the following tubing.

- 5/8" and ¾" Wirsbo hePEX and Uponor AquaPEX tubing with ProPEX or QS20-style fitting assemblies
- 5/8" and ¾" MLC tubing with QS20-style fitting assemblies

TruFLOW™ Classic and Jr. Heating Manifold Exploded View

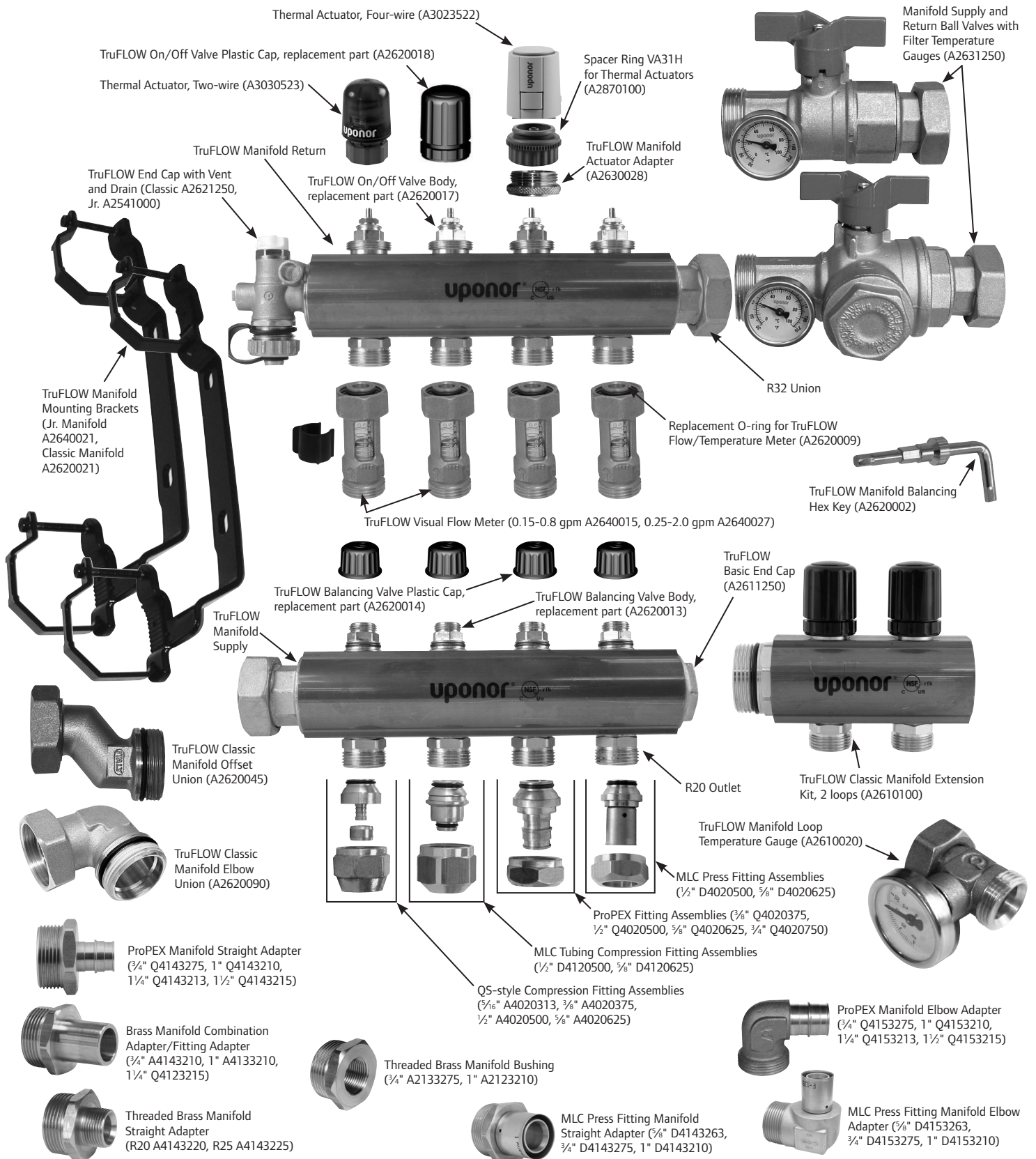

Exploded HDPE Manifold View

2" HDPE Manifold with ¾" PEX

1. 2" HDPE End Cap (B2202000)
2. 2" HDPE ProPEX Manifold - 10 outlet (B2252751)
- 20 outlet (B2252752)
3. ¾" Stainless Steel ProPEX Fittings (performed on outlet)
4. ¾" ProPEX Rings (Q4680750)
5. ¾" Uponor AquaPEX Tubing (F1100750)

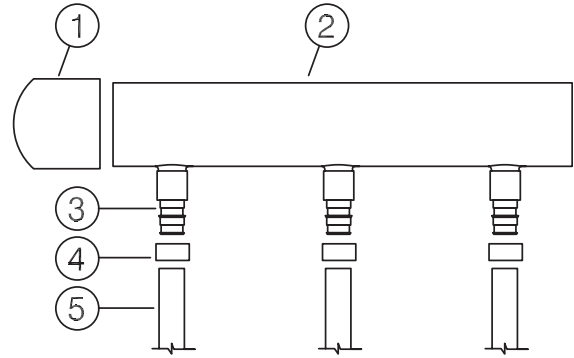

3" HDPE Manifold with ¾" PEX

6. 3" HDPE End Cap (B2203000)
7. 3" HDPE ProPEX Manifold - 10 outlet (B2253751)
- 20 outlet (B2253752)
8. ¾" Stainless Steel ProPEX Fittings (performed on outlet)
9. ¾" ProPEX Rings (Q4680750)
10. ¾" Uponor AquaPEX Tubing (F1100750)

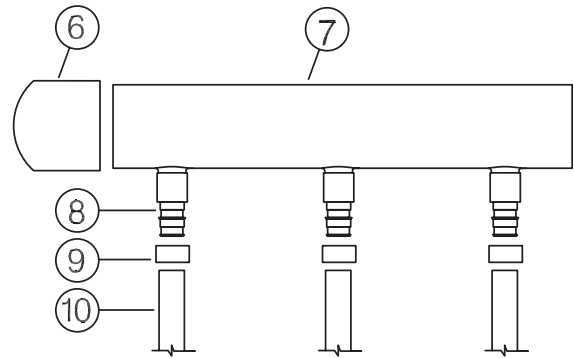

4" HDPE Manifold with ¾" PEX

11. 4" HDPE End Cap (B2204000)
12. 3" HDPE ProPEX Manifold - 10 outlet (B2254751)
- 20 outlet (B2254752)
13. ¾" Stainless Steel ProPEX Fittings (performed on outlet)
14. ¾" ProPEX Rings (Q4680750)
15. ¾" AquaPEX Tubing (F1100750)

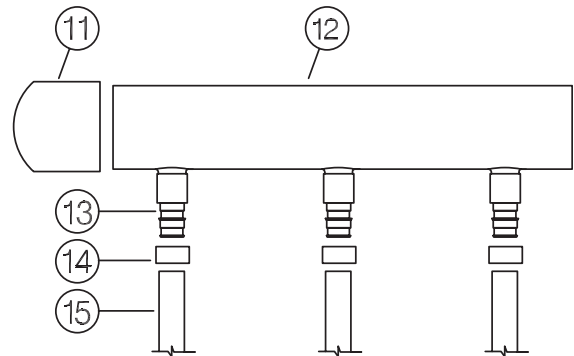

2" HDPE Manifold with 1" PEX

1. 2" HDPE End Cap (B2202000)
2. 2" HDPE ProPEX Manifold - 10 outlet (B2272101)
- 20 outlet (B2272102)
3. 1" Stainless Steel ProPEX Fittings (performed on outlet)
4. 1" ProPEX Rings (Q4681000)
5. 1" Uponor AquaPEX Tubing (F1061000)

3" HDPE Manifold with 1" PEX

6. 3" HDPE End Cap (B2203000)
7. 3" HDPE ProPEX Manifold - 10 outlet (B2273101)
- 20 outlet (B2273102)
8. 1" Stainless Steel ProPEX Fittings (performed on outlet)
9. 1" ProPEX Rings (Q4681000)
10. 1" Uponor AquaPEX Tubing (F1061000)

4" HDPE Manifold with 1" PEX

11. 4" HDPE End Cap (B2204000)
12. 4" HDPE ProPEX Manifold - 10 outlet (B2274101)
- 20 outlet (B2274102)
13. 1" Stainless Steel ProPEX Fittings (performed on outlet)
14. 1" ProPEX Rings (Q4681000)
15. 1" Uponor AquaPEX Tubing (F1061000)

2" Copper Valved Manifolds

The 2" Copper Valved Manifold comes with 12 3/4-inch ports that are installed at 4 inches on center. The manifold is 48 inches long. The manifold comes with a series of options for valving.

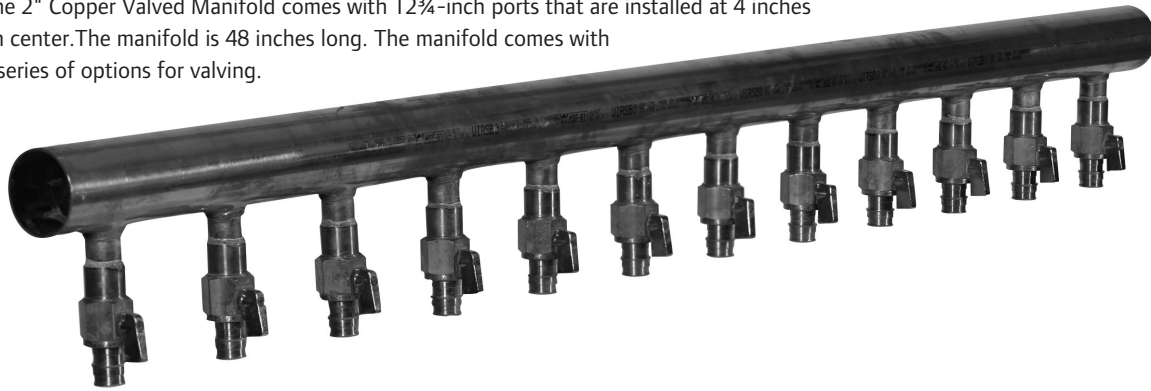

Option 1

The 2" Copper Valved Manifold is available for 5/8" and 3/4" ProPEX fitting adapters with an isolation ball valve. This ball valve is used only for isolation and not balancing.



Part Number	Description
Q2811263	2" CU Manifold with 5/8" ProPEX Ball Valve, 12 branches
Q2811275	2" CU Manifold with 3/4" ProPEX Ball Valve, 12 branches

Option 2

The 2" Copper Valved Manifold is available for 5/8" and 3/4" ProPEX fitting adapters with an isolation ball valve and an in-line balancing valve. This manifold can be used for isolation and balancing.

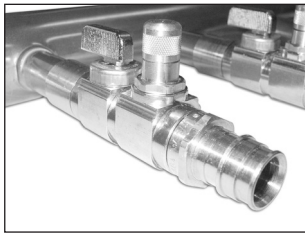

Part Number	Description
Q2821263	2" CU Manifold with 5/8" ProPEX Balancing/Ball Valve, 12 branches
Q2821275	2" CU Manifold with 3/4" ProPEX Balancing/Ball Valve, 12 branches

Option 3

The 2" Copper Valved Manifold is available with either a 5/8" tubing to R20 threaded fitting adapter or with a 3/4" tubing to R25 threaded fitting adapter. Both fittings come with an isolation ball valve. This ball valve is used only for isolation and not balancing. Tubing fitting assemblies are purchased separately.



Part Number	Description
F2811220	2" CU Manifold with R20 Ball Valve, 12 branches
F2811225	2" CU Manifold with R25 Ball Valve, 12 branches

Option 4

The 2" Copper Valved Manifold is available with either a 5/8" tubing to R20 threaded fitting adapter or with a 3/4" tubing to R25 threaded fitting adapter. Both fittings come with an isolation ball valve and an in-line balancing valve. This manifold can be used for isolation and balancing. Tubing fitting assemblies are purchased separately..

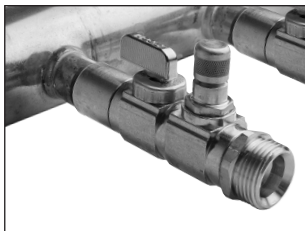

Part Number	Description
F2821220	2" CU Manifold with R20 Balancing/Ball Valve, 12 branches
F2821225	2" CU Manifold with R25 Balancing/Ball Valve, 12 branches

Chapter 4

Installation Methods



The first step in designing a snow and ice melting system is to listen closely to customers' needs. This helps identify how the system should be designed. Uponor Snow and Ice Melting systems can be installed in a variety of construction methods. The type of construction method used impacts the control strategy. The extent of snow and ice melting required determines the heat load, the on-center distance of the tubing and the placement of insulation around the slab.

The most common installation methods are:

- Concrete slab
- Two-lift asphalt pours
- Compactable soil/sand bed covered by concrete, asphalt or pavers
- Concrete overpour
- Suspended (bridges)
- Stairs

Compaction

Prior to installing any tubing, a solid foundation must be present to ensure the snow-melting system does not shift or settle. (Compaction is required for any slab, sidewalk, driveway, road, etc.) Typical compaction rates are 96 to 98% for soil, and around 101 to 103% for a compactable soil/sand base as stated by ASTM. A qualified materials testing agency should test the compaction rates.

It is also recommended that you consult local code officials regarding the requirements for the area where the system will be installed. If insulation is required for the snow-melt installation, use an insulation board or material with an under-slab compressive strength rating. To determine the proper compressive strength board or material, review the installation to assess "live" and "dead" load conditions.

Live Loads — People or objects moving across the snow-melt area and the weight associated with them, e.g., people, cars, trucks, utility vehicles, aircraft, etc.

Dead Loads — Fixed or permanent objects and the weight associated with them.

Uponor recommends that an architect or engineer review the requirements and materials (if not specified) prior to installation. Improper compaction and insulation materials that do not carry ratings can result in the insulation materials collapsing due to any applied weight.

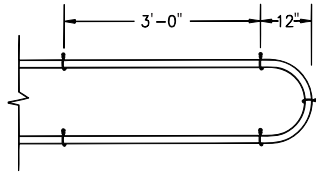

Figure 4-1: Tubing Installed with Wire Ties

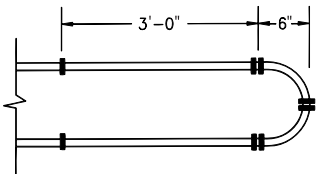

Figure 4-2: Tubing Installed with Foam Staples

Installation

To begin the tubing installation, place wire mesh or rebar over the compacted grade. Using Uponor wire ties, secure the tubing to the wire mesh or rebar. Place wire ties approximately every 3 feet along straight runs. At the 180-degree turns, tie the tubing at the top of the arc and once on each side, 12 inches from the top of the arc (see **Figure 4-1**). This prevents the tubing from dislodging and/or floating up during the pour.

When installing PEX tubing over the appropriate strength high-density insulation board, secure

the tubing to the insulation board with Uponor plastic foam staples using the manual stapler. Place the foam staples approximately every 3 feet along straight runs. At the 180-degree turns, staple the tubing twice at the top of the arc and on each side, 6 inches from the top of the arc (see **Figure 4-2**).

Minimum concrete covering for the tubing is detailed in local building codes. Generally, a minimum of 1½ inches of concrete must be over the top of the tubing when the slab is exposed to earth or weather conditions (1997 UBC Sec. 1906.3.10).

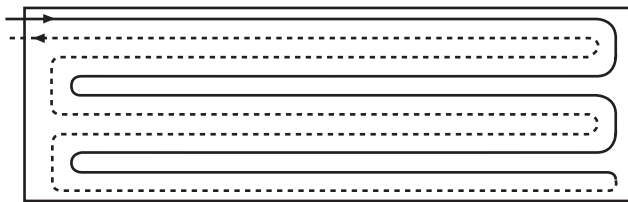

Figure 4-3: Reverse-return Layout



Figure 4-4: Serpentine Layout

Tubing Layout Patterns

The most common layout pattern for snow and ice melting applications is counter flow or reverse return, which allows equal heat across the surface. This is different from radiant floor heating applications where tubing is installed with the supply or warmest water going first to the area of the greatest heat loss — the exterior wall.

Reverse-return Layout — The reverse-return tubing layout allows the entire snow and ice melting surface to heat up equally. Install the tubing as shown in **Figure 4-3** with the supply and return portion of the tubing running parallel to each other.

Serpentine Layout — The serpentine tubing layout is not as effective in a snow and ice melting application since too great of a surface temperature differential would be experienced across the area (see **Figure 4-4**).

Insulation

Load requirements (BTU/h/ft²) for snow and ice melting applications are significantly higher than what is required for radiant floor heating applications. Therefore, insulation plays a much more important role from the standpoint of performance, efficiency and control.

Performance — The system reacts more quickly to changing climatic conditions when proper insulation is installed. The performance charts in **Appendix C** are calculated with

2-inch high-density insulation or an equivalent R-value of 10 under the slab.

Efficiency — Insulation prevents wasted energy by keeping heat confined to areas that are part of the snow-melting scope, both laterally and vertically downward.

Control — A properly insulated slab allows for a wider variety of control schemes. For example, a semi-automatic control strategy is not recommended for an un-insulated slab.

Heat loss is critical to the performance of any snow and ice melting design and needs to be accounted for in the planning stages. There are two areas to keep in mind when insulating a snow and ice melting application — horizontal/under slab and vertical/edge.

Horizontal or Under Slab — This is the area or layer directly beneath the tubing. Essentially, this insulation layer is the difference between a high and low mass system. From radiant floor heating applications, we've

learned how under-slab insulation can affect start-up times or react to radical changes in weather so the use of Under Slab Insulation is highly recommended. When the slab is outside, the performance of the snow melt area can be affected when the following conditions exist and no Under Slab insulation is installed:

- High water tables and/or moist soil conditions are present
- The system is designed for semi-automatic operation
- The linear feet of perimeter is high in relation to the snow-melted area (e.g., sidewalk)

Vertical or Edge — This area denotes the vertical edge of the slab or profile. Edge insulation is used to keep the heat contained within the area for which it is designed and to minimize lateral heat loss. When using edge insulation remember the following.

- Insulate along edges that come into contact with plants or landscaping. If the plants sense warmth, they may be fooled into thinking spring has arrived. This can have a negative effect and ultimately kill any plants, shrubs or grass.
- Insulate down to the frost line (or suitable depth) when under-slab insulation is not installed. Protecting the edge of the slab will only allow for heat to be lost under the bottom edge of the insulation. Insulating in this manner is marginally better than no edge insulation at all.

Construction, Expansion and Control Joints

Construction, expansion and control joints are requirements for every slab application of any size. Coordination between the engineer, concrete installer and the snow-melting contractor is essential to avoid confusion and delays on the project.

Construction Joints — Joints that separate two separate pours of a slab completed at different times are called construction joints. Because it is difficult to construct a large slab in one pour, a bulkhead is installed to contain sections of the slab until the next phase is poured. That makes it easier to move concrete equipment, and reduces the chances that the tubing will be damaged during installation.

Avoiding the Construction Joint — To avoid the construction joint during installation, dip the tubing below the slab into the subsoil (see **Figure 4-5**).

Expansion Joints — Sometimes called isolation joints, expansion joints are intended to absorb horizontal movement caused by the thermal expansion and contraction of the slab. Snow and ice melting systems can reduce the range of expansion the slab experiences depending on the control strategy selected.

The coefficient of linear expansion for concrete is approximately 5.5×10^{-6} inch per degree Fahrenheit. This means, roughly, that for every 1°F (0.5°C) temperature rise, a 100-foot span of concrete is expected to expand about 1/16 of an inch.

Penetrating the Expansion Joint — If the tubing must penetrate the fibrous expansion joint, wrap it with pipe insulation for 6 inches on both sides of the expansion joint (see **Figure 4-6**).

Avoiding the Expansion Joint — Dip the tubing below the slab into the subsoil (see **Figure 4-7**).

When foam insulation is used to sleeve PEX running through an expansion joint and/or to accommodate minor shear action, minimum cover should be determined by the wall thickness of the insulation. For example, if the insulation used is to accommodate 3/8 of an inch of vertical shear, select

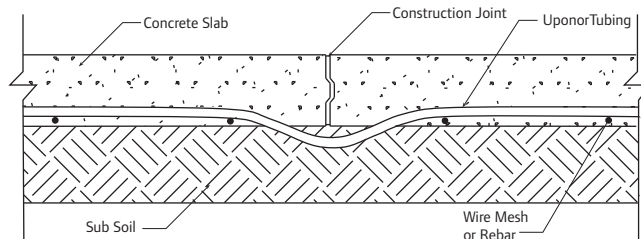

Figure 4-5: Avoiding Construction Joint

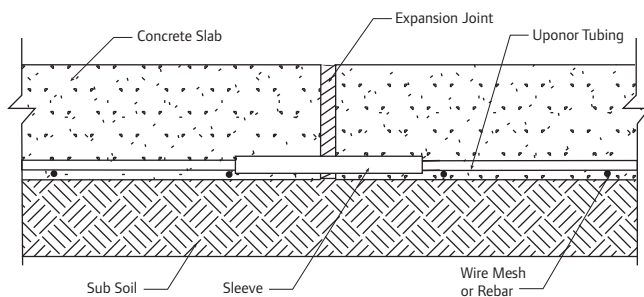

Figure 4-6: Penetrating the Expansion Joint

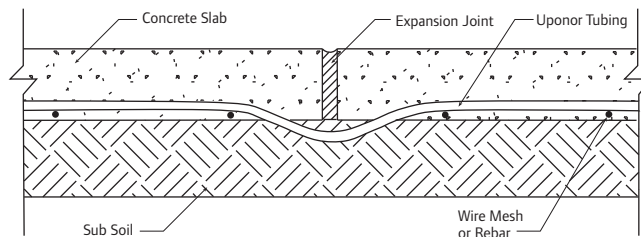

Figure 4-7: Avoiding Expansion Joint

pipe insulation with a minimum wall thickness 3/8 of an inch.

Control Joints — Control joints allow the concrete to fracture along a controlled line. There is no concern for the tubing penetrating beneath a cut joint during the cracking phase of the concrete. The concern for the tubing is during the phase in which the concrete is initially cut. Depending on the depth of the concrete, the control joint may penetrate from 1/2 inch to depths greater than 1 inch.

Installation for Control Joints

— Ensure that the tubing is secured from the reach of the saw blade and cannot be harmed. It is recommended to secure the tubing 6 inches on each side of the control joint. It is important to mark where the joint can be made after the pour (see **Figure 4-8**).

Note: When designing a snow and ice melting system, avoid passing the tubing through or below construction, expansion and control joints whenever possible. Coordinate the placement of these joints prior to designing the tubing layout.

Pressurizing

Once the tubing installation is complete with connections to the manifold, pressure test it to a minimum of 60 psi for at least 24 hours (or to local code requirement) to ensure system integrity. It should also remain under pressure during the concrete pour. Pressurize the system with air. If water is used, you must drain the system after the pour in order to prevent a freeze. Water is not recommended when weather is close to freezing since it is nearly impossible to totally drain the system.

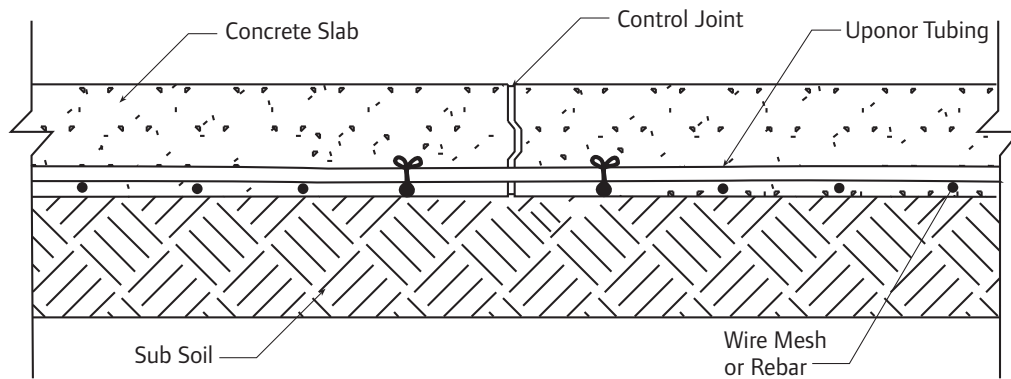

Figure 4-8: Installation for Control Joints

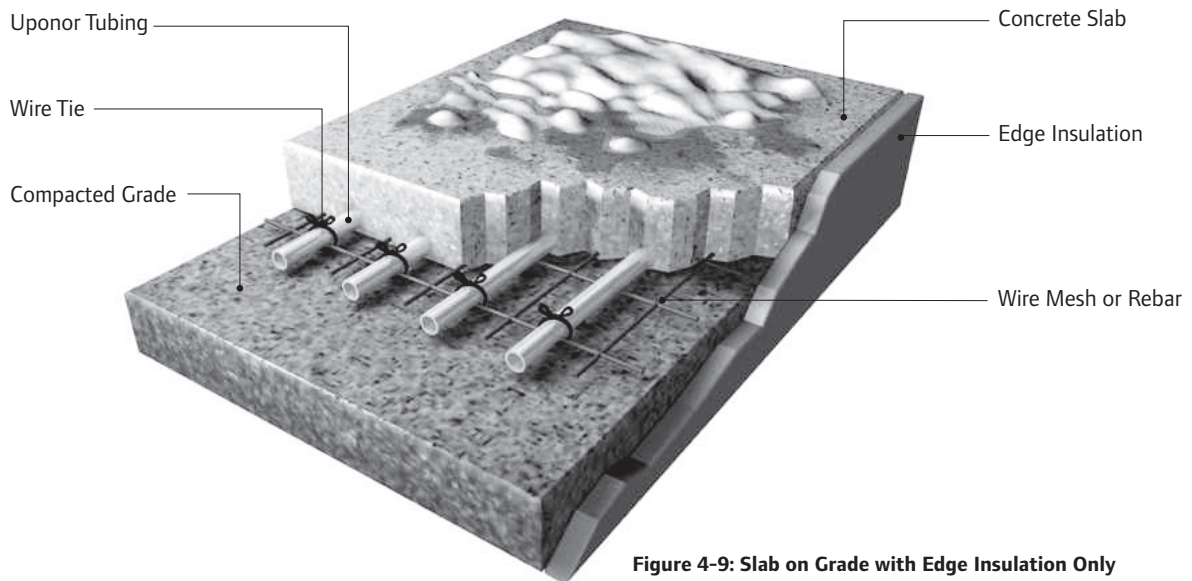

Figure 4-9: Slab on Grade with Edge Insulation Only

Slab on Grade with Edge Insulation Only

Application

This method is for designs with heavy vertical load requirements or cost constraints preventing insulation of the entire slab. With only edge insulation, the heated soil beneath the slab acts as a heat sink storing energy and later supports the slab during a sudden air temperature drop requiring additional heat. Response time is quite slow.

Where Used

This installation is applicable for the following applications.

- Roads
- Emergency accesses
- Helipads
- Loading docks

How to Install

The base layer must be properly compacted prior to installing any tubing. Place wire mesh or rebar over the compacted base material. As shown in **Figure 4-9** above, secure the tubing to the mesh with wire ties or other suitable attachment method. Install vertical insulation along the entire

perimeter. It is recommended to install horizontal insulation within the first 4 feet of the slab's perimeter.

What to Look For

- Make sure the base material is properly compacted as specified by the project engineer.
- Be aware that this type of installation will create a heat sink below, and must be factored into the control strategy.
- If a high water table or moist soil conditions are within 8 to 10 vertical feet of the slab, do not use this method.
- Cover the top of the tubing with a minimum of 1½ inches of concrete.

Control Strategy

Use the constant idle or automatic strategy with a minimum idle setpoint temperature above freezing.

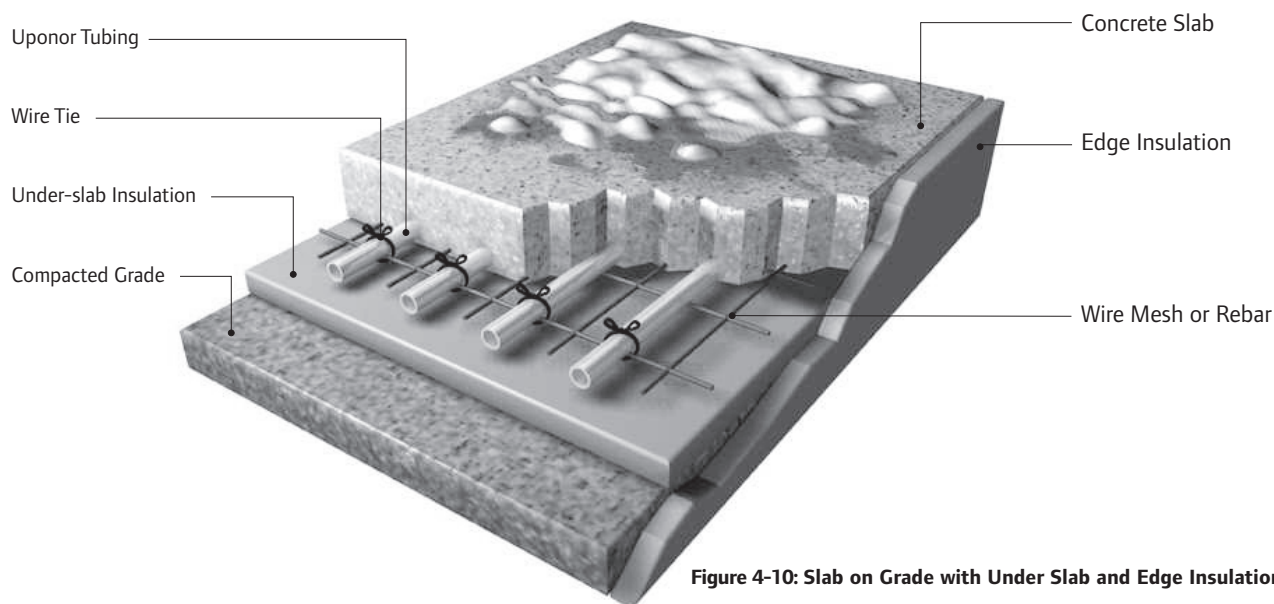

Figure 4-10: Slab on Grade with Under Slab and Edge Insulation

Slab on Grade with Under Slab and Edge Insulation

Application

This method is for designs with light to moderate vertical load requirements across the slab. With under slab and edge insulation, the heated slab is isolated from high movement of energy from the slab to the surrounding frozen soil. Response time is fairly quick and even faster if the slab is idled.

Where Used

This installation is applicable for the following applications.

- Sidewalks
- Driveways
- Helipads

How to Install

The base layer must be properly compacted prior to installing the insulation and tubing. There are two ways to install the tubing over the high-density insulation. As shown in **Figure 4-10** above, secure the tubing to the wire mesh or rebar which has been placed over the high-density insulation board. With the other method, secure the tubing

to the high-density insulation using Uponor plastic staples with the manual stapler.

Install vertical insulation along the entire edge down to the depth of the horizontal under-slab insulation. The insulation creates a thermal break between the heated slab and the frozen ground.

What to Look For

- Make sure the base material is properly compacted as specified by the project engineer.
- Verify whether a high water table or moist soil conditions exist within 8 to 10 vertical feet of the slab. If found, isolate the slab from the moisture.
- Using approved under-slab insulation with vertical compressive strength is critical. Consult with the insulation manufacturer or project engineer for recommendations.
- Cover the top of the tubing with a minimum of 1½ inches of concrete.

Control Strategy

Use the semi- or fully automatic strategy for this installation method.

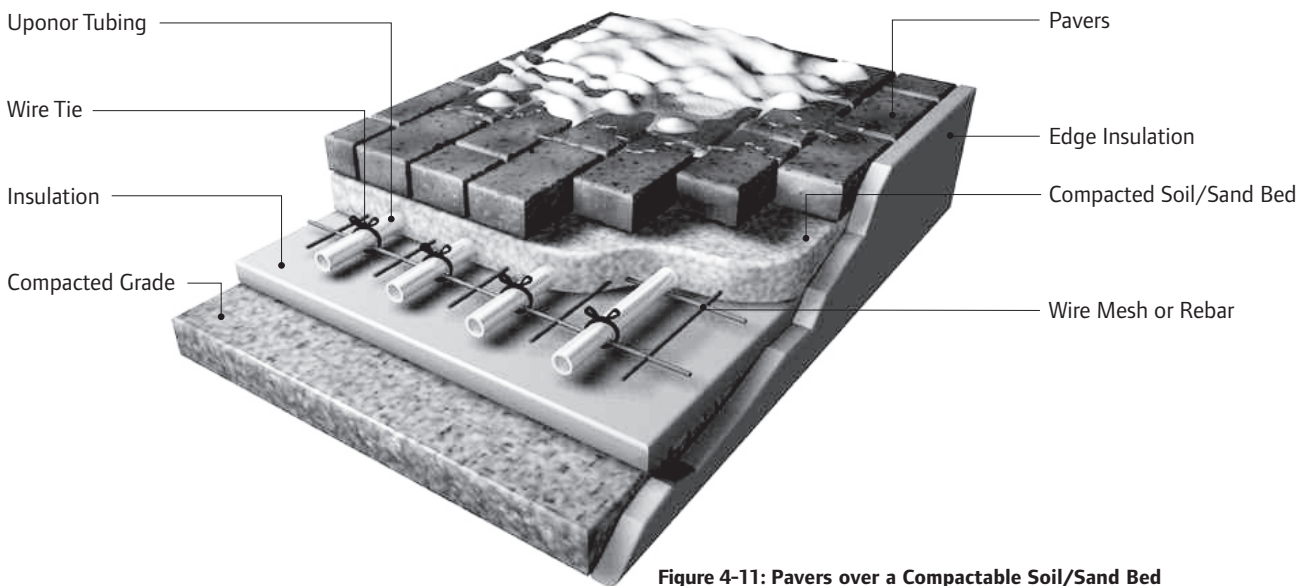

Figure 4-11: Pavers over a Compactable Soil/Sand Bed

Pavers over a Compactable Soil/Sand Bed

Application

This method is for designs with light vertical load requirements. With insulation, the heated area is isolated from high movement of energy from the system to the surrounding frozen soil. Response time is fairly quick and even faster if the system is idled.

Where Used

This installation is applicable to the following applications.

- Sidewalks
- Driveways
- Low-density roads

How to Install

There are two ways to install the tubing over the high-density insulation. As shown in **Figure 4-11**, secure the tubing to the wire mesh or rebar which has been placed over the high-density insulation board. In the alternative method, secure the tubing to the high-density insulation using Uponor plastic staples with the manual stapler.

Install vertical insulation along the entire edge down to the depth of the horizontal insulation. The insulation creates a thermal break between the heated area and the frozen ground.

After installing the tubing, cover with a compactable soil/sand bed (typically 2 to 3 inches) prior to applying pavers or bricks.

What to Look For

- Make sure the base material is properly compacted as specified by the project engineer.
- Verify whether a high water table or moist soil conditions exist within 8 to 10 vertical feet of the snow and ice melting system. If found, isolate the system from the moisture.
- Using approved insulation with vertical compressive strength is critical. Consult with the insulation manufacturer or project engineer for recommendations.
- Supply water temperatures for this application should be no higher than 150°F (65.56°C).

Control Strategy

Use the semi- or fully automatic strategy for this installation method.

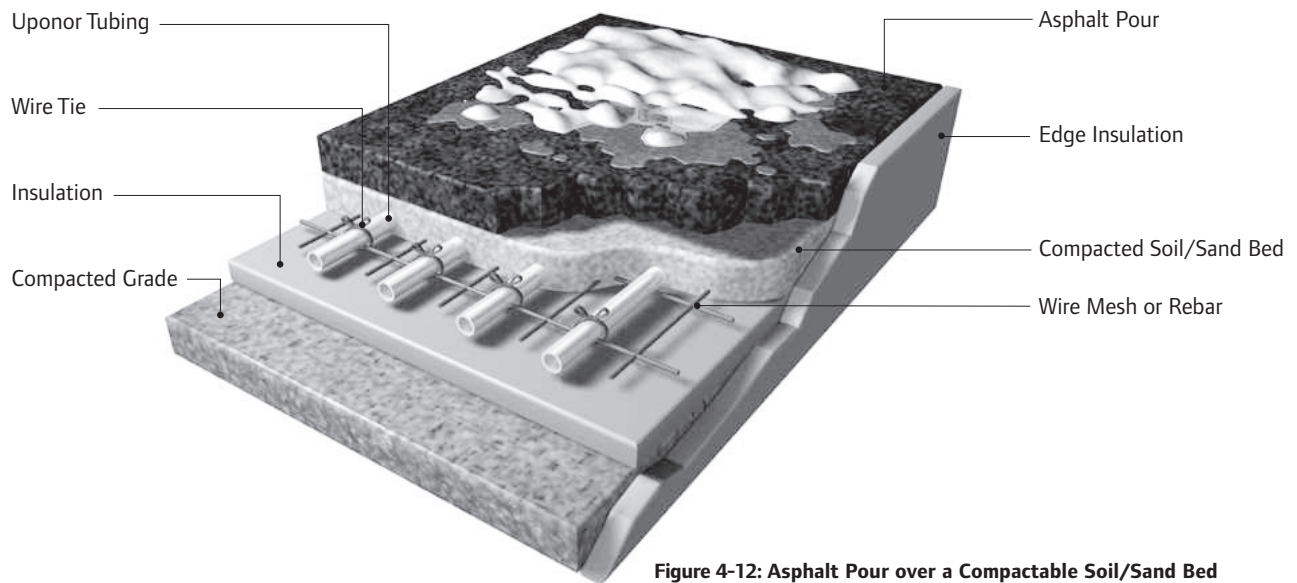

Figure 4-12: Asphalt Pour over a Compactable Soil/Sand Bed

Asphalt Pour over a Compactable Soil/Sand Bed

Application

This method is for designs with light vertical load requirements. With insulation, the heated area is isolated from high movement of energy from the snow and melting system to the surrounding frozen soil. Response time is fairly quick and even faster if the system is idled.

Where Used

This installation is applicable to the following applications.

- Sidewalks
- Driveways
- Low-density roads

How to Install

There are two ways to install the tubing over the high-density insulation. As shown in **Figure 4-12**, secure the tubing to the wire mesh or rebar which has been placed over the high-density insulation board. With the alternative method, secure the tubing to the high-density insulation using Uponor plastic staples with the manual stapler.

Install vertical insulation along the entire edge down to the depth of the horizontal insulation. The insulation creates a thermal break between the heated area and the frozen ground.

After installing the tubing, cover with a compactable soil/sand bed (typically 3 inches) prior to applying the asphalt pour.

What to Look For

- Make sure the base material is properly compacted as specified by the project engineer.
- Ensure the soil/sand bed over the tubing can be compacted to a level acceptable for the asphalt installer.
- Verify whether a high water table or moist soil conditions exist within 8 to 10 vertical feet of the snow and ice melting system. If found, isolate the system from the moisture.

- Using approved insulation with vertical compressive strength is critical. Consult with the insulation manufacturer or project engineer for recommendations.
- Supply water temperatures for this application should be no higher than 150°F (65.56°C).

Control Strategy

Use the semi- or fully automatic strategy for this method.

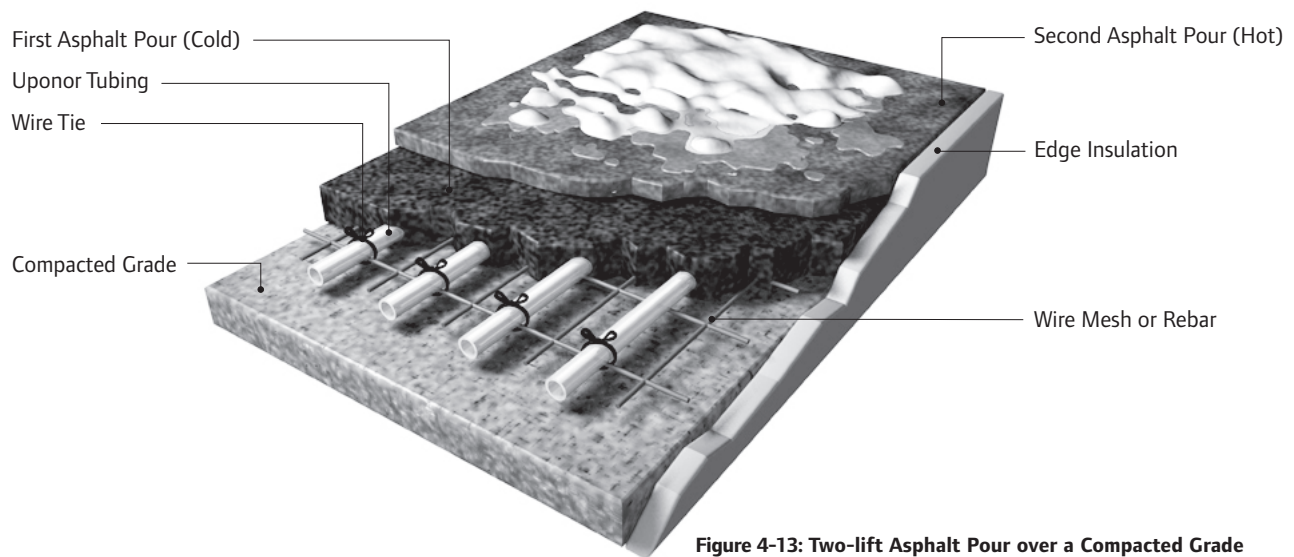

Figure 4-13: Two-lift Asphalt Pour over a Compacted Grade

Two-lift Asphalt Pour over a Compacted Grade

Application

This method is for designs with heavy vertical load. It's used only when the asphalt installer requires the higher level of compaction in order to move the paving machine up a slope, or if the application will operate above freezing throughout the heating season. The heated soil beneath the system acts as a heat sink storing energy, and later supports the system during a sudden drop in air temperature that requires additional heat.

Where Used

This installation is applicable to the following applications.

- Steep driveways
- High-density roads
- Emergency accesses

How to Install

Without insulation, place wire mesh or rebar over the compacted base material. Secure tubing to the mesh with wire ties or other suitable attachment method.

As shown in **Figure 4-13**, install vertical insulation along the entire edge. It is recommended to install horizontally insulation within the first 4 feet of the slab's perimeter. The insulation creates thermal breaks between the heated area and the frozen ground.

Carefully place the asphalt over the tubing and rake it level before compacting. Do not use an asphalt machine to lay the first lift of asphalt.

If the asphalt temperature exceeds 180°F (82.22°C), the PEX tubing must be cooled during the lift to prevent damage to the tubing. Connect the tubing or manifold(s) to a fresh water source and continuously run cold water through the tubing to dissipate the heat. The water drains from the return manifold creating an open system.

Note: The temperature of the asphalt poured directly over the tubing must never exceed 240°F (115.56°C).

What to Look For

- Make sure the base material is properly compacted as specified by the project engineer.
- Make sure the PEX is properly cooled during a high-temperature [greater than 180°F (82.22°C)] lift.

Control Strategy

Use constant idle or automatic strategy with a minimum idle setpoint temperature above freezing.

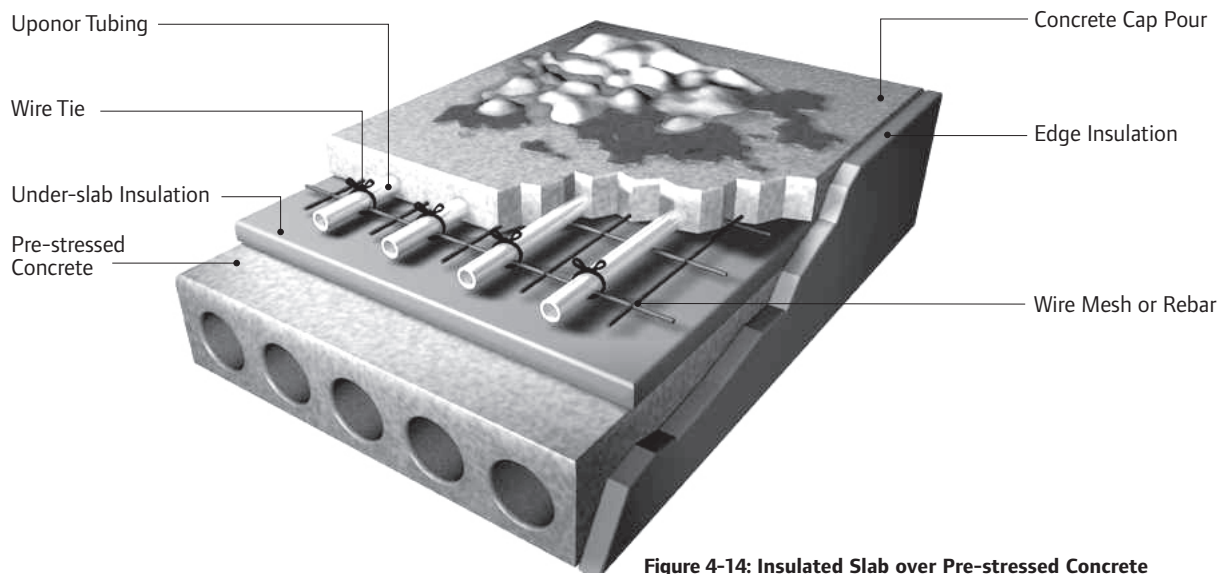

Figure 4-14: Insulated Slab over Pre-stressed Concrete

Insulated Slab over Pre-stressed Concrete

Application

This is a commercial installation. It is critical to make an effective thermal break between the heated slab and the structural slab below. Otherwise, the rate of heat migration into the structural slab will result in a loss of control over the snow-melt system.

Where Used

This installation is applicable to the following applications.

- Parking ramps
- Suspended ramps

How to Install

There are two ways to install the tubing over the high-density insulation. As shown in **Figure 4-14**, secure the tubing to flat wire mesh or rebar which has been placed over the high-density insulation board.

With the alternative method, secure the tubing to the high-density insulation using Uponor plastic staples with the manual stapler. Plastic foam staples must be the proper length to avoid penetrating

completely through the insulation. If the staple is too long and the staple does not seat properly, it may allow the tubing to slide loosely inside the staple.

Install vertical insulation along the entire edge down to the depth of the horizontal under-slab insulation. The use of insulation creates a thermal break between the heated slab and the unheated structural slab.

What to Look For

- Using approved under-slab insulation with vertical compressive strength is critical. Consult with the insulation manufacturer or project engineer for recommendations.
- Ensure a minimum of 1½ inches of concrete is over the top of the tubing.
- Place staples or wire ties no more than 2 to 3 feet apart in the cap pour to eliminate floating.

Control Strategy

Use the automatic strategy with an idle setpoint temperature above freezing.

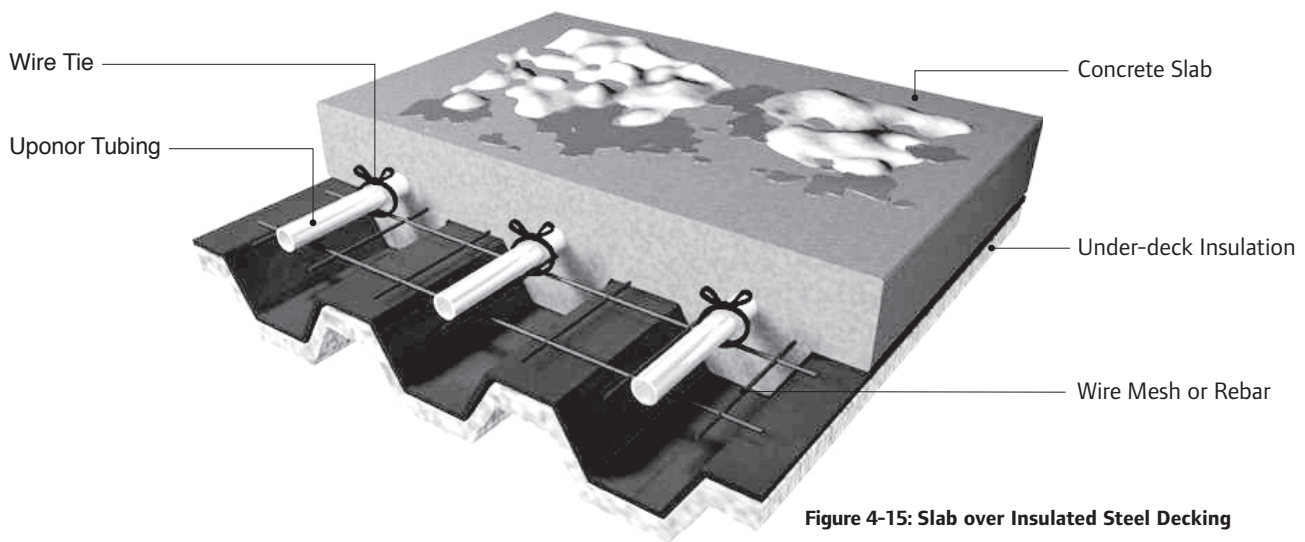

Figure 4-15: Slab over Insulated Steel Decking

Slab over Insulated Steel Decking

Application

This is a commercial installation. The insulation under the decking is usually sprayed on after construction. It is critical that the resistance value (R-value) of the insulation meets or exceeds the requirement specified in the snow-melt design.

In suspended installations, the effect of wind must be considered in the design. Suspended installations require greater amounts of insulation to overcome the impact of moving air. The insulation should be covered to reduce the wind effect. Additionally, some spray-on insulation is vulnerable to ultraviolet (UV) degradation.

Where Used

This installation is applicable to the following applications.

- Bridges
- Suspended ramps

How to Install

As shown in **Figure 4-15**, secure the tubing to flat mesh or to chaired rebar. Install the tubing within 3 to 4 inches from the surface of the snow-melt slab.

Install the vertical insulation along the entire edge down to the depth of the horizontal under-slab insulation. The insulation creates a thermal break between the heated slab and the surrounding unheated structural.

What to Look For

- Protect the insulation from site abuse and any possible UV degradation, if applicable.
- Consult with the insulation manufacturer or project engineer for recommendations.
- Ensure a minimum of 1½ inches of concrete is over the top of the tubing.
- Place wire ties no more than 2 to 3 feet apart in the cap pour to eliminate floating.

Control Strategy

Use the automatic strategy with an idle setpoint temperature above freezing.

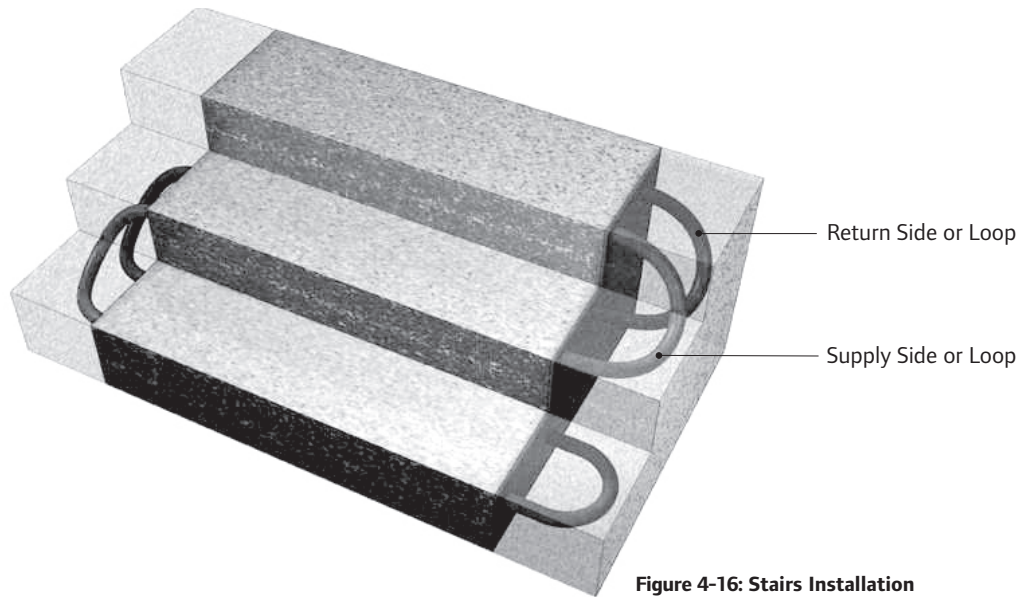

Figure 4-16: Stairs Installation

Stairs Installation

Application

Stairs can be very hazardous during the winter. They are also the most expensive and time-consuming area for manual snow and ice removal.

Where Used

This installation is applicable to the following applications.

- Public access areas
- Location where hazardous conditions develop quickly (e.g., north-facing installations)
- Where economic alternative methods are required over conventional snow removal

How to Install

The most critical portion of the step is the leading edge formed by the tread and the step riser. This area has the greatest exposure to air temperature and wind effect with the least heated mass to counter these effects.

As shown in **Figure 4-16**, install the tubing parallel to the edge of the step tread. Run supply on the leading edge of the treads. Secure

the tubing to the reinforcing bar within the stair structure. Tubing bend supports can assist the install in making the required tight turns.

What to Look For

- Use vertical insulation where it can minimize lateral heat loss and wind effect.
- Install tubing a minimum of 6 inches on center to maximize coverage on stair tread.
- Lay the tubing loop from the top tread down to the bottom tread. This helps eliminate unwanted air traps from developing in the loop.

Control Strategy

Use the constant idle or automatic strategy with an idle setpoint temperature above freezing.



Chapter 5

Design Considerations

Before designing the snow and ice melting system, it is important to educate customers about the system's capabilities and limitations. Proactive communication with customers, especially homeowners, helps manage expectations, limit frustrations and avoid callbacks because they think the system isn't working properly. For example, if the temperature or wind speed exceeds design parameters, educated customers will anticipate some snow or ice accumulation.

This chapter explains what is involved with each step and the logic behind the Uponor Snow and Ice Melting System design.

Chapter 6 offers a step-by-step design tutorial that describes how to read and use the various charts in the appendices to size snow and ice melting systems.

Snow and Ice Melting Performance

Snow and ice melting systems must be designed to perform to the customer's needs and expectations. There are many ways to design a

snow and ice melting system.

They vary in the spacing of tubing, the BTU/h required, how the area is insulated, the depth of the concrete and the controls selected to run the system.

There is a school of thought that says a snow and ice melting system's performance can and should be based on its ability to melt a given number of inches of snow in an hour. Uponor looks at the performance of a snow and ice melting system somewhat differently.

Just as it is impossible to predict what the next snowflake to fall out of the sky will look like, it is difficult to predict what kind of snow will fall. It could be a light and fluffy snow shower, a heavy wind-driven snow, sleet, freezing rain or even an ice storm. Many factors affect the ability of a system to melt snow. The most critical are:

- The density of the snow
- The outdoor temperature
- Wind conditions
- Slab surface temperature

Density of Snow — Snow most commonly forms at temperatures between -10 and 40°F (-23.33 and 4.44°C). The density can be dramatically different from snowfall to snowfall making it an important consideration when determining how much energy will be required to melt the snow.

Depending upon the air temperature, snow varies in its density. The major contributing factor to the density of snow is its moisture content. The warmer the air temperature during the snowfall, the greater the amount of moisture in the snow. The colder the air temperature during the snowfall, the less the moisture content will be. On average, snow is 10% moisture content. So, a 10-inch snowfall would amount to approximately 1 inch of rain at a warmer temperature.

If the snow is light and fluffy, it is easier to melt because it is relatively low in density. Conversely, 2 inches of heavy moist snow is more difficult to melt because it is denser and requires more energy to melt.

Outdoor Design Temperature — Snow and ice melting systems are typically designed to melt snow at 0°F (-17.78°C) with a 10-mph wind. Local conditions may require higher or lower design temperatures. With the exception of Class 3 designs (e.g., helipads, emergency entrances), the outdoor design temperature is rarely selected below 0°F (-17.78°C). (See classifications of design definitions later in this chapter.)

There is a point at which a design may become financially difficult to justify for operation in Class 1 and some Class 2 applications. In those situations, you can program the Uponor pro Series controls with a cold weather cut-off (CWCO) temperature. This allows the owner to automatically turn the system off at a desired temperature. The system automatically restarts as soon as the outdoor temperature rises above the CWCO temperature.

Note: It is important to understand and communicate to customers that as temperature and wind speed exceed design conditions, the snow and ice melting surface may freeze over. As weather conditions return to design, the system will melt the snow and ice that may have accumulated.

Wind Conditions — A snow and ice melting system is often unaffected if the outdoor temperature drops slightly below design. Wind speeds greater than design conditions will affect system performance more adversely. Strong winds steal heat energy from a slab faster than in calm conditions. The presence of buildings, landscaping or even snow fences can reduce the negative effect of wind on a snow and ice melting slab.

Surface Temperature — The slab surface temperature is the result of supply fluid temperature, flow, tubing on-center

distance and climatic conditions. The performance charts in **Appendix C** show the surface temperatures at varying climatic conditions, on-center distances and BTU/h/ft² loads. These performance charts outline where the BTU/h/ft² and required supply fluid temperatures increase or decrease as the design conditions become more or less severe. Typically, design surface temperatures vary from 35 to 45°F (1.67 to 7.22°C).

All these factors combined make it almost impossible to predict with reasonable accuracy the performance of a snow and ice melting system in terms of the number of inches that can be melted in an hour.

The Uponor solution is to design the system based on outdoor climatic conditions. Following Uponor-specific design charts will ensure a high performance snow and ice melting system.

Classification of Design

Snow and ice melting designs fall into one of three classification levels (1, 2, 3). The higher the classification, the higher the BTU/h/ft² load. The on-center recommendations shown with each class are subject to a reduction in on-center distance as the climatic conditions become more severe or the end-user's requirements become more stringent.

Class 1 — Residential driveways, sidewalks or other non-critical surfaces. Tubing can be installed up to 12 inches on center.

Class 2 — Commercial public-use driveways, sidewalks or other public-use surfaces. Tubing usually installed 9 inches on center.

Class 3 — Helipads, emergency entrances or other critical-use surfaces. Tubing usually installed 6 inches on center.

Installation Methods

Refer to **Chapter 4** for information pertaining to installation methods.

Supply Fluid Temperature

The design supply fluid temperature is determined by climatic conditions, BTU/h/ft² requirements and the tubing on-center distance. As the climatic conditions warm up or become less severe, the BTU/h/ft² load reduces and results in a reduction in supply fluid temperature to the slab.

Limitations — Limitations to supply fluid temperatures are due to construction material and not the PEX tubing. The maximum supply fluid should not exceed 150°F (65.56°C) for concrete installations. It may not be possible to meet the customer's design request due to limitation of the medium. Consult your local code officials for any additional information on the maximum fluid temperatures that can be operated through these different construction mediums.

Tubing On-center Distance — For most residential snow and ice melting designs, 12 inches on-center spacing is recommended, if design requirements are met. If the calculated supply fluid temperature exceeds the temperature limitations for concrete or sand, it may be necessary to install the tubing at 9 or 6 inches on center to reduce the supply fluid temperature requirements (see **Appendix C**). Reducing the on-center distance reduces the flow requirement per loop and the supply fluid temperatures for the same climatic conditions (air and wind). Reducing the on-center distances also increases the amount of tubing and manifold outlets required.

The on-center distance of the tubing layout impacts the

performance of a snow and ice melting system and it is important to understand why. Designing to the outdoor conditions (outdoor temperature and wind speed) and surface temperature for melting the snow or ice is the starting point. Whether the tubing is 12 or 6 inches on center, the load required is the same to achieve these design parameters. However, the supply water temperature requirement is lower for 6 inches versus 12 inches under the same conditions.

The on-center distance of the tubing layout affects the supply water temperature required to meet the performance conditions. The tighter the tube spacing, the lower the water temperature for the same design conditions. Closer tube spacing can be useful in meeting design conditions without exceeding water supply temperatures for the installation method and in accelerated slab warm up.

For all types of installations, residential, commercial or industrial, it is normal for tube spacing to vary from 6 to 12 inches on center. Distances vary depending upon the required performance and traffic. For example, steps, hospital emergency ramps and access areas should not be installed at on-center distances greater than 6 inches because it is essential that these areas are snow and ice-free.

It is recommended not to install tubing with spacing greater than 12 inches on center. Some installations, even with the tubing installed at 12 inches on center, can experience striping depending on tubing depth and control strategy employed. Striping can be seen visually on the surface as the slab begins to melt snow. The areas directly over the tubing

will be melted where as the areas between the tubing will still have snow. Normally, this is a temporary situation that remedies itself as the slab comes to temperature.

Keep in mind that the tubing in the slab is the distribution system. If you limit the amount of distribution (tubing) in the slab, you will experience reduced response times, and in worst cases, it will not deliver the amount of BTU/h fast enough to keep up with the slab loss. In other words, a system failure.

Insulation

The use of insulation around the snow and ice melting slab can have a significant effect on the system's ability to perform. When considering insulation, it is important to evaluate the following:

- Compressive strength (application)
- Compaction over time
- Moisture resistance
- R-value (heat-transfer resistance)

Always use an under-slab rated product, as standard fiberglass insulations will not meet the insulating value once it is compressed. Be sure that the insulation selected meets local code and building requirements.

Uponor recommends a minimum thickness of 2-inch high-density board for use as perimeter and horizontal insulation. Typically, this gives an R-value of 10.0 (check manufacturer information), and provides a durable surface to walk on while installing the tubing. There are new options for insulation entering the market. Ensure that these products meet the vertical load and compression requirements for under slab installations. Refer to

the project engineer for guidance.

Remember, the heat loads (BTU/h/ft²) in snow-melting systems are much greater than typical home heating systems. Using a higher R-value insulation reduces the energy lost to areas around and below the snow-melt area. Uponor highly recommends using insulation for all snow-melt installations.

If there is a high water table or moist soil conditions within 8 to 10 vertical feet of the slab, install a proper drain field beneath the slab. Moisture in the subsoil can create a tremendous rate of downward heat loss. Installing a vapor barrier beneath the slab insulation will not stop the downward migration of heat energy.

Amount of Tubing Needed

To determine the amount of tubing needed based on its on-center placement, use the formulas below.

Tubing 6 inches o.c.:

Square footage x 2.0 =
Feet of active tubing

Tubing 9 inches o.c.:

Square footage x 1.333 =
Feet of active tubing

Tubing 12 inches o.c.:

Square footage x 1.0 =
Feet of active tubing

Remember to add the leader distance to the active loop length to obtain the total loop length.

Loop Lengths

Loop lengths vary depending upon the size of tubing used and the installed on-center distance. In general, the smaller the tubing diameter, the shorter the loop length. Consider $\frac{5}{8}$ " PEX as the smallest tubing size for snow and ice melting projects.

The total loop length consists of two separate sections: the active loop and the leader length. The active loop is installed within the heated slab. The leader length is the total distance to and from the manifold and heated slab (including any vertical distance).

Keep the manifolds as close to the snow-melt area as possible. This eliminates any unnecessary heat loss from the un-insulated leader lengths from the snow-melt area to the manifold location.

When considering loop lengths, it is important to remember that higher loads require higher flow rates. Higher flow rates generate higher pressure losses through the tubing. Reducing on-center distances and keeping loop lengths shorter lowers pressure drops when evaluating pump curves and circulator sizing.

Example

Total snow and ice melting area:
115 ft²

Tubing on-center distance:
9 inches

Tubing type and size: $\frac{5}{8}$ " MLC

Distance from melt area to manifold:
15 feet (leader length)

115 ft² x 1.333 = 153 feet of active loop length

153 feet + 30 feet = 183 feet of total loop length

The 115-square foot snow and ice melting area will require one 183-foot loop of $\frac{5}{8}$ " MLC.

The following charts offer the

recommended loop lengths for a given tubing type and size. These recommendations enable the system designer to stay within the parameters necessary to coincide with commonly stocked pumps. These loop lengths are recommendations and should

PEX Loop Lengths

Size	Active Loop	Total Loop
$\frac{5}{8}$ "	225'	250'
$\frac{3}{4}$ "	300'	325'
1"	450'	475'

MLC Loop Lengths

Size	Active Loop	Total Loop
$\frac{5}{8}$ "	255'	380'
$\frac{3}{4}$ "	380'	405'
1"	575'	600'

These charts are based on flow of 0.0102/feet at 120°F fluid temperature, 40% glycol-water mixture. Total loop length is the combination of the active loop length and the leader length. Flow is based on the active loop length. Pressure head drop is based on the total loop length. Total loop values shown reflect pressure head drops below 20 feet of head. Larger projects will require longer loop lengths and greater head drops.

not be viewed as limitations

Uponor recommends that you do not use $\frac{1}{2}$ -inch diameter tubing for snow and ice melting systems. With the high flow requirements of a snow-melt system, smaller diameter tubing produces very high head pressure drops. To counter this, the loop lengths for $\frac{1}{2}$ -inch tubing must be shorter than other larger dimension tubing. Smaller-dimension tubing also dictates closer on-center distances to better accommodate the system's requirements.

Heat Transfer Fluids*

The circulating fluid in a snow and ice melting system is a glycol-water mixture. When used in proper concentrations, the glycol-water

mixture protects the system from damage due to freezing.

Two types of glycol are available: propylene and ethylene. An ethylene glycol-based fluid is usually the first choice for HVAC service because they are less viscous than propylene glycol fluids, which translates into superior heat transfer efficiency and better low temperature performance. However, in some cases the potential for contact with ground water or other potable water supplies or government regulations call for use of a propylene glycol-based fluid. Propylene glycol fluids feature low acute oral toxicity compared to the oral toxicity of ethylene glycol-based fluids.

Uponor recommends propylene glycol as a freeze-protection agent in snow and ice melting systems. Propylene is considered "food grade" or environmentally safe, while ethylene glycol is considered toxic. Neither propylene nor ethylene glycol has any adverse effect on PEX tubing.

Uninhibited or "plain" glycols are sometimes selected for freeze protection because they cost less than inhibited products. But the plain glycols can actually increase the threat of corrosion in your system because they produce organic acids. If left in solution, these acids lower the system pH. If the glycols are not neutralized, the corrosion rate of ethylene glycol on iron is more than 2.5 times greater than water.

Remember, inhibitors designed to stabilize the glycol are beneficial. However, inhibitors designed to prevent corrosion may damage fittings and other metal components in the system when used with non-barrier tubing. An annual maintenance program is required when active chemicals are incorporated into the hydronic snow and ice melting system.

*Source for heat transfer information: The Dow Chemical Company

Consult the glycol manufacturer's recommendations for glycol and inhibitor use.

Automotive antifreeze products are formulated with silicate-based corrosion inhibitors that are well suited to protect aluminum components in automotive engines, but can actually be harmful to your hydronic system. In hydronic systems, where flow tends to be less turbulent, the silicates in automotive antifreeze can coat and foul heat-transfer surfaces and interfere with the system, reducing energy efficiency. Silicate-based inhibitors can also significantly shorten the life of pump seals.

Finally, manufacturers of automotive antifreeze recommend replacing their fluids every two or three years. In contrast, quality heat transfer fluids — which contain inhibitors designed to maintain fluid pH and protect the metals commonly used in hydronic systems — can last 20 years or more with proper maintenance.

Caution: Do not use automotive antifreeze in any hydronic heating or snow and ice melting system. With few exceptions, automotive antifreeze is an ethylene-glycol based solution.

For long-term, maintenance-free operation, heat transfer fluids should only be diluted with good quality potable water with a pH between 9 and 10. Good quality water contains only minute traces of calcium (<50 ppm), magnesium (<50 ppm), chloride (<25 ppm), and sulfate (<25 ppm), and less than 100 ppm of total hardness as CaCO₃. If good quality water is not available for your installation, prediluted solutions of heat transfer fluids are available from manufacturers like The Dow Chemical Company.

Burst Protection — Burst protection is required when a system is inactive during the winter, and

Volume Percent Glycol Concentration Required for Freeze Protection Using DOWFROST™* Fluid

Temp. °F	Temp. °C	Percentage
20	-7	18%
10	-12	29%
0	-18	36%
-10	-23	42%
-20	-29	46%
-30	-34	50%
-40	-40	54%
-50	-46	57%
-60	-51	60%

*Trademark of The Dow Chemical Company

Note: These figures are examples only and may not be appropriate to your situation. Generally, for an extended margin of protection, you should select a temperature in this table that is at least 5°F (3°C) lower than the expected lowest ambient temperature. Inhibitor levels should be adjusted for solutions of less than 20% glycol. Contact Dow for information on specific cases or further assistance.

adequate space for expansion of an ice/slush mixture is available. When system burst protection is desired, glycol requirements are lower. Burst protection is suitable for chilled water systems, lawn sprinkler systems and other systems that are dormant in the winter. Do not use burst glycol concentrations to protect snow and ice melting systems.

Freeze Protection — Freeze protection is important in systems that must operate all winter, requiring the fluid to circulate at low temperatures. Freeze protection is also necessary if the system offers inadequate volume of expansion of an ice/slush fluid mixture. The fluid in any system that must be protected in the event of power or pump failure should contain sufficient glycol for freeze protection. For freeze protection, choose a glycol solution concentration that prevents the formation of ice crystals at a temperature of at least 5°F (3°C) colder than the lowest expected ambient temperature.

The percentage of glycol needed in the solution depends on the climatic condition of the area. A 40% glycol to 60% water solution (by volume) is common. Consult with the respective glycol manufacturer for the proper level of mixture for a given area. View the chart above.

Fluid Flow — Total fluid flow for the entire system is based on the required BTU/h and the differential temperature selected. Flow per loop is determined by BTU/h/ft², tubing on-center distance and the differential temperature.

Differential Temperature (ΔT) — Differential temperature is the temperature difference between the supply and the return fluid temperatures.

When designing a system, the differential temperature for snow and ice melting systems is typically designed at a 25°F ΔT. This is the basis for the design. System flows and circulator-sizing information can be determined once the design differential temperature is selected.

Under actual operating conditions, the differential temperature varies based on velocity of flow and consumption of energy due to climatic conditions. If the heat loss from the slab increases, the differential temperature increases for a given flow rate. If the heat loss decreases, the differential temperature decreases. Differential temperatures are listed in degrees Fahrenheit.

Pressure Loss — As the heated fluid moves through the tubing there is a loss of pressure associated with this movement. The loss of pressure is listed in pounds per square inch (psi). To convert this value into pump head pressure, multiply the psi by 2.306. The resulting value is listed in feet of pump head pressure. Pressure loss or feet of head is required when selecting the system circulator.

For the snow and ice melting system, flow is based on the length of tubing in the slab (active loop). The leader length is the amount of tubing from the manifold location (supply) to the slab and back (return). Together, the active loop length and the leader length equal the total loop length. Pump head pressure drop is computed with the given flow for a loop and the total loop length. The longer the total loop length, the greater the head pressure drop. Refer to the pressure loss charts in the appendix for the tubing being used on the product.

Tubing Layout Considerations

Refer to **Chapter 4** for information about tubing layout considerations.

Manifold Considerations

Uponor offers three manifolds for snow and ice melting applications.

Uponor TruFLOW Manifolds

— The tubing size used in the snow and ice melting system

determines the type of manifold used. Typically used in residential and small commercial installations, the TruFLOW manifold is used with $\frac{3}{8}$ " PEX and MLC tubing for snow and ice melting applications. These manifolds are capable of flow balancing, flow isolation and temperature indication.

Note: When used for snow and ice melting, the TruFLOW manifolds are compatible only with $\frac{5}{8}$ " PEX and MLC tubing. Larger tubing sizes cannot be connected to the manifold.

2" Copper Valved Manifolds — These valved manifolds are used with $\frac{5}{8}$ " and $\frac{3}{4}$ " PEX and MLC tubing, and are typically used in commercial applications. The manifolds come with either a ball valve or a combination ball/balancing valve on each outlet. The ball valves on these manifolds are for isolation only. Do not attempt to balance with ball valves. If balancing is required, use the manifolds with the combination ball/balancing valve. Refer to **Chapter 3** for additional information.

HDPE Manifolds — These manifolds are used with $\frac{3}{4}$ " and 1" PEX tubing, and are typically used in commercial applications. HDPE manifolds do not feature an oxygen-diffusion barrier, so they can only be used in systems free of ferrous components. Refer to **Chapter 3** for additional information.

Caution: Do not exceed 140°F (60°C) supply fluid temperature to HDPE manifolds and tubing.

HDPE manifolds are not capable of individual loop balancing unless a balancing feature (e.g., flow setter) is added to each loop. These manifolds are usually used in direct burial applications, and the use of valves on the manifold is not desired.

To avoid having to flow balance across the manifold, ensure that loop lengths are within 3% of each other. With the supply and return mains to the manifold piped in a reverse-return configuration and the loops within 3% of each other in length, the manifold will self balance.

Example

If the designed loop lengths for a project is 333 feet, the installed loop lengths can vary no more than 5 feet from this designed loop length. The acceptable range of loop lengths in this example is 328 to 338 feet ($333 \times 0.03 = 10$). A loop length outside this range would require flow balancing for all loops on the manifold.

Brazed-plate Heat Exchangers — Brazed-plate heat exchangers offer isolation and heat transfers between boiler water and snow-melting fluid. Heat exchangers feature two separate chambers, or sides to separate the boiler water from the snow-melting system fluid. The hot boiler water pumps through the heat exchanger, warming up the actual walls of the exchanger itself. Snow-melting system fluid pumps through the other side of the exchanger and is warmed as it comes in contact with the hot walls of the exchanger. The boiler water and the snow-melting system fluid never mix.

Heat exchangers are most commonly used to deal with the issue of oxygen diffusion corrosion when non-barrier Uponor AquaPEX tubing is used for snow and ice melting. Non-ferrous components are used along with the non-barrier tubing on the snow-melting side of the heat exchanger. This means using a bronze or stainless steel circulator with non-ferrous flanges, a potable water-type expansion tank, a brass or bronze air separator and all non-ferrous hard piping. Do not use steel or cast-iron piping or other materials with non-barrier tubing.

For snow and ice melting applications, it is more economical and practical to isolate the snow-melt area. If the snow and ice melting part of the system is ever shut down for a period of time, it will not affect the rest of the heating system. It also keeps glycol away from the heat of the boiler. The higher the temperature the glycol solution is subjected to, the shorter its life cycle. In addition, some seals on boilers are not compatible with some glycols. Going through a heat exchanger also reduces, if not eliminates, the issue of cold-water return to the boiler. Refer to the boiler manufacturer for more information. Finally, the cost of using glycol for the entire heating instead of just the snow melting part of the system can be significant.

Control Strategies

Refer to **Chapter 7** for information concerning control strategies and corresponding controls.

Operational Considerations

Listed below are several considerations common to snow and ice melting applications.

Preventing Shock to the Slab

— A danger for a snow-melt slab is thermal shock. Shock happens when the slab is heated too quickly causing the concrete to rapidly expand and fracture.

For any control strategy that is designed for on and off operation or shifting between an idle setpoint temperature and a snow-melt temperature, the differential temperature between the supply and return fluid from the slab must be monitored. The control must have a sensor on the supply and return mains to the snow-melt slab. The control must also be able to interpret the difference in temperatures and

take the appropriate action — either increasing or decreasing supply water temperature to slowly warm the snow-melt slab.

If the maximum differential temperature (MAX ΔT) programmed in the snow-melt control is 30°F, the control will monitor the return temperature and provide a supply water temperature 30°F higher than the return. As the fluid returns warmer, the control will increase the supply fluid temperature — keeping within the 30°F (-1.11°C) differential temperature. This monitored heating of the slab will continue until the slab reaches the designated temperature.

A possible exception for monitoring would be for a constant idle control strategy (see **Chapter 7**) that becomes active well above freezing and the supply fluid temperature is modulated in respect to outdoor temperature. Constant idle applications are not designed to be turned on and off during the season. They operate continuously throughout the heating season.

Bridging Effect — When a control strategy allows the slab to cool to ambient temperatures, or idle below freezing, there is often a lag in response to falling snow. After a fair amount of snow accumulates on the slab, the system experiences a situation called “bridging.” Bridging takes place between the surface of the slab and the corresponding surface of the snow pack. The snow melts against the surface of the slab. Small caves or bridges form over the heated slab. Where the slab loses physical contact with the snow, the transfer of heat energy drops dramatically.

From the surface of the snow, there may be little or no indication that the snow and ice melting system is operating. Eventually the snow will melt from the surface.

If bridging occurs, you can drive a vehicle across the slab to compact the snow against the slab, which will accelerate the melting.

One way to avoid bridging is to make sure the slab is in the heating phase prior to the snowfall.

Drainage — An automatic system idling above freezing or a constant idling system results in minimal run off. Both strategies warm surfaces that melt snow quickly. Much of the moisture generated is lost to the atmosphere in the form of evaporation.

Drainage can be an issue for systems that operate intermittently through the season. Once snow has accumulated on the slab, some run-off will occur.

Plan drains at the point of flow across the slab and the area where the heated slab ends. Remember to provide a form of heat for the drains. The run-off from the snow-melt area will refreeze as soon as it makes contact with the non-heated area.

Concrete Installation — The concrete depth affects the performance of a snow and ice melting system. The thicker the slab, the less accuracy and response with regards to performance. A depth of 4 to 6 inches is optimal. In addition to the depth of the concrete, it's important to watch where the tubing sits in the concrete after the pour.

A more effective system results when the tubing is closer to the top of the pour at 3 to 4 inches from the surface. Whenever possible, you should be present during the concrete pour to ensure system integrity.

Slopes — The slope of a driveway or walkway does not impact the performance of a snow and ice melting system.

What should be considered is the tubing layout pattern. Never run loops up and down the slope. Always lay the tubing perpendicular to the slope and ensure that the supply side enters from the up-slope location. This helps eliminate air traps in the loops.

If a snow and ice detector is used in a slope installation, ensure the detector is installed on a flat area surrounding the device. If the detector is installed level with the slope, false readings or early shutdown of the system could result, because the snow or ice melts from the detector before the rest of the slab surface is clear.

Sizing Mains — With any hydronic system, it is important to properly size the supply and return mains to the snow-melt area. The fluid velocity should be held fairly consistent across the system. Do not size the tubing for velocities below 1.5 feet per second (f/s). Flow velocities below 1.5 f/s will make it difficult if not impossible to remove entrapped air from the system. For smaller dimensioned tubing (less than 2 inches), do not exceed 8 f/s. Velocities greater than 8 f/s may cause erosion damage to metal components within the fluid pathway. Refer to **Appendix G** for velocity charts.

For a closed-loop system with ferrous components, choose Uponor's large dimension Wirsbo hePEX tubing. This tubing offers an EVOH oxygen diffusion barrier on the outside of the tubing. Tubing is available in dimensions 1" thru 3". Refer to **Chapter 3** for more information.

For a closed-loop system with non-ferrous components or an isolated system, choose Uponor's HDPE tubing. This tubing does not offer an oxygen diffusion barrier. Tubing and fittings are connected through heat-fusion welding. Tubing is available in 2, 3 and 4-inch dimensions. Refer to **Chapter 3** for more information.



Chapter 6

Design Tutorial

Designing an effective snow and ice melting system requires some preparation. The step-by-step design tutorial in this chapter will help you estimate the amount of tubing needed and establish other design parameters.

The sample exercise uses 5/8" MLC, however, the steps also apply to Wirsbo hePEX and Uponor AquaPEX as well as to larger tubing sizes. Please refer to **Appendices C** and **E** to guide you through the tutorial. A quick-design worksheet template, which can be copied and used for future installations, is available in **Appendix A**. The detailed manifold worksheet, containing designer notes, is in **Appendix B**. The Uponor Advanced Design Suite software can also design the system.

Step 1 — Identify the outside air temperature and wind speed using **Appendix C**. The majority of snowfall occurs between 5 and 34°F (-15 and 1.11°C). This example assumes a system to be designed at 5°F (-15°C) with a 10-mph wind.

Step 2 — Identify differential temperature (ΔT) for the system design. All charts in this manual are based on a 25°F (12.5°C) differential temperature.

Step 3 — From the charts in **Appendix C**, select the surface temperature you want the system to achieve at design. This example uses 38°F (3.33°C).

Step 1a.	Design temperature	5°F (-15°C)
Step 1b.	Wind speed	10 mph
Step 2.	Differential temperature	25°F (12.5°C)
Step 3.	Surface temperature	38°F (3.33°C)
Step 4.	BTU/h/ft ² load	
Step 5a.	Supply fluid temperature	
Step 5b.	Tubing (o.c.) distance	
Step 6.	Area in square feet	
Step 7.	Total BTU/h	
Step 8a.	Tubing type	
Step 8b.	Tubing size	
Step 9.	Total amount of tubing	
Step 10a.	Active loop length	
Step 10b.	Number of loops	
Step 11a.	Leader length	
Step 11b.	Total loop length	
Step 12.	Percentage of glycol (%)	
Step 13a.	Flow per foot of tubing (gpm)	
Step 13b.	Flow per loop (gpm)	
Step 14.	System flow (gpm)	
Step 15a.	Head pressure drop/ft	
Step 15b.	Head pressure drop/loop	

Step 4 — Determine the BTU/h/ft² load for the system at the selected climatic conditions and surface temperature. Starting at the climatic condition row [5°F (-15°C) at 10 mph] in **Appendix C**, move to the right until you intercept the vertical column for 38°F (3.33°C) surface temperature. The square foot load for this example is 126 BTU/h/ft².

If you have any difficulty reading the charts, refer to the chart explanation at the beginning of **Appendix C**.

Step 5 — Determine the supply fluid temperature. Within the block designating the BTU/h/ft² load in **Appendix C**, you will see three temperature blocks beneath the load. These are the supply fluid temperatures at different tubing on-center (o.c.) distances. The on-center distances from left to right are: 6 inches, 9 inches and 12 inches.

Note: If the temperature exceeds the recommended maximum (150°F (65.56°C) for concrete), reduce the tubing on-center distance until the supply fluid temperature is below the recommended maximum.

The supply fluid temperature for this example is 132°F (55.56°C). This example uses 9 inches on center.

Step 6 — Identify the installation area. This example assumes a 1,700-square foot drive to an office building (17 feet x 100 feet).

Step 7 — Determine the BTU/h requirements for this design (boiler sizing). Take the BTU/h/ft² load and multiply it by the area to be heated.

For this example, multiply 126 BTU/h/ft² by 1,700 square feet for a total load of 214,200 BTU/h.

Step 8 — Determine the type and size of tubing for the design. This example uses 5/8" MLC.

Note: Tubing smaller than 5/8" is not recommended for snow and ice melting applications due to the increase in flow requirements. With few exceptions, 5/8" and 3/4" tubing will meet the requirements for most snow and ice melting applications.

Step 9 — Determine the amount of tubing required. Use the multiplier shown below for the appropriate tubing on-center distance to obtain the amount of active tubing for the project.

6" o.c. = 2.00 multiplier
 9" o.c. = 1.33 multiplier
 12" o.c. = 1.00 multiplier

Multiply the square footage of the area by 1.33 (9 inches o.c.). 1,700 x 1.33 = 2,261 feet of active tubing is required for the installation.

Step 10 — Determine the average active loop length and the number of loops for the manifold. The average active loop length is used to calculate preliminary flow and pressure loss. When the design is complete and actual loop lengths are known, flow and pressure loss can be more accurately determined. Refer to the Manifold Worksheet in **Appendix B**.

Divide the total amount of active tubing required by 200 feet (recommended average loop length for 5/8" tubing).

2,261 feet (tubing required) ÷ 200 feet = 11.3 loops.

Round the number of loops to the nearest whole number and divide that new value into the amount of tubing.

2,261 feet divided by 11 loops = 206 feet per loop.

The number of loops for this manifold is 11 with an average active loop length of 206 feet.

Note: It is recommended not to exceed the flow limit for the manifold. Add additional manifolds if necessary.

Step 1a.	Design temperature	5°F (-15°C)
Step 1b.	Wind speed	10 mph
Step 2.	Differential temperature	25°F (12.5°C)
Step 3.	Surface temperature	38°F (3.33°C)
Step 4.	BTU/h/ft² load	126
Step 5a.	Supply fluid temperature	132°F (55.56°C)
Step 5b.	Tubing (o.c.) distance	9"
Step 6.	Area in square feet	1,700 ft²
Step 7.	Total BTU/h	214,200
Step 8a.	Tubing type	MLC
Step 8b.	Tubing size	5/8"
Step 9.	Total amount of tubing	2,261'
Step 10a.	Active loop length	206'
Step 10b.	Number of loops	11 loops
Step 11a.	Leader length	
Step 11b.	Total loop length	
Step 12.	Percentage of glycol (%)	
Step 13a.	Flow per foot of tubing (gpm)	
Step 13b.	Flow per loop (gpm)	
Step 14.	System flow (gpm)	
Step 15a.	Head pressure drop/ft	
Step 15b.	Head pressure drop/loop	

Step 11 — Determine the leader length and total loop length for the tubing. The leader length is the amount of tubing between the active heated panel and the manifold location to include any vertical variations. Add the leader length to the active loop length to determine the total loop length.

For this example, use 20 feet of leader length for a total loop length of 226 feet per loop.

Step 12 — Select the percentage of glycol mixture used in the system. Refer to **Chapter 5** of this manual for additional information concerning glycol. In this example, use 40% propylene glycol.

Step 13 — Determine flow in gallons per minute (gpm) per foot of tubing and per loop.

Refer to the flow charts in **Appendix C**. These charts are listed after the performance charts.

1. Enter the charts at the BTU/h/ft² load. This example uses 126 BTU/h/ft².
2. Move horizontally to the appropriate percentage of glycol column. This example uses 40% glycol.
3. To determine the flow value per foot of active loop, follow the BTU/h/ft² load row until it intersects the respective tubing on-center column. This example uses 9 inches on center. The flow per foot in this example is 0.0081 gpm.
4. Multiply the value found in **Step 13** with the active loop length. The active loop length for this example is 206 feet. 206' x 0.0081 gpm = 1.67 gpm per loop.

Step 14 — To obtain the flow for the system, multiply the flow per loop by the number of loops on the system.

$$1.67 \text{ gpm/loop} \times 11 \text{ loops} = 18.37 \text{ gpm}$$

Step 15 — Determine the pump head pressure drop. Pressure loss charts are available in **Appendix E** for the different sizes of MLC tubing at 30%, 40% and 50% water/glycol solutions and for different fluid supply temperatures. If the supply temperature is between two charts, use the lower temperature chart.

1. Find the correct pressure loss chart in **Appendix E**. (This example uses 5/8" MLC at 40% glycol using the 120°F column.)

2. Enter the chart in the "gpm" column at the flow/loop value of 1.67 (as determined in Step 13b). Since 1.67 is between 1.6 and 1.7 round to the higher rate of 1.7.
3. Read the feet of head drop per foot under the appropriate fluid temperature (120°F). The feet of head drop per foot in this example is 0.03090.
4. Multiply the feet of head value by the total loop length. 0.03090 x 226 = 7.0 feet of head drop

Step 1a.	Design temperature	5°F (-15°C)
Step 1b.	Wind speed	10 mph
Step 2.	Differential temperature	25°F (12.5°C)
Step 3.	Surface temperature	38°F (3.33°C)
Step 4.	BTU/h/ft ² load	126
Step 5a.	Supply fluid temperature	132°F (55.56°C)
Step 5b.	Tubing (o.c.) distance	9"
Step 6.	Area in square feet	1,700 ft ²
Step 7.	Total BTU/h	214,200
Step 8a.	Tubing type	MLC
Step 8b.	Tubing size	5/8"
Step 9.	Total amount of tubing	2,261'
Step 10a.	Active loop length	206'
Step 10b.	Number of loops	11 loops
Step 11a.	Leader length	20'
Step 11b.	Total loop length	226'
Step 12.	Percentage of glycol (%)	40%
Step 13a.	Flow per foot of tubing (gpm)	0.0081
Step 13b.	Flow per loop (gpm)	1.67
Step 14.	System flow (gpm)	18.37
Step 15a.	Head pressure drop/ft	0.03090
Step 15b.	Head pressure drop/loop	7.0 ft hd



Chapter 7

Control Strategies

This chapter outlines varying levels of control strategies along with the effect that insulation variables can place on the performance of the system. When planning and designing the snow-melting system, it is important to consider control strategies that support the intended need of the customer and the type of heat source available to the system.

Supply Fluid Tempering

Uponor recommends the use of variable speed injection mixing for snow and ice melting applications. The use of injection circulators provides a larger range of support to the snow-melt load. The use of a floating action or modulating valves can quickly require an upsizing due to the heavier flow requirements.

Control Strategies

There are three primary ways in which to operate snow and ice melting systems.

1. Idle Operation
2. Semi-automatic
3. Automatic

Idle Operation

When the snow melting system starts from a cold temperature, there may be a long time delay before the slab is warm enough to melt snow. This time delay allows snow to accumulate on the slab which is not acceptable in some commercial and institutional applications. To decrease the start-up time, the slab can be pre-heated to maintain a minimum temperature. This is known as the Idle temperature. Idling requires large energy consumption and is generally recommended for institutional and/or commercial installations where safety concerns are paramount. Idle is shown on the display when the control is in idle operation.

When designing a snow melting system, an engineer may specify the amount of allowed snow accumulation as the Snow-Free Area Ratio. There are three different levels.

A Snow-Free Area Ratio of 1 is defined as a system that melts all snow as it falls with no allowed accumulation. This requires that the Idle temperature be set just below

freezing. Examples of these types of applications include:

- Hospital emergency areas
- Helicopter landing pads
- Parking garage ramps

A Snow-Free Area Ratio of 0.5 is defined as a system with partial snow accumulation on the slab but not in all areas. These types of systems may also use idling but usually set at a temperature several degrees below freezing to reduce energy consumption. Applications may include:

- Steep residential driveways
- Commercial sidewalks
- Loading docks

A Snow-Free Area Ratio of 0 is defined as a system that allows snow accumulation. These systems operate the snow melting system from a cold start resulting in the lowest energy consumption costs and the longest times to start melting snow. In this case, set the Idle to off. This is recommended for most residential applications:

- Flat residential driveways
- Patios
- Residential sidewalks

Some systems are designed for keeping a slab surface free of ice rather than free of snow. The most common applications include:

- Car wash bays and aprons
- Aircraft hanger aprons
- Turf conditioning on golf course greens

These systems require the use of idling at or near freezing throughout the winter and may result in high energy consumption.

Under-slab insulation should be considered in this type of application, especially if a high water table or a moist soil condition is present. A high water table is defined as a water table within 8 to 10 vertical feet of the slab. Vertical insulation down to the frost line is recommended to reduce the amount of lateral energy loss.

Semi Automatic

Systems can be designed to be semi-automatic. What differentiates this strategy from a constant idle system is that the start of the melting cycle happens with user interaction, or by pressing the “start” switch. The melt cycle ends when a “time-out” feature where the user sets the specific time interval. The setup or programming is more extensive than the constant idle scenario, but it provides

additional benefits and safety features for the user. The system automatically shuts off as programmed, which eliminates any wasted fuel consumption.

This type of control uses a slab sensor that provides temperature data feedback. Set the control to a temperature to melt snow. Once the desired slab temperature is achieved and the time interval has ended, the control automatically ends the heat demand. This keeps the slab from over-heating, so it operates more economically. For example, set the control at a 38°F (3.33°C) slab temperature and a four-hour run cycle. To start the melting process, press the button on the control. Once the system reaches 38°F (3.33°C) on the sensor, the timer begins. The heat plant continues to cycle and add heat, keeping the slab at 38°F (3.33°C). The snow-melting operation automatically ends after four hours.

A semi-automatic control strategy should incorporate an insulated slab to facilitate a quicker response. Additionally, if a high water table or moist soil condition is present, under-slab insulation with an R-value of at least 10 is mandatory. You must also install a tile system to drain moisture from beneath the heated slab.

The system performance may be dramatically affected if insulation is not installed under and along the slab. Once the system is off for a period of time, the ground will quickly freeze down to the current frost level. Subsequent start-up times will be delayed due to the amount of energy drawn to the frozen subsoil along with the requirements of the slab itself. The lack of insulation will result in increased response times, greater energy consumption, and in worst cases, a failure of the system to perform to specification.

Automatic

A fully automated system requires user input to program the control. Once powered up, the control takes over from there. Automatic controls eliminate human intervention to start and stop the snow-melting system. These systems incorporate a disk or sensor at the surface level of the snow-melting area. These types of sensors offer increased capabilities over conventional slab sensors. As they detect the presence of moisture (snow or ice) at temperatures below 32°F (0°C). Most advanced automated controls provide snow and ice detection, the ability to idle the system (considered as a slab low limit) and react to outdoor ambient conditions. The ability to sense outdoor temperatures offers the option of locking out a heat demand when it is too warm or too cold. These features optimize fuel consumption. Conditions may exist where it is either too cold for snow to fall or too warm for snow to accumulate due to solar exposure.

There is a difference between idle setpoint temperature for the slab and the snow-melt setpoint temperature. To idle a slab under the automatic control strategy, maintain the slab at a setpoint temperature until activated by the control to accelerate into the snow-melt mode. The control then targets the snow-melt setpoint temperature as its new slab temperature. Supply fluid temperatures are adjusted by the mixing control to support this new, higher setpoint temperature.

Often the idling setpoint temperature is just under freezing 28 to 30°F (1.11 to 2.22°C). This allows the system to respond quicker to a call for snow melt than if the slab was allowed to cool down to ambient temperatures. At other times, the specification may require that the slab should not freeze. In this situation, the idle

setpoint temperature is maintained above freezing 34 to 36°F (1.11 to 2.22°C). This setpoint is often used in Class 3 snow-melt applications or when the surface condition of the slab is critical, such as an emergency helipad.

An automatic control strategy should incorporate an insulated slab to facilitate a quicker response. Additionally, if a high water table or moist soil condition is present, under-slab insulation with an R-value of at least 10 is mandatory. You must also install a tile system to drain moisture away from beneath the heated slab.

The system performance may be dramatically affected if insulation is not installed under and along the slab. Once the system is off for a period of time, the ground will quickly freeze down to the current frost level. Subsequent start-up times will be delayed due to the amount of energy drawn to the frozen subsoil along with the requirements of the slab itself. The lack of insulation will result in increased response times, greater energy consumption, and in worst cases, a failure of the system to perform to specification.

Uponor Single-Zone Snow Melt Control

The Uponor Single-zone Snow Melt Control (A3040654) is designed to operate hydronic equipment to melt snow or ice from any surface, including driveways, walkways, patios, business entrances, parking ramps, loading docks, hospital entrances, helipads or car wash bays, and can be set up or programmed to provide all of the strategies detailed within this section.



A3040654 Single-zone Snow Melt Control



A3040095 Aerial Snow Sensor



A3040090 Pavement Snow and Ice Sensor



A3040091 Pavement Snow and Ice Sensor Cup

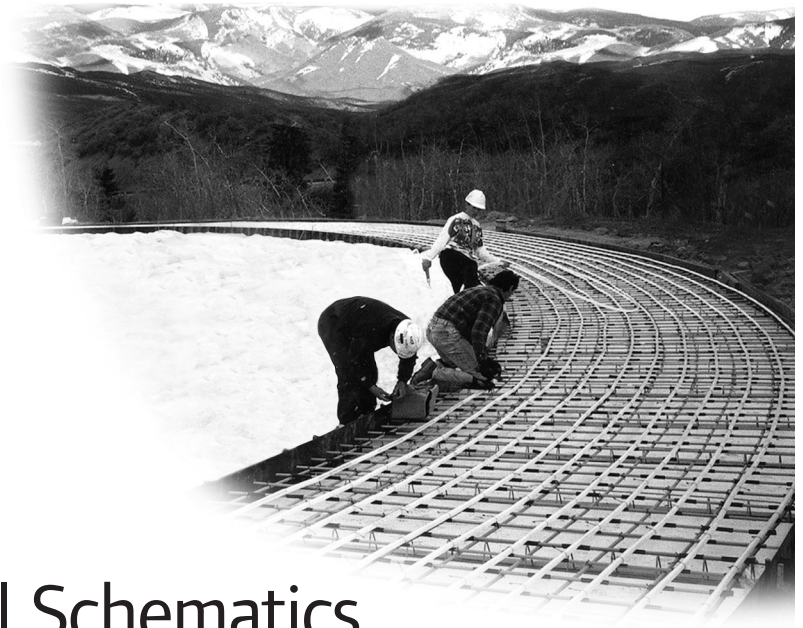

Chapter 8

Piping and Electrical Schematics

The boiler schematics outlined in this chapter are conceptual drawings, which illustrate the various piping and heat plant options available. Actual heating systems must be installed in accordance with the respective local codes.

Refer to the heat source manufacturer's installation and operation instructions for specific near-boiler piping and operating parameters.

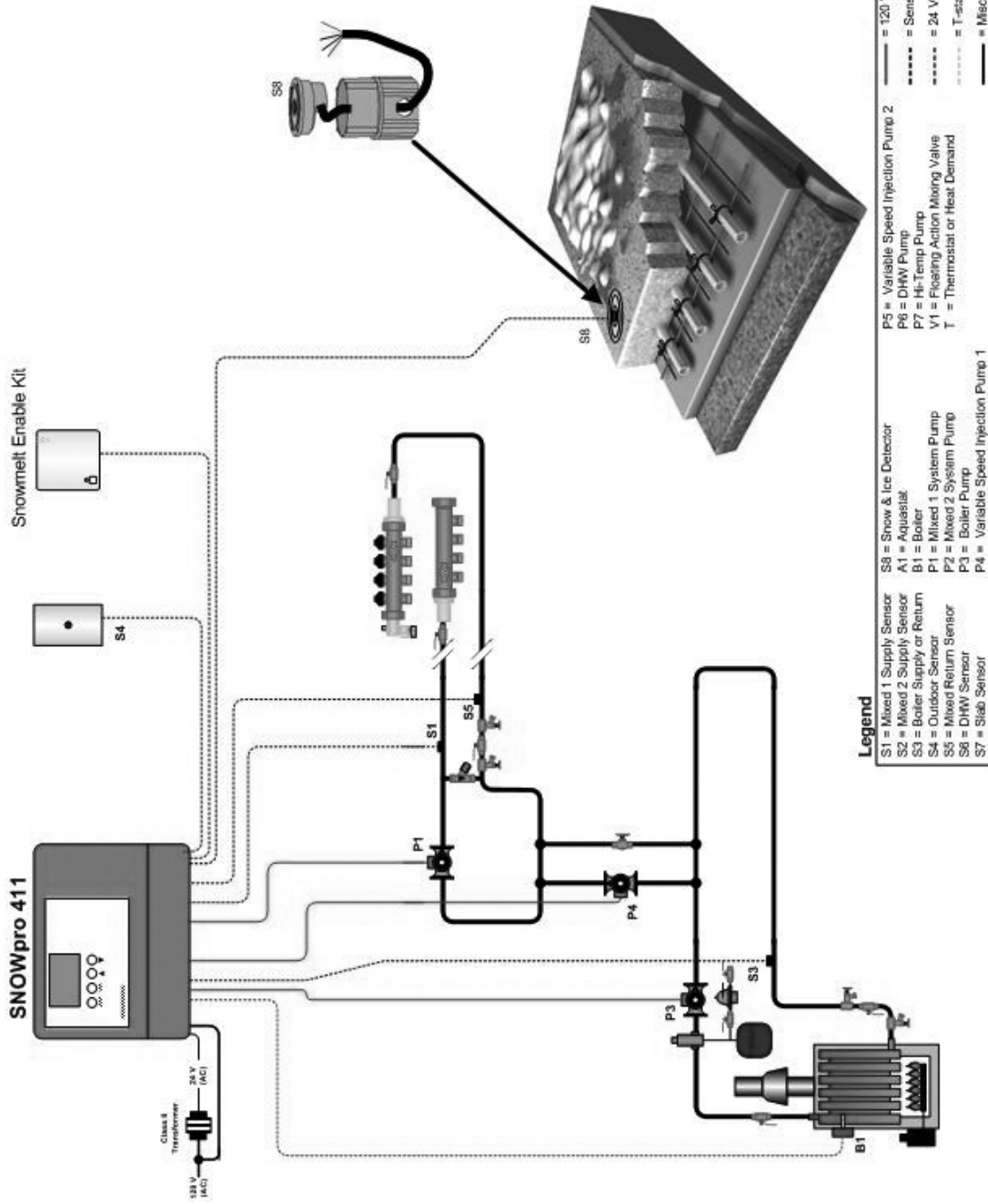

NOTE: This drawing is conceptual only, not an engineered drawing. It is up to the contractor to verify the proper selection, installation, and commissioning of the particular system depicted, including additional equipment, installation notes (not loads greater than the controls specified output ratings), and any safety devices which, in the judgment of the designer, are appropriate. Control components may have been left out on this drawing for clarity. The contractor is responsible for the proper selection, flow control, loop sizing and pump selection, and the responsibility of the installing contractor. Load codes and trade practices must be followed.

Legend

- S1 = Mixed 1 Supply Sensor
- S2 = Mixed 2 Supply Sensor
- S3 = Boiler Supply or Return
- S4 = Outdoor Sensor
- S5 = Mixed Return Sensor
- S7 = Slab Sensor
- S8 = Snow & Ice Detector
- A1 = Aquasist
- B1 = Boiler
- P1 = Mixed 1 System Pump
- P2 = Mixed 2 System Pump
- P3 = Boiler Pump
- P4 = Variable Speed Injection Pump 1
- P5 = Variable Speed Injection Pump 2
- P6 = DHW Pump
- P7 = Hi-Temp Pump
- T = Thermostat or Heat Demand
- V1 = Floating Action Mixing Valve
- V2 = Floating Action Mixing Valve
- V3 = Floating Action Mixing Valve
- V4 = Floating Action Mixing Valve
- V5 = Floating Action Mixing Valve
- V6 = Floating Action Mixing Valve
- V7 = Floating Action Mixing Valve
- V8 = Floating Action Mixing Valve
- V9 = Floating Action Mixing Valve
- V10 = Floating Action Mixing Valve
- V11 = Floating Action Mixing Valve
- V12 = Floating Action Mixing Valve
- V13 = Floating Action Mixing Valve
- V14 = Floating Action Mixing Valve
- V15 = Floating Action Mixing Valve
- V16 = Floating Action Mixing Valve
- V17 = Floating Action Mixing Valve
- V18 = Floating Action Mixing Valve
- V19 = Floating Action Mixing Valve
- V20 = Floating Action Mixing Valve
- V21 = Floating Action Mixing Valve
- V22 = Floating Action Mixing Valve
- V23 = Floating Action Mixing Valve
- V24 = Floating Action Mixing Valve
- V25 = Floating Action Mixing Valve
- V26 = Floating Action Mixing Valve
- V27 = Floating Action Mixing Valve
- V28 = Floating Action Mixing Valve
- V29 = Floating Action Mixing Valve
- V30 = Floating Action Mixing Valve
- V31 = Floating Action Mixing Valve
- V32 = Floating Action Mixing Valve
- V33 = Floating Action Mixing Valve
- V34 = Floating Action Mixing Valve
- V35 = Floating Action Mixing Valve
- V36 = Floating Action Mixing Valve
- V37 = Floating Action Mixing Valve
- V38 = Floating Action Mixing Valve
- V39 = Floating Action Mixing Valve
- V40 = Floating Action Mixing Valve
- V41 = Floating Action Mixing Valve
- V42 = Floating Action Mixing Valve
- V43 = Floating Action Mixing Valve
- V44 = Floating Action Mixing Valve
- V45 = Floating Action Mixing Valve
- V46 = Floating Action Mixing Valve
- V47 = Floating Action Mixing Valve
- V48 = Floating Action Mixing Valve
- V49 = Floating Action Mixing Valve
- V50 = Floating Action Mixing Valve
- V51 = Floating Action Mixing Valve
- V52 = Floating Action Mixing Valve
- V53 = Floating Action Mixing Valve
- V54 = Floating Action Mixing Valve
- V55 = Floating Action Mixing Valve
- V56 = Floating Action Mixing Valve
- V57 = Floating Action Mixing Valve
- V58 = Floating Action Mixing Valve
- V59 = Floating Action Mixing Valve
- V60 = Floating Action Mixing Valve
- V61 = Floating Action Mixing Valve
- V62 = Floating Action Mixing Valve
- V63 = Floating Action Mixing Valve
- V64 = Floating Action Mixing Valve
- V65 = Floating Action Mixing Valve
- V66 = Floating Action Mixing Valve
- V67 = Floating Action Mixing Valve
- V68 = Floating Action Mixing Valve
- V69 = Floating Action Mixing Valve
- V70 = Floating Action Mixing Valve
- V71 = Floating Action Mixing Valve
- V72 = Floating Action Mixing Valve
- V73 = Floating Action Mixing Valve
- V74 = Floating Action Mixing Valve
- V75 = Floating Action Mixing Valve
- V76 = Floating Action Mixing Valve
- V77 = Floating Action Mixing Valve
- V78 = Floating Action Mixing Valve
- V79 = Floating Action Mixing Valve
- V80 = Floating Action Mixing Valve
- V81 = Floating Action Mixing Valve
- V82 = Floating Action Mixing Valve
- V83 = Floating Action Mixing Valve
- V84 = Floating Action Mixing Valve
- V85 = Floating Action Mixing Valve
- V86 = Floating Action Mixing Valve
- V87 = Floating Action Mixing Valve
- V88 = Floating Action Mixing Valve
- V89 = Floating Action Mixing Valve
- V90 = Floating Action Mixing Valve
- V91 = Floating Action Mixing Valve
- V92 = Floating Action Mixing Valve
- V93 = Floating Action Mixing Valve
- V94 = Floating Action Mixing Valve
- V95 = Floating Action Mixing Valve
- V96 = Floating Action Mixing Valve
- V97 = Floating Action Mixing Valve
- V98 = Floating Action Mixing Valve
- V99 = Floating Action Mixing Valve
- V100 = Floating Action Mixing Valve

Project:	Uponor, Inc.
	3925 148th Street West
	Apple Valley, MN 55124
Phone: (800) 321-4739	
Fax: (952) 891-1409	
www.uponor-usa.com	
Drawn by:	Checked by:
Rep:	DATE:

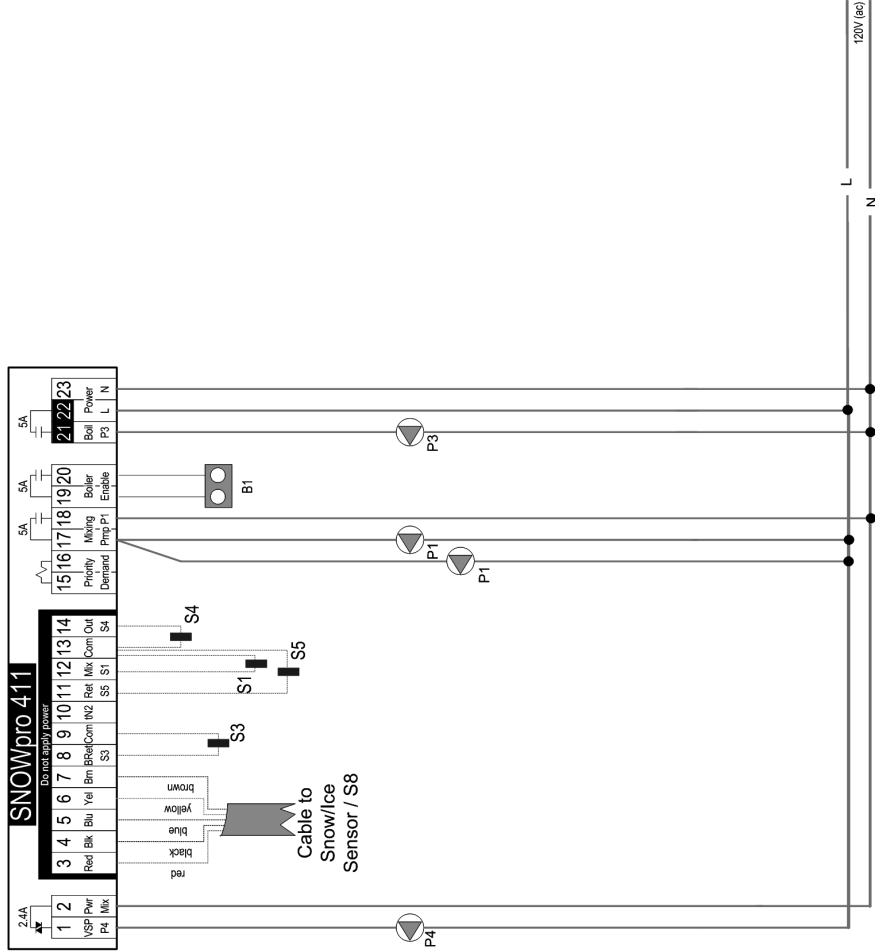

Legend

NOTE: This drawing is conceptual only, not an engineered drawing. It is up to the system designer to determine the necessary components for and the proper installation of the equipment. Isolation relays (for loads greater than the control's specified output ratings), and any safety devices which in the judgement of the designer are appropriate. Certain components may have been left out on this drawing for the purpose of clarity. Mechanical considerations such as line spacing, flow control, piping and pipe direction, is the responsibility of the installing contractor. Local codes and trade practices must be followed.

- S1 = Mixed 1 Supply Sensor
- S2 = Mixed 2 Supply Sensor
- S3 = Boiler Supply or Return
- S4 = Outdoor Sensor
- S5 = Mixed Return Sensor
- S6 = DHW Sensor
- S7 = Slab Sensor
- S8 = Snow & Ice Detector
- A1 = Aquastat
- B1 = Boiler
- P1 = Mixed 1 System Pump
- P2 = Mixed 2 System Pump
- P3 = Boiler Pump
- P4 = Variable Speed Injection Pump 1
- P5 = Variable Speed Injection Pump 2
- P6 = DHW Pump
- P7 = Hi-Temp Pump
- V1 = Floating Action Mixing Valve
- T = Thermostat or Heat Demand

- = 120 V (AC)
- = Sensor Wire
- = 24 V (AC)
- = T-stat Wire
- = Misc.

Project:	
Uponor, Inc.	Phone: 1-800-321-4739
5925 148th Street W.	Fax: 1-952-891-1409
Apple Valley, MN 55124	www.uponor-usa.com
Drawn by:	Checked by:
Rep:	DATE:

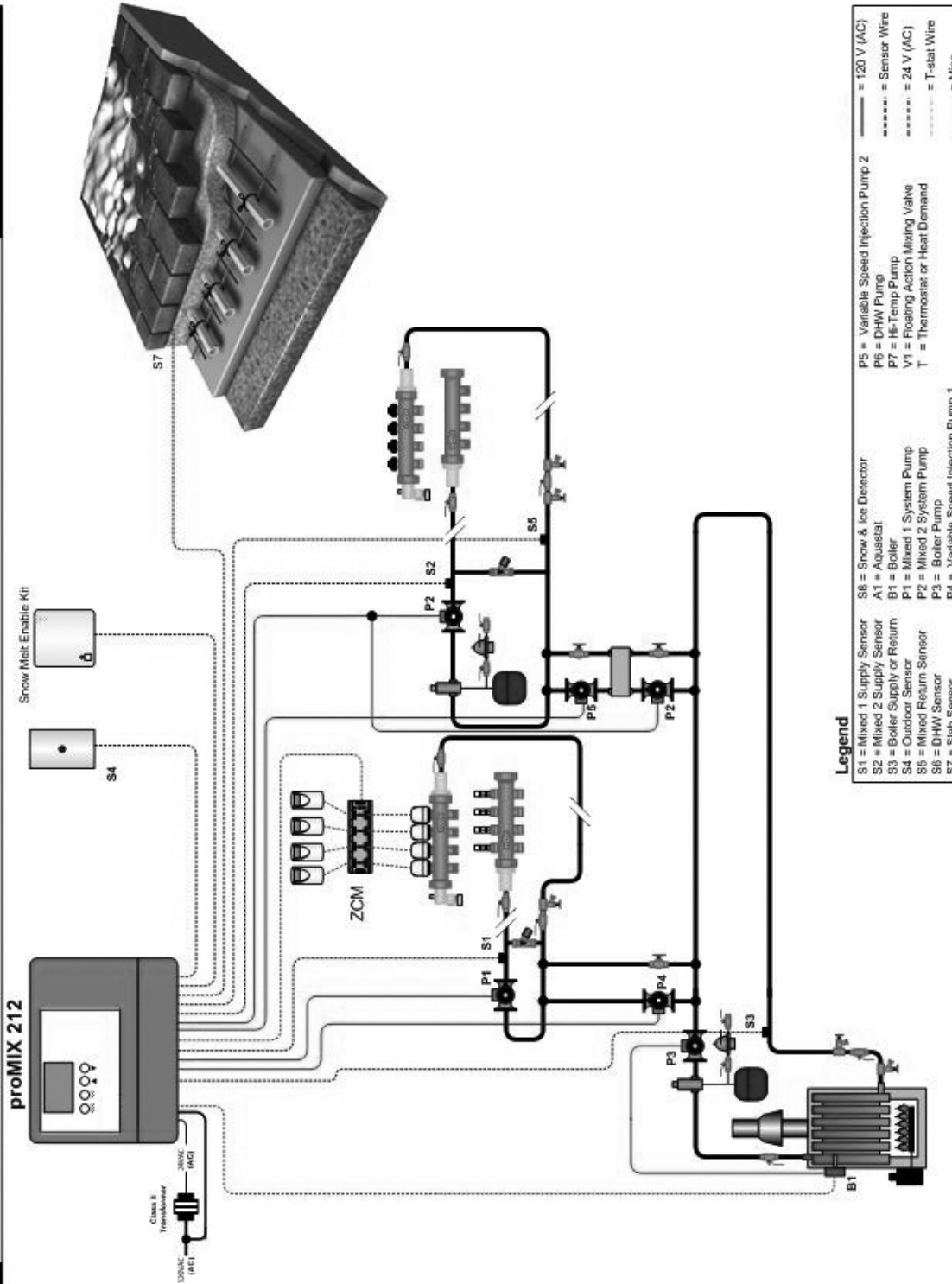

NOTE: This drawing is conceptual only, not an engineered drawing. It is left to the contractor to determine the proper piping and equipment for the particular system design, including additional equipment, isolation-valves (for loads greater than the controls selected output ratings), and any safety devices which, in the judgment of the designer, are appropriate. Control components like those shown on this drawing are carried, pipe sizes and control sequences, as the manufacturer of the installing contractor. Load codes and trade practices must be followed.

Symbols	Tempering Valve	Pump	Air Separator & Expansion Tank w/ fill	Zone Valve	Ball Valve	Flow Check
Floating Action Mixing Valve	Pressure By-Pass Valve <td>Globe Valve <td>Drain Valve <td></td> <td></td> <td></td> </td></td>	Globe Valve <td>Drain Valve <td></td> <td></td> <td></td> </td>	Drain Valve <td></td> <td></td> <td></td>			

Legend

- S1 = Mixed 1 Supply Sensor
- S2 = Mixed 2 Supply Sensor
- S3 = Boiler Supply or Return
- S4 = Outdoor Sensor
- S5 = Mixed Return Sensor
- S6 = DHW Sensor
- S7 = Slab Sensor
- S8 = Snow & Ice Detector
- A1 = Aquastat
- B1 = Boiler
- P1 = Mixed 1 System Pump
- P2 = Mixed 2 System Pump
- P3 = Boiler Pump
- P4 = Variable Speed Injection Pump 1
- P5 = Variable Speed Injection Pump 2
- P6 = DHW Pump
- P7 = H-Temp Pump
- V1 = Floating Action Mixing Valve
- T = Thermostat or Heat Demand

Project:
 Uponor, Inc.
 5925 146th Street W.
 Apple Valley, MN 55124
 Phone: 1-800-321-4739
 Fax: 1-952-891-1409
 www.uponor-usa.com

Drawn by:
 Rep:

Checked by:
 DATE:

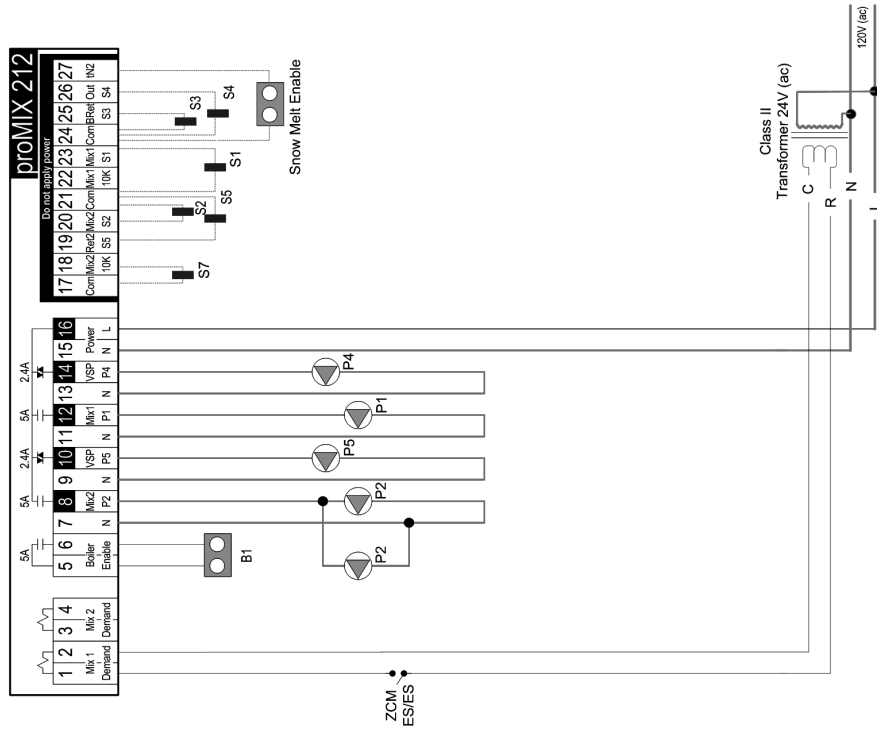

Legend

NOTE: This drawing is conceptual only, not an engineered drawing. It is up to the system designer to determine the necessary components for and the proper installation of the equipment. Isolation relays (for loads greater than the contractor's specified output ratings), and any safety devices which in the judgement of the designer are appropriate. Certain components may have been left out on this drawing for the purpose of clarity. Mechanical considerations such as free spacing, flow control, piping size and trade practices is the responsibility of the installing contractor. Local codes and trade practices must be followed.

- S1 = Mixed 1 Supply Sensor
- S2 = Mixed 2 Supply Sensor
- S3 = Boiler Supply or Return
- S4 = Outdoor Sensor
- S5 = Mixed Return Sensor
- S6 = DHW Sensor
- S7 = Slab Sensor
- S8 = Snow & Ice Detector
- A1 = Aquastat
- B1 = Boiler
- P1 = Mixed 1 System Pump
- P2 = Mixed 2 System Pump
- P3 = Boiler Pump
- P4 = Variable Speed Injection Pump 1
- P5 = Variable Speed Injection Pump 2
- P6 = DHW Pump
- P7 = Hi-Temp Pump
- V1 = Floating Action Mixing Valve
- T = Thermostat or Heat Demand

- = 120 V (AC)
- = Sensor Wire
- = 24 V (AC)
- = T-stat Wire
- = Misc.

Project:	
Uponor, Inc.	Phone: 1-800-321-4739
5925 148th Street W.	Fax: 1-952-891-1409
Apple Valley, MN 55124	www.uponor-usa.com
Drawn by:	Checked by:
Rep:	DATE:

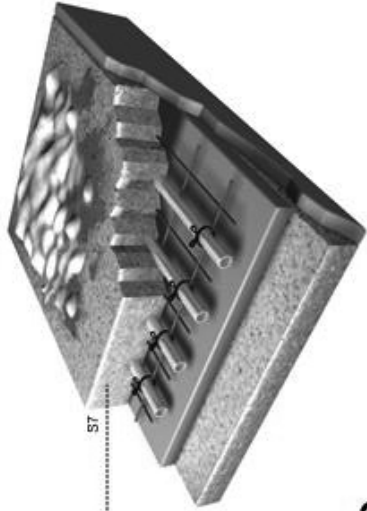
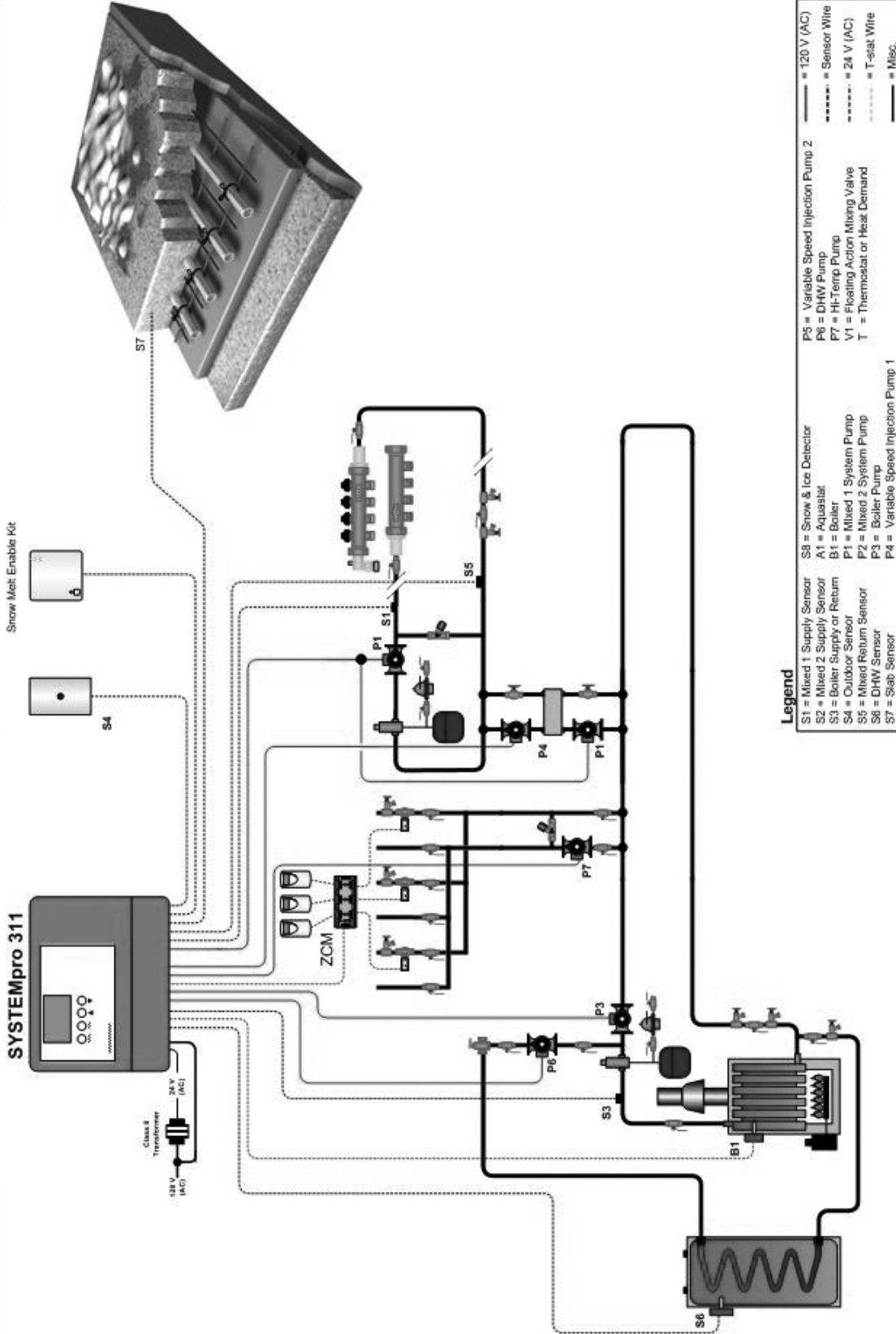

Legend

- S1 = Mixed 1 Supply Sensor
- S2 = Mixed 2 Supply Sensor
- S3 = Boiler Supply or Return
- S4 = Outdoor Sensor
- S5 = Mixed Return Sensor
- S6 = DHW Sensor
- S7 = Stat Sensor
- S8 = Snow & Ice Detector
- A1 = Aquastat
- B1 = Boiler
- P1 = Mixed 1 System Pump
- P2 = Mixed 2 System Pump
- P3 = Boiler Pump
- P4 = Variable Speed Injection Pump 1
- P5 = Variable Speed Injection Pump 2
- P6 = DHW Pump
- P7 = Hi-Temp Pump
- V1 = Floating Action Mixing Valve
- T = Thermostat or Heat Demand
- T-Stat Wire
- Misc.

<p>NOTE: This drawing is conceptual only, not an engineering drawing. It is up to the system designer to determine the necessary components and their interconnections. The designer is responsible for the proper selection, installation, and operation of all components. Mechanical components such as the piping, flow control devices, and valves must be labeled.</p>	<p>Symbols</p>     	<p>Flow Check</p>    	<p>Project: Uponor, Inc. 5925 148th Street West Apple Valley, MN 55124 Phone: (800) 321-4739 Fax: (952) 891-1409 www.uponor-usa.com</p> <p>Drawn by: _____ Checked by: _____ Rep: _____ DATE: _____</p>
---	---	---	---

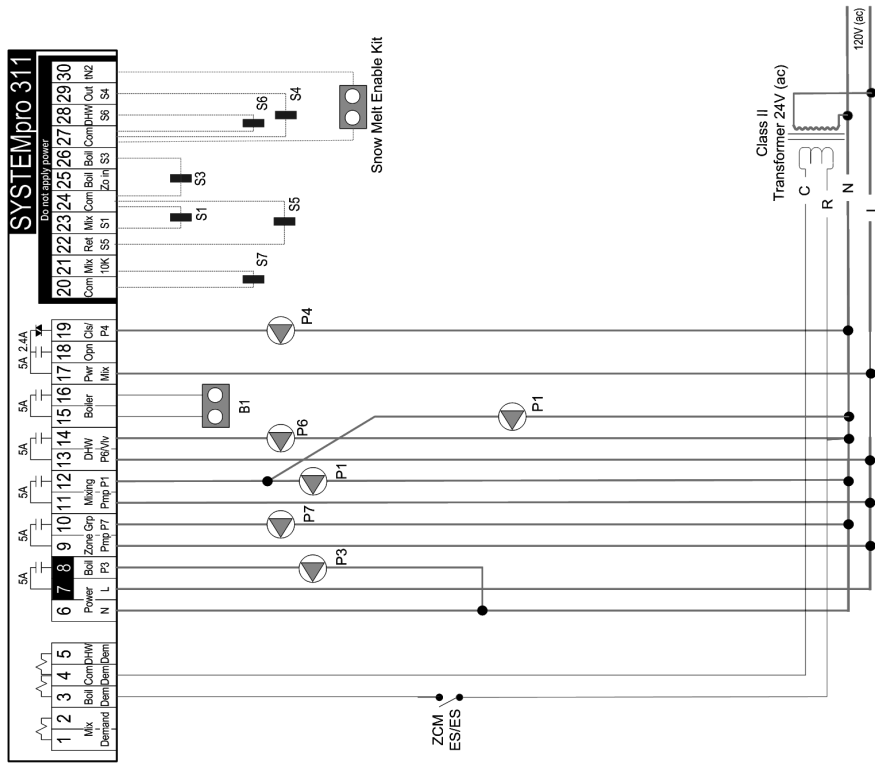

Legend

NOTE: This drawing is conceptual only, not an engineered drawing. It is up to the system designer to determine the necessary components for and equipment ratings (for loads greater than the contractor's specified output ratings), and any safety devices which in the judgement of the designer are appropriate. Certain components may have been left out on this drawing for the purpose of clarity. Mechanical considerations such as tee spacing, flow control, local code and trade practices must be followed.

- S1 = Mixed 1 Supply Sensor
- S2 = Mixed 2 Supply Sensor
- S3 = Boiler Supply or Return
- S4 = Outdoor Sensor
- S5 = Mixed Return Sensor
- S6 = DHW Sensor
- S7 = Slab Sensor
- S8 = Snow & Ice Detector
- A1 = Aquastat
- B1 = Boiler
- P1 = Mixed 1 System Pump
- P2 = Mixed 2 System Pump
- P3 = Boiler Pump
- P4 = Variable Speed Injection Pump 1
- P5 = Variable Speed Injection Pump 2
- P6 = DHW Pump
- P7 = Hi-Temp Pump
- V1 = Floating Action Mixing Valve
- T = Thermostat or Heat Demand

- = 120 V (AC)
- = Sensor Wire
- = 24 V (AC)
- = T-stat Wire
- = Misc.

Project:	
Uponor, Inc.	Phone: 1-800-321-4739
5925 148th Street W.	Fax: 1-952-891-1409
Apple Valley, MN 55124	www.uponor-usa.com
Drawn by:	Checked by:
Rep:	DATE:

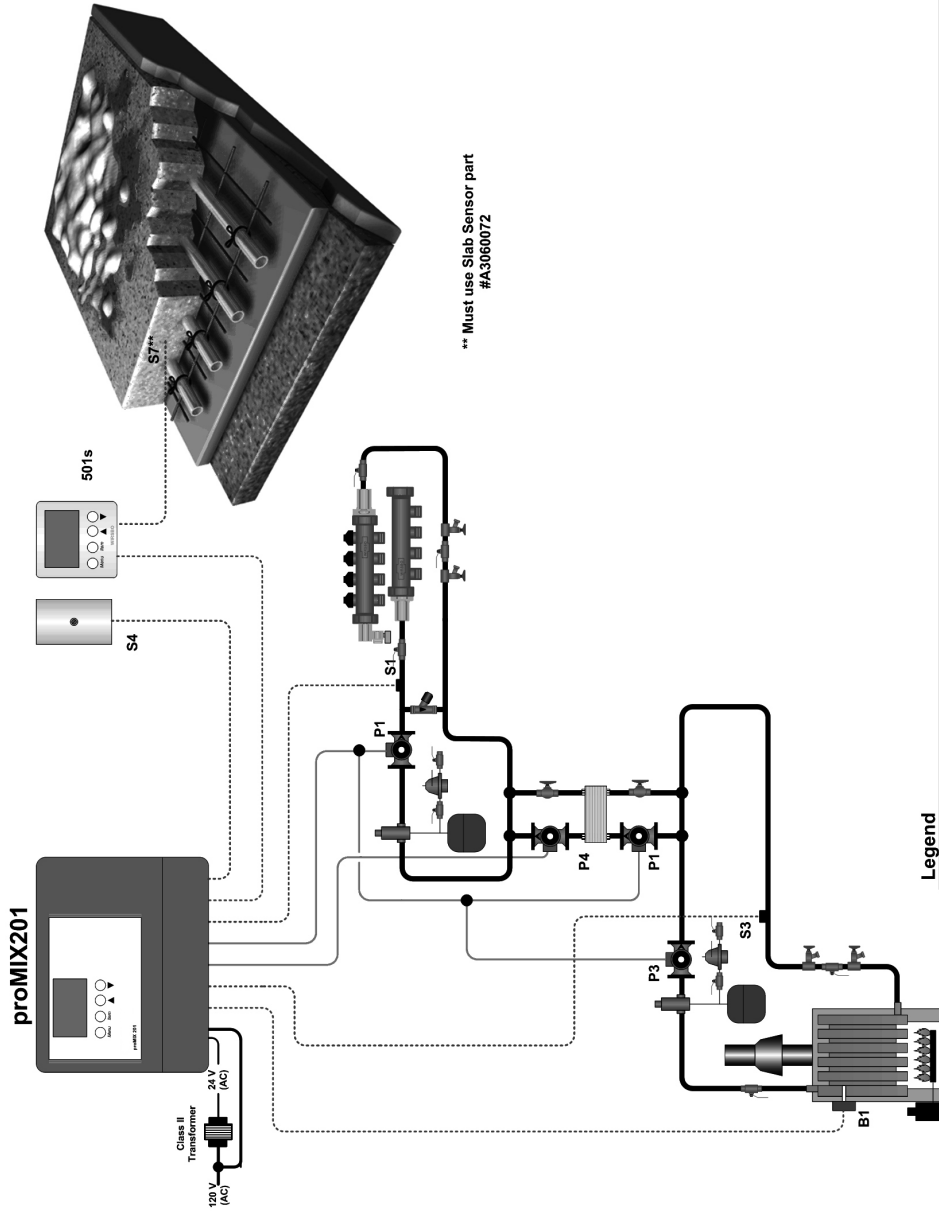

** Must use Slab Sensor part
#A3060072

Legend

- S1 = Mixed 1 Supply Sensor
- S2 = Mixed 2 Supply Sensor
- S3 = Boiler Supply or Return
- S4 = Outdoor Sensor
- S5 = Mixed Return Sensor
- S6 = DHW Sensor
- S7 = Slab Sensor
- S8 = Snow & Ice Detector
- A1 = Aquastat
- B1 = Boiler
- P1 = Mixed 1 System Pump
- P2 = Mixed 2 System Pump
- P3 = Boiler Pump
- P4 = Variable Speed Injection Pump 1
- P5 = Variable Speed Injection Pump 2
- P6 = DHW Pump
- P7 = HI-Temp Pump
- V1 = Floating Action Mixing Valve
- T = Thermostat or Heat Demand
- = 24 V (AC)
- = T-stat Wire
- = Misc.

<p>NOTE: This drawing is conceptual only, not an engineered drawing. It is up to the system designer to determine the necessary components for and the proper installation of the equipment. Isolation relays (for loads greater than the control's specified output ratings), and any safety devices which in the judgement of the designer are appropriate. Certain components may have been left out on this drawing for the purpose of clarity. Mechanical considerations such as tee spacing, flow direction, and pipe size must be followed. Local codes and trade practices must be followed.</p>	<p>Symbols</p> = Floating Action Mixing Valve	= Pump	= Air Separator & Expansion Tank w/ fill	= Zone Valve	= Ball Valve	= Flow Check Valve	<p>Project: Uponor, Inc. 5925 148th Street W. Apple Valley, MN 55124 Phone: 1-800-321-4739 Fax: 1-952-891-1409 www.uponor-usa.com</p>
	= Tempering Valve	= Pressure By-Pass Valve	= Globe Valve	= Drain Valve	<p>Drawn by: _____ Checked by: _____ Rep: _____ DATE: _____</p>		

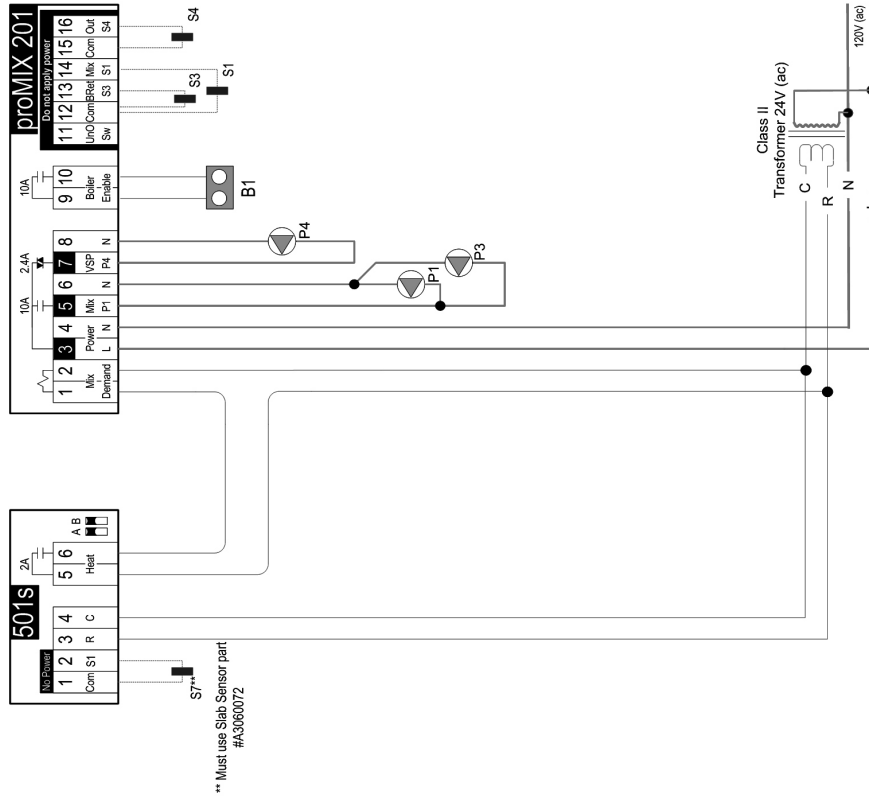

Legend

NOTE: This drawing is conceptual only, not an engineered drawing. It is up to the system designer to determine the necessary components for and coordinate the installation of the equipment. The designer is responsible for equipment, isolation relays (for loads greater than the control's specified output ratings), and any safety devices which in the judgement of the designer are appropriate. Certain components may have been left out on this drawing for the purpose of clarity. Mechanical considerations such as line spacing, flow direction, and the like must be followed. Local codes and trade practices must be followed.

S1 = Mixed 1 Supply Sensor
S2 = Mixed 2 Supply Sensor
S3 = Boiler Supply or Return Sensor
S4 = Outdoor Sensor
S5 = Mixed Return Sensor
S6 = DHW Sensor
S7 = Slab Sensor

S8 = Snow & Ice Detector
A1 = Aquastat
B1 = Boiler
P1 = Mixed 1 System Pump
P2 = Mixed 2 System Pump
P3 = Boiler Pump
P4 = Variable Speed Injection Pump 1

P5 = Variable Speed Injection Pump 2
P6 = DHW Pump
P7 = Hi-Temp Pump
V1 = Floating Action Mixing Valve
T = Thermostat or Heat Demand

Project:
Uponor, Inc.
5925 148th Street W
Apple Valley, MN 55124
Phone: 1-800-321-4739
Fax: 1-952-891-1409
www.uponor-usa.com
Drawn by:
Checked by:
Rep:
DATE:

Appendix A

Design Analysis Worksheet

Project Name: _____ Location: _____

- Step 1a.** Design temperature _____ °F
- Step 1b.** Wind speed _____ mph
- Step 2.** Differential temperature _____ °F
- Step 3.** Surface temperature _____ °F
- Step 4.** BTU/h/ft² load _____ BTU/h/ft²
- Step 5a.** Supply fluid temperature _____ °F
- Step 5b.** Tubing on-center (o.c.) distance _____ inches
- Step 6.** Area in square feet _____ ft²
- Step 7.** Total BTU/h _____ BTU/h
- Step 8a.** Tubing type _____
- Step 8b.** Tubing size _____ inch
- Step 9.** Total amount of tubing _____ feet
- Step 10a.** Active loop length _____ feet
- Step 10b.** Number of loops _____ loops
- Step 11a.** Leader length _____ feet
- Step 11b.** Total loop length _____ feet
- Step 12.** Percentage of glycol _____ %
- Step 13a.** Flow per foot of tubing _____ gpm/ft
- Step 13b.** Flow per loop _____ gpm/loop
- Step 14.** System flow _____ gpm
- Step 15a.** Head pressure drop per foot _____ feet of head
- Step 15b.** Head pressure drop/loop _____ feet of head*

Refer to **Chapter 6** for instructions on how to complete this worksheet.

*The head pressure drop information is used only for the manifold. For proper pump sizing, add the amount of head pressure drop before and after the manifold location to this value.

Appendix B Manifold Worksheet

Project Name: _____ Manifold Number: _____

	Loop 1	Loop 2	Loop 3	Loop 4	Loop 5	Loop 6	Loop 7	Loop 8	Loop 9	Loop 10
A Design temperature (°F)										
B Wind speed (mph)										
C Differential temperature (°F)										
D Surface temperature (°F)										
E BTU/h/ft ²										
F Supply fluid temperature (°F)										
G Tubing o.c. distance										
H Area to be heated (ft ²)										
I Type of tubing										
J Tubing size										
K Active loop length										
L Leader loop length										
M Total loop length										
N Percentage of glycol (%)										
O Flow per foot										
P Flow per loop (gpm)										
Q Head pressure drop/ft (ft of hd)										
R Head pressure drop/loop (ft of hd)										
S Loop balancing turns										

Manifold Totals

T Supply fluid temp. (°F)	
U Manifold flow (gpm)	
V Highest pressure head (ft)	

- A** Select the outdoor design temperature from **Appendix C**.
- B** Select the wind speed in mph from **Appendix C**.
- C** Enter the differential temperature (25°F).
- D** Select the desired surface temperature from **Appendix C**.
- E** Enter the BTU/h/ft² based on the climatic conditions and the surface temperature. Refer to **Appendix C**.
- F** Enter the supply fluid temperature from **Appendix C** based on the climatic conditions and value in row **G**.

- G** Enter the tubing on-center (o.c.) distance.
- H** Enter the square footage of area to be heated by this loop.
- I** Select the type of tubing to be used.
- J** Select the size of tubing to be used.
- K** Multiply the value in row **H** with the appropriate o.c. multiplier (6" = 2.0; 9" = 1.33; 12" = 1.0)
- L** Enter the distance from the slab area to the manifold x 2 (supply and return).
- M** Add rows **K** and **L** together.
- N** Enter the percentage of glycol/water solution to be used.
- O** Using the information in rows **E**, **G** and **N**, go to **Appendix C** and select the flow per foot.
- P** Do not exceed 8 loops per manifold when using the 1 1/4" brass manifold.
- P** Multiply the value in row **K** by the value in row **O**.
- Q** Use the information in rows **F**, **I**, **J**, **N** and **P** with the appropriate Appendix (either **D** or **E**) to obtain the head pressure drop per foot.
- R** Multiply row **M** by the value in row **Q**.
- S** These cells are calculated after the design is completed. Use the balancing information for the respective manifold used as shown in **Chapter 3**.
- T** Enter the highest value from row **F**.
- U** Enter the total of all values from row **P**.
- V** Enter the highest value from row **R**.

Appendix C

System Performance and Flow Charts

This appendix is divided into two sections — Performance Charts and Flow Charts. This page is to assist you in interpreting the charts in order to complete the design.

The snow and ice melting design is based on climatic conditions and a desired slab surface temperature. Enter the Performance Chart at

the appropriate climatic conditions (outdoor temperature and wind speed). Next select the desired slab surface temperature.

These two entries intersect in the cell showing the BTU/h/ft² and supply fluid temperatures for tubing installed at 6, 9 and 12 inches on center.

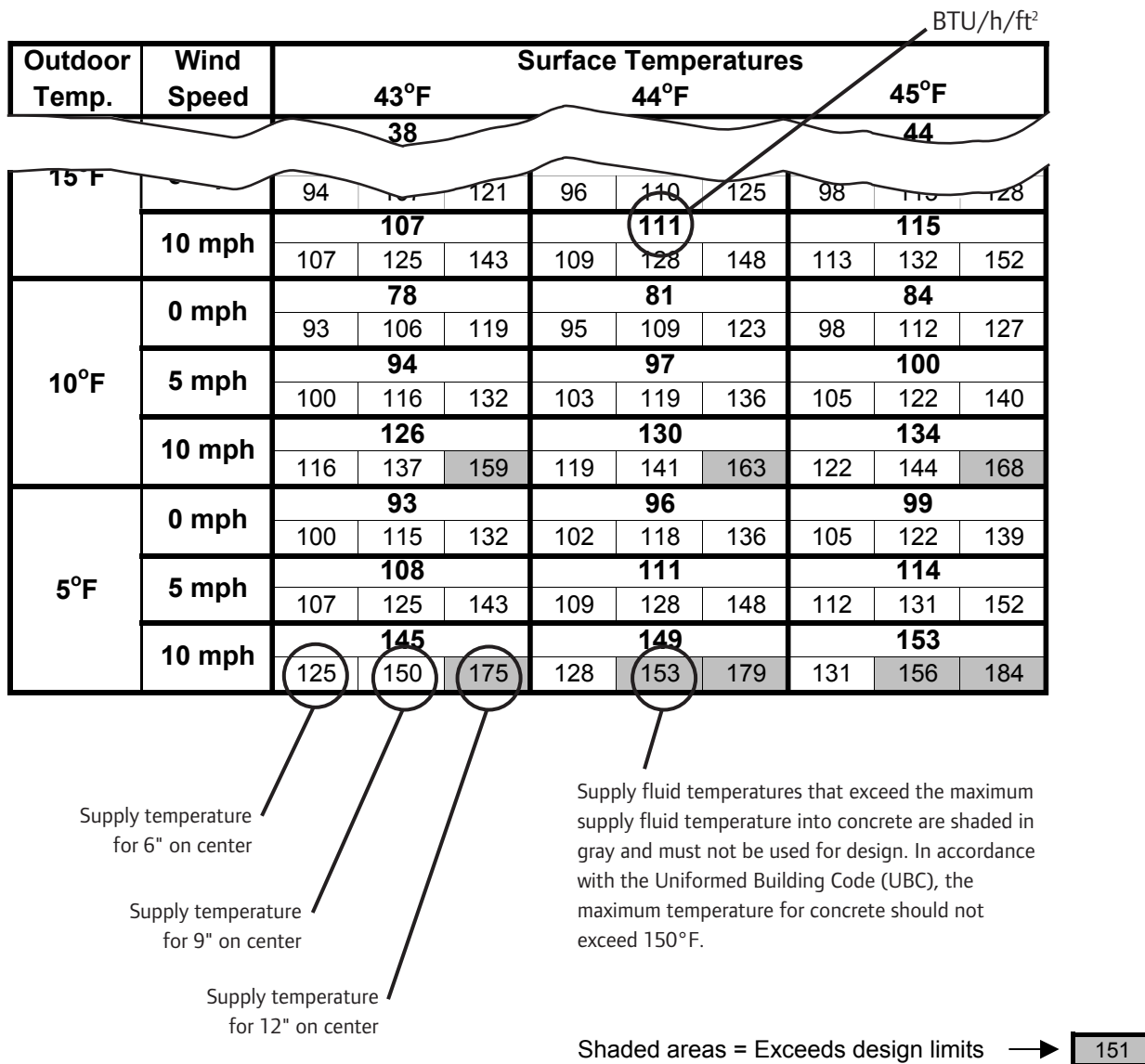

Outdoor Temp.	Wind Speed	Surface Temperatures											
		35°F			36°F			37°F			38°F		
25°F	0 mph	19			21			24			26		
		57	60	63	59	62	66	61	65	70	63	67	73
	5 mph	28			31			34			37		
61		66	71	63	68	75	66	72	79	68	74	82	
10 mph	38			42			46			50			
	66	72	80	69	76	84	72	79	88	74	83	94	
20°F	0 mph	30			33			35			38		
		62	67	73	64	69	76	66	71	79	68	75	81
	5 mph	42			45			48			52		
67		74	83	69	77	85	72	80	89	75	83	93	
10 mph	56			61			64			69			
	74	83	94	77	87	99	79	90	103	83	94	107	
15°F	0 mph	41			45			48			51		
		68	75	81	70	78	86	73	81	89	75	83	93
	5 mph	56			59			62			65		
74		84	94	77	87	97	79	90	100	82	93	104	
10 mph	76			79			84			87			
	84	97	110	87	100	113	90	104	119	92	107	123	
10°F	0 mph	55			58			61			64		
		74	83	93	76	86	96	79	89	100	81	92	103
	5 mph	70			73			76			79		
81		93	106	84	96	108	86	99	112	88	102	116	
10 mph	95			98			103			107			
	93	109	126	96	112	129	99	116	135	102	120	139	
5°F	0 mph	69			72			75			77		
		81	92	105	83	95	108	85	98	111	88	101	115
	5 mph	84			88			90			93		
88		102	117	91	105	121	93	108	124	95	111	127	
10 mph	114			118			121			126			
	102	122	142	105	125	146	108	128	150	111	132	154	
0°F	0 mph	83			86			89			92		
		87	101	116	90	104	120	92	107	122	95	110	126
	5 mph	98			102			104			108		
95		111	129	97	114	133	100	117	135	102	120	139	
10 mph	133			137			141			145			
	112	134	157	114	137	162	117	141	166	120	144	170	
-5°F	0 mph	98			101			104			107		
		95	111	128	97	114	132	99	117	135	102	120	139
	5 mph	113			116			119			122		
102		121	141	104	123	145	107	127	147	109	129	151	
10 mph	152			156			160			165			
	120	146	172	124	150	177	126	153	182	129	156	186	
-10°F	0 mph	113			116			119			123		
		102	121	141	104	124	145	107	127	147	110	130	151
	5 mph	127			130			133			136		
109		130	152	111	133	156	114	136	159	116	139	162	
10 mph	172			175			180			183			
	130	159	190	133	162	194	136	166	198	139	169	202	

Shaded areas = Exceeds design limits → 151

Surface Temperatures												Wind Speed	Outdoor Temp.	
39°F			40°F			41°F			42°F					
28			31			33			36			0 mph	25°F	
65	70	76	67	72	79	70	75	82	72	78	85			
40			43			46			49					
71	77	85	73	80	90	76	83	92	78	86	95	5 mph		
53			57			61			65					
77	86	96	80	89	100	83	93	104	86	97	109	10 mph		
40			44			46			49			0 mph		20°F
70	77	84	73	80	88	75	82	90	77	85	94			
54			57			62			64					
76	85	95	80	88	99	83	94	105	84	95	106	5 mph		
72			77			84			86					
85	97	111	89	101	115	93	107	123	94	108	123	10 mph		
53			56			59			61			0 mph	15°F	
77	86	95	79	89	97	82	91	102	84	94	104			
68			71			74			77					
84	95	107	87	99	112	89	101	115	91	104	117	5 mph		
91			95			99			103					
95	110	126	98	114	131	101	118	135	104	121	140	10 mph		
67			69			73			75			0 mph		10°F
84	95	107	86	97	110	88	101	113	91	103	117			
82			85			88			91					
91	105	120	93	108	123	96	111	126	98	113	130	5 mph		
110			115			118			122					
104	123	143	107	127	147	110	130	151	113	133	155	10 mph		
81			83			87			90			0 mph	5°F	
90	104	118	92	106	123	95	110	125	98	113	127			
96			99			102			105					
98	114	130	100	117	134	102	120	138	105	122	140	5 mph		
129			134			137			141					
114	135	158	117	139	164	119	143	167	122	146	171	10 mph		
95			98			101			104			0 mph		0°F
97	113	128	100	116	132	102	119	136	104	122	139			
110			113			116			119					
104	123	141	107	126	145	109	129	149	112	132	153	5 mph		
149			152			157			160					
123	148	174	126	151	179	129	155	182	131	158	187	10 mph		
110			113			116			119			0 mph	-5°F	
104	123	141	107	126	145	109	129	149	112	132	152			
125			127			131			133					
111	132	153	114	135	157	116	138	161	118	141	163	5 mph		
168			172			176			180					
132	160	190	135	164	194	138	167	198	141	171	202	10 mph		
126			129			132			135			0 mph		-10°F
112	133	154	114	136	158	117	139	162	120	142	165			
139			142			145			148					
119	142	166	121	145	168	123	148	173	126	150	176	5 mph		
187			191			195			199					
141	173	206	144	177	211	147	180	214	150	183	219	10 mph		

Shaded areas = Exceeds design limits → 151

Outdoor Temp.	Wind Speed	Surface Temperatures								
		43°F			44°F			45°F		
25°F	0 mph	38			41			44		
		74	80	86	76	83	91	78	86	94
	5 mph	52			55			58		
		80	89	99	82	92	102	85	95	106
10 mph	69			73			77			
		88	100	113	91	104	118	95	108	212
20°F	0 mph	52			55			57		
		80	89	99	82	91	102	83	93	104
	5 mph	66			69			72		
		86	97	110	88	100	113	91	103	117
10 mph	88			91			96			
		96	110	128	98	114	131	103	120	137
15°F	0 mph	65			67			70		
		86	97	109	89	100	111	91	103	114
	5 mph	80			83			86		
		94	107	121	96	110	125	98	113	128
10 mph	107			111			115			
		107	125	143	109	128	148	113	132	152
10°F	0 mph	78			81			84		
		93	106	119	95	109	123	98	112	127
	5 mph	94			97			100		
		100	116	132	103	119	136	105	122	140
10 mph	126			130			134			
		116	137	159	119	141	163	122	144	168
5°F	0 mph	93			96			99		
		100	115	132	102	118	136	105	122	139
	5 mph	108			111			114		
		107	125	143	109	128	148	112	131	152
10 mph	145			149			153			
		125	150	175	128	153	179	131	156	184
0°F	0 mph	108			111			114		
		107	125	145	110	128	147	112	131	151
	5 mph	122			125			128		
		114	134	157	117	138	160	119	140	163
10 mph	166			168			172			
		134	162	193	137	166	196	140	169	201
-5°F	0 mph	123			126			129		
		114	135	157	117	138	157	119	141	164
	5 mph	137			139			143		
		121	144	168	123	147	171	126	150	174
10 mph	183			188			191			
		143	174	207	146	178	212	149	181	216
-10°F	0 mph	138			142			145		
		122	145	169	125	142	174	128	152	177
	5 mph	151			154			157		
		129	154	181	130	156	183	133	159	169
10 mph	203			207			211			
		153	187	224	156	190	228	159	194	231

Shaded areas = Exceeds design limits → 151

Flow Per Foot of Active Loop Length

Glycol Percentage									Load In BTU/h/ft ²
30% Glycol			40% Glycol			50% Glycol			
6" o.c.	9" o.c.	12" o.c.	6" o.c.	9" o.c.	12" o.c.	6" o.c.	9" o.c.	12" o.c.	
0.0008	0.0012	0.0017	0.0009	0.0013	0.0017	0.0009	0.0014	0.0018	20
0.0009	0.0014	0.0018	0.0009	0.0014	0.0019	0.0010	0.0015	0.0020	22
0.0010	0.0015	0.0020	0.0010	0.0015	0.0021	0.0011	0.0017	0.0022	24
0.0011	0.0016	0.0022	0.0011	0.0017	0.0022	0.0012	0.0018	0.0024	26
0.0012	0.0017	0.0023	0.0012	0.0018	0.0024	0.0013	0.0019	0.0026	28
0.0012	0.0019	0.0025	0.0013	0.0019	0.0026	0.0014	0.0021	0.0028	30
0.0013	0.0020	0.0027	0.0014	0.0021	0.0027	0.0015	0.0022	0.0029	32
0.0014	0.0021	0.0028	0.0015	0.0022	0.0029	0.0016	0.0023	0.0031	34
0.0015	0.0022	0.0030	0.0015	0.0023	0.0031	0.0017	0.0025	0.0033	36
0.0016	0.0024	0.0032	0.0016	0.0024	0.0033	0.0017	0.0026	0.0035	38
0.0017	0.0025	0.0033	0.0017	0.0026	0.0034	0.0018	0.0028	0.0037	40
0.0017	0.0026	0.0035	0.0018	0.0027	0.0036	0.0019	0.0029	0.0039	42
0.0018	0.0027	0.0037	0.0019	0.0028	0.0038	0.0020	0.0030	0.0040	44
0.0019	0.0029	0.0038	0.0020	0.0030	0.0039	0.0021	0.0032	0.0042	46
0.0020	0.0030	0.0040	0.0021	0.0031	0.0041	0.0022	0.0033	0.0044	48
0.0021	0.0031	0.0042	0.0021	0.0032	0.0043	0.0023	0.0034	0.0046	50
0.0022	0.0032	0.0043	0.0022	0.0033	0.0045	0.0024	0.0036	0.0048	52
0.0022	0.0034	0.0045	0.0023	0.0035	0.0046	0.0025	0.0037	0.0050	54
0.0023	0.0035	0.0047	0.0024	0.0036	0.0048	0.0026	0.0039	0.0051	56
0.0024	0.0036	0.0048	0.0025	0.0037	0.0050	0.0027	0.0040	0.0053	58
0.0025	0.0037	0.0050	0.0026	0.0039	0.0051	0.0028	0.0041	0.0055	60
0.0026	0.0039	0.0052	0.0027	0.0040	0.0053	0.0028	0.0043	0.0057	62
0.0027	0.0040	0.0053	0.0027	0.0041	0.0055	0.0029	0.0044	0.0059	64
0.0027	0.0041	0.0055	0.0028	0.0042	0.0057	0.0030	0.0045	0.0061	66
0.0028	0.0042	0.0057	0.0029	0.0044	0.0058	0.0031	0.0047	0.0062	68
0.0029	0.0044	0.0058	0.0030	0.0045	0.0060	0.0032	0.0048	0.0064	70
0.0030	0.0045	0.0060	0.0031	0.0046	0.0062	0.0033	0.0050	0.0066	72
0.0031	0.0046	0.0062	0.0032	0.0048	0.0063	0.0034	0.0051	0.0068	74
0.0032	0.0047	0.0063	0.0033	0.0049	0.0065	0.0035	0.0052	0.0070	76
0.0032	0.0049	0.0065	0.0033	0.0050	0.0067	0.0036	0.0054	0.0072	78
0.0033	0.0050	0.0067	0.0034	0.0051	0.0069	0.0037	0.0055	0.0073	80
0.0034	0.0051	0.0068	0.0035	0.0053	0.0070	0.0038	0.0056	0.0075	82
0.0035	0.0052	0.0070	0.0036	0.0054	0.0072	0.0039	0.0058	0.0077	84
0.0036	0.0054	0.0072	0.0037	0.0055	0.0074	0.0039	0.0059	0.0079	86
0.0037	0.0055	0.0073	0.0038	0.0057	0.0075	0.0040	0.0061	0.0081	88
0.0037	0.0056	0.0075	0.0039	0.0058	0.0077	0.0041	0.0062	0.0083	90
0.0038	0.0057	0.0077	0.0039	0.0059	0.0079	0.0042	0.0063	0.0084	92
0.0039	0.0059	0.0078	0.0040	0.0060	0.0081	0.0043	0.0065	0.0086	94
0.0040	0.0060	0.0080	0.0041	0.0062	0.0082	0.0044	0.0066	0.0088	96
0.0041	0.0061	0.0082	0.0042	0.0063	0.0084	0.0045	0.0068	0.0090	98

To calculate flow for a given loop:

1. Select the BTU/h/ft² load that was determined from the Performance Charts in this Appendix.
2. Select the percentage of glycol mix in the snow and ice melting system.
3. Within the glycol percentage column, select the on-center (o.c.) distance for the installed tubing.
4. Move horizontally from the BTU/h/ft² load toward the applicable o.c. column.
5. Where these lines intersect is the flow per foot of active loop.
6. Multiply the flow per loop value by the length of active loop within the total loop to obtain the flow for the loop.

Example:

1. A snow and ice melting system designed for 0°F with a 10-mph wind with a 38°F surface temperature. The load is 145 BTU/h/ft².
2. Enter the flow charts at 146 BTU/h/ft² (round up from 145 in step 1). Then move across to the 40% glycol with the tubing at 9" o.c.
3. Flow per foot is 0.0094 gpm. If the active loop is 200' of a total loop of 245', multiply 0.0094 by 200 = 1.88 gpm per loop.

Flow Per Foot of Active Loop Length

Load In BTU/h/ft ²	Glycol Percentage								
	30% Glycol			40% Glycol			50% Glycol		
	6" o.c.	9" o.c.	12" o.c.	6" o.c.	9" o.c.	12" o.c.	6" o.c.	9" o.c.	12" o.c.
100	0.0042	0.0062	0.0083	0.0043	0.0064	0.0086	0.0046	0.0069	0.0092
102	0.0042	0.0064	0.0085	0.0044	0.0066	0.0087	0.0047	0.0070	0.0094
104	0.0043	0.0065	0.0087	0.0045	0.0067	0.0089	0.0048	0.0072	0.0096
106	0.0044	0.0066	0.0088	0.0045	0.0068	0.0091	0.0049	0.0073	0.0097
108	0.0045	0.0067	0.0090	0.0046	0.0069	0.0092	0.0050	0.0074	0.0099
110	0.0046	0.0069	0.0092	0.0047	0.0071	0.0094	0.0051	0.0076	0.0101
112	0.0047	0.0070	0.0093	0.0048	0.0072	0.0096	0.0051	0.0077	0.0103
114	0.0047	0.0071	0.0095	0.0049	0.0073	0.0098	0.0052	0.0079	0.0105
116	0.0048	0.0072	0.0097	0.0050	0.0075	0.0099	0.0053	0.0080	0.0107
118	0.0049	0.0074	0.0098	0.0051	0.0076	0.0101	0.0054	0.0081	0.0108
120	0.0050	0.0075	0.0100	0.0051	0.0077	0.0103	0.0055	0.0083	0.0110
122	0.0051	0.0076	0.0102	0.0052	0.0078	0.0104	0.0056	0.0084	0.0112
124	0.0052	0.0077	0.0103	0.0053	0.0080	0.0106	0.0057	0.0085	0.0114
126	0.0052	0.0079	0.0105	0.0054	0.0081	0.0108	0.0058	0.0087	0.0116
128	0.0053	0.0080	0.0107	0.0055	0.0082	0.0110	0.0059	0.0088	0.0118
130	0.0054	0.0081	0.0108	0.0056	0.0083	0.0111	0.0060	0.0090	0.0119
132	0.0055	0.0082	0.0110	0.0057	0.0085	0.0113	0.0061	0.0091	0.0121
134	0.0056	0.0084	0.0112	0.0057	0.0086	0.0115	0.0062	0.0092	0.0123
136	0.0057	0.0085	0.0113	0.0058	0.0087	0.0116	0.0062	0.0094	0.0125
138	0.0058	0.0087	0.0116	0.0060	0.0089	0.0119	0.0064	0.0096	0.0128
140	0.0058	0.0087	0.0117	0.0060	0.0090	0.0120	0.0064	0.0096	0.0129
142	0.0059	0.0089	0.0118	0.0061	0.0091	0.0122	0.0065	0.0098	0.0130
144	0.0060	0.0090	0.0120	0.0062	0.0092	0.0123	0.0066	0.0099	0.0132
146	0.0061	0.0091	0.0122	0.0063	0.0094	0.0125	0.0067	0.0101	0.0134
148	0.0062	0.0092	0.0123	0.0063	0.0095	0.0127	0.0068	0.0102	0.0136
150	0.0062	0.0094	0.0125	0.0064	0.0096	0.0128	0.0069	0.0103	0.0138
152	0.0063	0.0095	0.0127	0.0065	0.0098	0.0130	0.0070	0.0105	0.0140
154	0.0064	0.0096	0.0128	0.0066	0.0099	0.0132	0.0071	0.0106	0.0141
156	0.0065	0.0097	0.0130	0.0067	0.0100	0.0134	0.0072	0.0107	0.0143
158	0.0066	0.0099	0.0132	0.0068	0.0101	0.0135	0.0073	0.0109	0.0145
160	0.0067	0.0100	0.0133	0.0069	0.0103	0.0137	0.0073	0.0110	0.0147
162	0.0067	0.0101	0.0135	0.0069	0.0104	0.0139	0.0074	0.0112	0.0149
164	0.0068	0.0102	0.0137	0.0070	0.0105	0.0140	0.0075	0.0113	0.0151
166	0.0069	0.0104	0.0138	0.0071	0.0107	0.0142	0.0076	0.0114	0.0152
168	0.0070	0.0105	0.0140	0.0072	0.0108	0.0144	0.0077	0.0116	0.0154
170	0.0071	0.0106	0.0142	0.0073	0.0109	0.0146	0.0078	0.0117	0.0156
172	0.0072	0.0107	0.0143	0.0074	0.0110	0.0147	0.0079	0.0118	0.0158
174	0.0072	0.0109	0.0145	0.0075	0.0112	0.0149	0.0080	0.0120	0.0160
176	0.0073	0.0110	0.0147	0.0075	0.0113	0.0151	0.0081	0.0121	0.0162
178	0.0074	0.0111	0.0148	0.0076	0.0114	0.0152	0.0082	0.0123	0.0163

Flow Per Foot of Active Loop Length

Glycol Percentage									Load In BTU/h/ft ²
30% Glycol			40% Glycol			50% Glycol			
6" o.c.	9" o.c.	12" o.c.	6" o.c.	9" o.c.	12" o.c.	6" o.c.	9" o.c.	12" o.c.	
0.0075	0.0112	0.0150	0.0077	0.0116	0.0154	0.0083	0.0124	0.0165	180
0.0076	0.0114	0.0152	0.0078	0.0117	0.0156	0.0084	0.0125	0.0167	182
0.0077	0.0115	0.0153	0.0079	0.0118	0.0158	0.0084	0.0127	0.0169	184
0.0077	0.0116	0.0155	0.0080	0.0119	0.0159	0.0085	0.0128	0.0171	186
0.0078	0.0117	0.0157	0.0081	0.0121	0.0161	0.0086	0.0129	0.0173	188
0.0079	0.0119	0.0158	0.0081	0.0122	0.0163	0.0087	0.0131	0.0174	190
0.0080	0.0120	0.0160	0.0082	0.0123	0.0164	0.0088	0.0132	0.0176	192
0.0081	0.0121	0.0162	0.0083	0.0125	0.0166	0.0089	0.0134	0.0178	194
0.0082	0.0122	0.0163	0.0084	0.0126	0.0168	0.0090	0.0135	0.0180	196
0.0082	0.0124	0.0165	0.0085	0.0127	0.0170	0.0091	0.0136	0.0182	198
0.0083	0.0125	0.0167	0.0086	0.0128	0.0171	0.0092	0.0138	0.0184	200
0.0084	0.0126	0.0168	0.0086	0.0130	0.0173	0.0093	0.0139	0.0186	202
0.0085	0.0127	0.0170	0.0087	0.0131	0.0175	0.0094	0.0141	0.0187	204
0.0086	0.0129	0.0172	0.0088	0.0132	0.0176	0.0095	0.0142	0.0189	206
0.0087	0.0130	0.0173	0.0089	0.0134	0.0178	0.0096	0.0143	0.0191	208
0.0087	0.0131	0.0175	0.0090	0.0135	0.0180	0.0096	0.0145	0.0193	210
0.0088	0.0132	0.0177	0.0091	0.0136	0.0182	0.0097	0.0146	0.0195	212
0.0089	0.0134	0.0178	0.0092	0.0137	0.0183	0.0098	0.0147	0.0197	214
0.0090	0.0135	0.0180	0.0092	0.0139	0.0185	0.0099	0.0149	0.0198	216
0.0091	0.0136	0.0182	0.0093	0.0140	0.0187	0.0100	0.0150	0.0200	218
0.0092	0.0137	0.0183	0.0094	0.0141	0.0188	0.0101	0.0152	0.0202	220
0.0092	0.0139	0.0185	0.0095	0.0143	0.0190	0.0102	0.0153	0.0204	222
0.0093	0.0140	0.0187	0.0096	0.0144	0.0192	0.0103	0.0154	0.0206	224
0.0094	0.0141	0.0188	0.0097	0.0145	0.0194	0.0104	0.0156	0.0208	226
0.0095	0.0142	0.0190	0.0098	0.0146	0.0195	0.0105	0.0157	0.0209	228
0.0096	0.0144	0.0192	0.0098	0.0148	0.0197	0.0106	0.0158	0.0211	230
0.0097	0.0145	0.0193	0.0099	0.0149	0.0199	0.0107	0.0160	0.0213	232
0.0097	0.0146	0.0195	0.0100	0.0150	0.0200	0.0107	0.0161	0.0215	234
0.0098	0.0147	0.0197	0.0101	0.0152	0.0202	0.0108	0.0163	0.0217	236
0.0099	0.0149	0.0198	0.0102	0.0153	0.0204	0.0109	0.0164	0.0219	238
0.0100	0.0150	0.0200	0.0103	0.0154	0.0206	0.0110	0.0165	0.0220	240
0.0101	0.0151	0.0202	0.0104	0.0155	0.0207	0.0111	0.0167	0.0222	242
0.0102	0.0152	0.0203	0.0104	0.0157	0.0209	0.0112	0.0168	0.0224	244
0.0102	0.0154	0.0205	0.0105	0.0158	0.0211	0.0113	0.0169	0.0226	246
0.0103	0.0155	0.0207	0.0106	0.0159	0.0212	0.0114	0.0171	0.0228	248
0.0104	0.0156	0.0208	0.0107	0.0161	0.0214	0.0115	0.0172	0.0230	250
0.0105	0.0157	0.0210	0.0108	0.0162	0.0216	0.0116	0.0174	0.0231	252
0.0106	0.0159	0.0212	0.0109	0.0163	0.0218	0.0117	0.0175	0.0233	254
0.0107	0.0160	0.0213	0.0110	0.0164	0.0219	0.0118	0.0176	0.0235	256
0.0107	0.0161	0.0215	0.0110	0.0166	0.0221	0.0118	0.0178	0.0237	258

Appendix D

Uponor PEX-a Hydronic Friction Loss Tables

5/16" Uponor PEX-a — 100% Water — Feet of Head per Foot of Tubing

Velocity (ft./sec.)	GPM	80°F 27°C	90°F 32°C	100°F 38°C	110°F 43°C	120°F 49°C	130°F 54°C	140°F 60°C	150°F 66°C	160°F 71°C	170°F 77°C	180°F 82°C	190°F 88°C	200°F 93°C
0.5	0.10	0.00908	0.00873	0.00841	0.00814	0.00789	0.00767	0.00747	0.00729	0.00712	0.00697	0.00683	0.00670	0.00659
0.6	0.13	0.01230	0.01183	0.01141	0.01105	0.01072	0.01043	0.01016	0.00992	0.00970	0.00950	0.00931	0.00914	0.00899
0.7	0.15	0.01591	0.01531	0.01479	0.01433	0.01391	0.01354	0.01320	0.01289	0.01261	0.01235	0.01212	0.01190	0.01170
0.8	0.17	0.01990	0.01917	0.01852	0.01795	0.01744	0.01698	0.01657	0.01619	0.01584	0.01552	0.01523	0.01496	0.01471
0.9	0.19	0.02426	0.02338	0.02261	0.02192	0.02131	0.02075	0.02025	0.01979	0.01938	0.01899	0.01864	0.01832	0.01802
1.0	0.21	0.02898	0.02795	0.02703	0.02622	0.02550	0.02484	0.02425	0.02371	0.02322	0.02276	0.02235	0.02197	0.02161
1.1	0.23	0.03405	0.03285	0.03179	0.03085	0.03000	0.02924	0.02856	0.02793	0.02735	0.02682	0.02634	0.02589	0.02548
1.2	0.25	0.03946	0.03808	0.03687	0.03579	0.03482	0.03395	0.03316	0.03243	0.03178	0.03116	0.03061	0.03010	0.02962
1.3	0.27	0.04520	0.04364	0.04226	0.04104	0.03994	0.03895	0.03805	0.03723	0.03648	0.03579	0.03516	0.03458	0.03404
1.4	0.29	0.05127	0.04952	0.04797	0.04660	0.04536	0.04424	0.04324	0.04231	0.04147	0.04068	0.03998	0.03932	0.03871
1.5	0.31	0.05767	0.05572	0.05399	0.05246	0.05107	0.04983	0.04870	0.04767	0.04673	0.04585	0.04506	0.04433	0.04365
1.6	0.33	0.06438	0.06222	0.06031	0.05861	0.05707	0.05569	0.05445	0.05330	0.05226	0.05128	0.05041	0.04959	0.04884
1.7	0.35	0.07141	0.06903	0.06692	0.06505	0.06336	0.06184	0.06047	0.05920	0.05805	0.05698	0.05601	0.05512	0.05428
1.8	0.38	0.07874	0.07614	0.07383	0.07178	0.06993	0.06826	0.06676	0.06537	0.06411	0.06293	0.06187	0.06089	0.05997
1.9	0.40	0.08638	0.08355	0.08103	0.07880	0.07678	0.07496	0.07332	0.07180	0.07043	0.06914	0.06799	0.06692	0.06592
2.0	0.42	0.09433	0.09125	0.08852	0.08609	0.08390	0.08193	0.08014	0.07850	0.07701	0.07561	0.07435	0.07319	0.07210
2.1	0.44	0.10257	0.09924	0.09629	0.09367	0.09130	0.08916	0.08723	0.08545	0.08384	0.08233	0.08097	0.07970	0.07853
2.2	0.46	0.11110	0.10752	0.10434	0.10152	0.09896	0.09666	0.09458	0.09266	0.09092	0.08929	0.08782	0.08646	0.08519
2.3	0.48	0.11993	0.11609	0.11267	0.10964	0.10689	0.10442	0.10219	0.10013	0.09826	0.09650	0.09493	0.09346	0.09210
2.4	0.50	0.12905	0.12494	0.12128	0.11803	0.11509	0.11244	0.11005	0.10784	0.10584	0.10396	0.10227	0.10070	0.09924
2.5	0.52	0.13845	0.13406	0.13015	0.12669	0.12355	0.12072	0.11816	0.11580	0.11367	0.11165	0.10985	0.10817	0.10661
2.6	0.54	0.14814	0.14346	0.13930	0.13561	0.13226	0.12925	0.12653	0.12401	0.12174	0.11959	0.11767	0.11588	0.11422
2.7	0.56	0.15811	0.15314	0.14872	0.14480	0.14124	0.13804	0.13514	0.13247	0.13005	0.12777	0.12572	0.12382	0.12205
2.8	0.58	0.16836	0.16309	0.15841	0.15424	0.15047	0.14708	0.14400	0.14117	0.13860	0.13618	0.13401	0.13199	0.13011
2.9	0.61	0.17888	0.17331	0.16835	0.16395	0.15996	0.15636	0.15311	0.15011	0.14739	0.14483	0.14253	0.14039	0.13840
3.0	0.63	0.18968	0.18380	0.17856	0.17391	0.16970	0.16590	0.16246	0.15929	0.15641	0.15371	0.15128	0.14902	0.14692
3.1	0.65	0.20076	0.19456	0.18904	0.18413	0.17968	0.17568	0.17205	0.16871	0.16568	0.16282	0.16026	0.15788	0.15566
3.2	0.67	0.21210	0.20558	0.19977	0.19460	0.18992	0.18571	0.18189	0.17837	0.17517	0.17217	0.16947	0.16696	0.16462
3.3	0.69	0.22372	0.21686	0.21075	0.20533	0.20041	0.19597	0.19196	0.18826	0.18490	0.18174	0.17890	0.17626	0.17380
3.4	0.71	0.23560	0.22841	0.22200	0.21630	0.21114	0.20648	0.20227	0.19838	0.19486	0.19154	0.18856	0.18579	0.18320

Recommended Head Loss Design Range

Sizing in this region will lead to excessive head loss conditions.

Appendix D

Uponor PEX-a Hydronic Friction Loss Tables

5/16" Uponor PEX-a — 30% Propylene Glycol — Feet of Head per Foot of Tubing

Velocity (ft./sec.)	GPM	80°F 27°C	90°F 32°C	100°F 38°C	110°F 43°C	120°F 49°C	130°F 54°C	140°F 60°C	150°F 66°C	160°F 71°C	170°F 77°C	180°F 82°C	190°F 88°C	200°F 93°C
0.5	0.10	0.01318	0.01231	0.01159	0.01096	0.01044	0.00998	0.00957	0.00924	0.00893	0.00864	0.00840	0.00817	0.00800
0.6	0.13	0.01767	0.01654	0.01559	0.01477	0.01409	0.01348	0.01294	0.01251	0.01209	0.01171	0.01140	0.01109	0.01087
0.7	0.15	0.02268	0.02126	0.02007	0.01903	0.01817	0.01741	0.01672	0.01618	0.01565	0.01517	0.01477	0.01438	0.01410
0.8	0.17	0.02819	0.02646	0.02499	0.02373	0.02267	0.02174	0.02090	0.02023	0.01958	0.01899	0.01850	0.01803	0.01767
0.9	0.19	0.03417	0.03211	0.03036	0.02885	0.02759	0.02647	0.02546	0.02466	0.02388	0.02317	0.02258	0.02201	0.02159
1.0	0.21	0.04061	0.03820	0.03615	0.03438	0.03289	0.03157	0.03039	0.02945	0.02853	0.02769	0.02700	0.02632	0.02583
1.1	0.23	0.04750	0.04472	0.04235	0.04030	0.03858	0.03706	0.03568	0.03459	0.03353	0.03256	0.03175	0.03096	0.03038
1.2	0.25	0.05483	0.05165	0.04895	0.04661	0.04465	0.04290	0.04133	0.04008	0.03886	0.03775	0.03683	0.03592	0.03526
1.3	0.27	0.06259	0.05900	0.05595	0.05330	0.05108	0.04910	0.04732	0.04590	0.04452	0.04326	0.04222	0.04119	0.04044
1.4	0.29	0.07077	0.06675	0.06333	0.06037	0.05787	0.05566	0.05365	0.05206	0.05051	0.04910	0.04792	0.04677	0.04592
1.5	0.31	0.07936	0.07490	0.07110	0.06780	0.06502	0.06255	0.06032	0.05855	0.05682	0.05524	0.05393	0.05264	0.05170
1.6	0.33	0.08836	0.08343	0.07923	0.07559	0.07252	0.06979	0.06732	0.06536	0.06344	0.06169	0.06024	0.05882	0.05777
1.7	0.35	0.09776	0.09235	0.08773	0.08373	0.08036	0.07735	0.07464	0.07248	0.07038	0.06845	0.06685	0.06528	0.06412
1.8	0.38	0.10754	0.10164	0.09660	0.09222	0.08853	0.08525	0.08228	0.07992	0.07761	0.07551	0.07376	0.07204	0.07077
1.9	0.40	0.11772	0.11130	0.10582	0.10106	0.09705	0.09347	0.09024	0.08766	0.08515	0.08286	0.08095	0.07907	0.07769
2.0	0.42	0.12827	0.12133	0.11539	0.11024	0.10589	0.10201	0.09851	0.09572	0.09299	0.09050	0.08843	0.08639	0.08489
2.1	0.44	0.13921	0.13172	0.12532	0.11975	0.11506	0.11087	0.10709	0.10407	0.10113	0.09843	0.09619	0.09399	0.09237
2.2	0.46	0.15051	0.14246	0.13558	0.12960	0.12455	0.12004	0.11597	0.11272	0.10955	0.10665	0.10424	0.10187	0.10012
2.3	0.48	0.16219	0.15356	0.14619	0.13977	0.13435	0.12952	0.12515	0.12167	0.11826	0.11515	0.11256	0.11001	0.10813
2.4	0.50	0.17423	0.16501	0.15713	0.15027	0.14448	0.13931	0.13463	0.13090	0.12726	0.12393	0.12116	0.11843	0.11642
2.5	0.52	0.18663	0.17681	0.16841	0.16109	0.15492	0.14940	0.14441	0.14043	0.13655	0.13299	0.13003	0.12711	0.12497
2.6	0.54	0.19938	0.18895	0.18002	0.17223	0.16566	0.15980	0.15449	0.15025	0.14611	0.14232	0.13917	0.13607	0.13378
2.7	0.56	0.21249	0.20143	0.19195	0.18369	0.17672	0.17049	0.16485	0.16035	0.15595	0.15192	0.14858	0.14528	0.14285
2.8	0.58	0.22596	0.21424	0.20421	0.19547	0.18808	0.18148	0.17550	0.17073	0.16607	0.16180	0.15825	0.15476	0.15218
2.9	0.61	0.23977	0.22739	0.21679	0.20755	0.19974	0.19276	0.18644	0.18139	0.17647	0.17195	0.16819	0.16449	0.16176

Recommended Head Loss Design Range

Sizing in this region will lead to excessive head loss conditions.

Appendix D

Uponor PEX-a Hydronic Friction Loss Tables

5/16" Uponor PEX-a — 40% Propylene Glycol — Feet of Head per Foot of Tubing

Velocity (ft./sec.)	GPM	80°F 27°C	90°F 32°C	100°F 38°C	110°F 43°C	120°F 49°C	130°F 54°C	140°F 60°C	150°F 66°C	160°F 71°C	170°F 77°C	180°F 82°C	190°F 88°C	200°F 93°C
0.5	0.10	0.01528	0.01408	0.01311	0.01229	0.01158	0.01100	0.01048	0.01005	0.00968	0.00932	0.00906	0.00876	0.00855
0.6	0.13	0.02041	0.01885	0.01758	0.01651	0.01559	0.01482	0.01414	0.01357	0.01309	0.01262	0.01227	0.01188	0.01160
0.7	0.15	0.02611	0.02416	0.02257	0.02123	0.02006	0.01909	0.01824	0.01752	0.01691	0.01631	0.01587	0.01538	0.01502
0.8	0.17	0.03235	0.02999	0.02805	0.02641	0.02499	0.02380	0.02276	0.02188	0.02113	0.02040	0.01985	0.01925	0.01881
0.9	0.19	0.03913	0.03631	0.03400	0.03205	0.03036	0.02894	0.02768	0.02663	0.02574	0.02486	0.02420	0.02348	0.02295
1.0	0.21	0.04641	0.04312	0.04042	0.03813	0.03614	0.03448	0.03300	0.03177	0.03072	0.02968	0.02891	0.02806	0.02743
1.1	0.23	0.05419	0.05040	0.04728	0.04464	0.04235	0.04042	0.03871	0.03729	0.03607	0.03486	0.03397	0.03298	0.03225
1.2	0.25	0.06245	0.05813	0.05458	0.05157	0.04895	0.04674	0.04480	0.04317	0.04177	0.04039	0.03937	0.03823	0.03740
1.3	0.27	0.07118	0.06632	0.06231	0.05891	0.05595	0.05345	0.05125	0.04940	0.04782	0.04626	0.04510	0.04381	0.04287
1.4	0.29	0.08037	0.07494	0.07046	0.06665	0.06333	0.06054	0.05806	0.05599	0.05422	0.05246	0.05116	0.04971	0.04865
1.5	0.31	0.09002	0.08399	0.07901	0.07478	0.07109	0.06798	0.06523	0.06293	0.06095	0.05899	0.05754	0.05592	0.05475
1.6	0.33	0.10011	0.09346	0.08797	0.08330	0.07923	0.07579	0.07275	0.07020	0.06802	0.06585	0.06424	0.06245	0.06115
1.7	0.35	0.11064	0.10335	0.09733	0.09221	0.08773	0.08396	0.08061	0.07781	0.07541	0.07302	0.07126	0.06928	0.06785
1.8	0.38	0.12159	0.11365	0.10708	0.10148	0.09659	0.09247	0.08882	0.08575	0.08312	0.08051	0.07858	0.07642	0.07485
1.9	0.40	0.13297	0.12435	0.11721	0.11113	0.10582	0.10133	0.09735	0.09401	0.09115	0.08831	0.08620	0.08385	0.08214
2.0	0.42	0.14477	0.13545	0.12773	0.12115	0.11539	0.11053	0.10622	0.10260	0.09950	0.09641	0.09413	0.09158	0.08972
2.1	0.44	0.15699	0.14694	0.13862	0.13152	0.12531	0.12007	0.11541	0.11151	0.10816	0.10482	0.10236	0.09960	0.09759
2.2	0.46	0.16961	0.15882	0.14988	0.14225	0.13558	0.12994	0.12493	0.12073	0.11712	0.11353	0.11088	0.10790	0.10574
2.3	0.48	0.18263	0.17108	0.16151	0.15334	0.14618	0.14014	0.13477	0.13026	0.12639	0.12254	0.11969	0.11650	0.11417
2.4	0.50	0.19605	0.18372	0.17350	0.16477	0.15712	0.15066	0.14492	0.14010	0.13596	0.13184	0.12879	0.12537	0.12289
2.5	0.52	0.20987	0.19674	0.18585	0.17655	0.16840	0.16151	0.15539	0.15024	0.14583	0.14143	0.13817	0.13453	0.13187
2.6	0.54	0.22407	0.21013	0.19856	0.18868	0.18001	0.17268	0.16617	0.16069	0.15599	0.15131	0.14784	0.14396	0.14113
2.7	0.56	0.23867	0.22389	0.21162	0.20114	0.19194	0.18417	0.17725	0.17144	0.16645	0.16147	0.15779	0.15367	0.15067
2.8	0.58	0.25364	0.23801	0.22503	0.21394	0.20420	0.19597	0.18864	0.18248	0.17719	0.17192	0.16802	0.16365	0.16047

Recommended Head Loss Design Range

Sizing in this region will lead to excessive head loss conditions.

Appendix D

Uponor PEX-a Hydronic Friction Loss Tables

5/16" Uponor PEX-a — 50% Propylene Glycol — Feet of Head per Foot of Tubing

Velocity (ft./sec.)	GPM	80°F 27°C	90°F 32°C	100°F 38°C	110°F 43°C	120°F 49°C	130°F 54°C	140°F 60°C	150°F 66°C	160°F 71°C	170°F 77°C	180°F 82°C	190°F 88°C	200°F 93°C
0.5	0.10	0.01774	0.01620	0.01495	0.01391	0.01303	0.01228	0.01164	0.01109	0.01061	0.01018	0.00980	0.00948	0.00918
0.6	0.13	0.02360	0.02161	0.01997	0.01862	0.01748	0.01650	0.01566	0.01494	0.01431	0.01374	0.01324	0.01283	0.01243
0.7	0.15	0.03009	0.02761	0.02557	0.02387	0.02244	0.02121	0.02015	0.01924	0.01846	0.01774	0.01710	0.01658	0.01608
0.8	0.17	0.03718	0.03417	0.03170	0.02964	0.02789	0.02639	0.02510	0.02399	0.02303	0.02215	0.02136	0.02072	0.02011
0.9	0.19	0.04486	0.04129	0.03835	0.03589	0.03381	0.03203	0.03049	0.02916	0.02801	0.02695	0.02601	0.02525	0.02451
1.0	0.21	0.05309	0.04893	0.04550	0.04263	0.04019	0.03811	0.03630	0.03474	0.03339	0.03215	0.03104	0.03014	0.02927
1.1	0.23	0.06187	0.05709	0.05314	0.04983	0.04702	0.04461	0.04252	0.04072	0.03915	0.03772	0.03644	0.03540	0.03439
1.2	0.25	0.07119	0.06575	0.06125	0.05749	0.05428	0.05154	0.04915	0.04709	0.04530	0.04366	0.04219	0.04100	0.03985
1.3	0.27	0.08102	0.07490	0.06984	0.06559	0.06197	0.05887	0.05617	0.05384	0.05182	0.04996	0.04830	0.04695	0.04564
1.4	0.29	0.09135	0.08453	0.07887	0.07413	0.07008	0.06660	0.06358	0.06097	0.05870	0.05662	0.05476	0.05324	0.05177
1.5	0.31	0.10219	0.09463	0.08835	0.08309	0.07859	0.07473	0.07137	0.06847	0.06594	0.06363	0.06155	0.05986	0.05822
1.6	0.33	0.11351	0.10518	0.09827	0.09247	0.08751	0.08325	0.07954	0.07633	0.07354	0.07097	0.06868	0.06681	0.06500
1.7	0.35	0.12531	0.11620	0.10862	0.10226	0.09682	0.09215	0.08807	0.08455	0.08148	0.07866	0.07614	0.07408	0.07208
1.8	0.38	0.13758	0.12765	0.11940	0.11246	0.10652	0.10142	0.09697	0.09312	0.08976	0.08668	0.08392	0.08167	0.07948
1.9	0.40	0.15032	0.13955	0.13060	0.12306	0.11661	0.11106	0.10622	0.10203	0.09838	0.09503	0.09202	0.08957	0.08719
2.0	0.42	0.16351	0.15188	0.14220	0.13406	0.12707	0.12107	0.11583	0.11129	0.10734	0.10370	0.10044	0.09779	0.09520
2.1	0.44	0.17715	0.16464	0.15422	0.14544	0.13791	0.13144	0.12578	0.12089	0.11662	0.11269	0.10918	0.10631	0.10351
2.2	0.46	0.19124	0.17782	0.16663	0.15721	0.14912	0.14216	0.13608	0.13082	0.12623	0.12200	0.11822	0.11513	0.11212
2.3	0.48	0.20578	0.19142	0.17945	0.16936	0.16070	0.15324	0.14673	0.14108	0.13616	0.13163	0.12757	0.12425	0.12102
2.4	0.50	0.22074	0.20543	0.19266	0.18188	0.17264	0.16467	0.15771	0.15167	0.14641	0.14156	0.13722	0.13367	0.13022
2.5	0.52	0.23614	0.21985	0.20625	0.19478	0.18493	0.17644	0.16902	0.16259	0.15698	0.15180	0.14717	0.14338	0.13970
2.6	0.54	0.25196	0.23467	0.22023	0.20805	0.19758	0.18856	0.18067	0.17383	0.16785	0.16235	0.15742	0.15339	0.14947
2.7	0.56	0.26821	0.24989	0.23460	0.22168	0.21058	0.20101	0.19264	0.18538	0.17904	0.17320	0.16796	0.16369	0.15952

Recommended Head Loss Design Range

Sizing in this region will lead to excessive head loss conditions.

Appendix D

Uponor PEX-a Hydronic Friction Loss Tables

3/8" Uponor PEX-a — 100% Water — Feet of Head per Foot of Tubing

Velocity (ft./sec.)	GPM	80°F 27°C	90°F 32°C	100°F 38°C	110°F 43°C	120°F 49°C	130°F 54°C	140°F 60°C	150°F 66°C	160°F 71°C	170°F 77°C	180°F 82°C	190°F 88°C	200°F 93°C
0.6	0.18	0.00713	0.00685	0.00661	0.00640	0.00621	0.00604	0.00589	0.00575	0.00562	0.00550	0.00540	0.00530	0.00521
0.7	0.21	0.00966	0.00930	0.00899	0.00871	0.00845	0.00823	0.00802	0.00784	0.00767	0.00751	0.00737	0.00724	0.00711
0.8	0.24	0.01252	0.01206	0.01166	0.01130	0.01098	0.01069	0.01043	0.01019	0.00998	0.00977	0.00959	0.00943	0.00927
0.9	0.27	0.01567	0.01511	0.01461	0.01417	0.01378	0.01342	0.01310	0.01281	0.01254	0.01229	0.01207	0.01186	0.01167
1.0	0.30	0.01912	0.01845	0.01785	0.01732	0.01685	0.01642	0.01603	0.01568	0.01535	0.01505	0.01478	0.01453	0.01430
1.1	0.33	0.02286	0.02207	0.02136	0.02074	0.02017	0.01967	0.01921	0.01879	0.01841	0.01805	0.01773	0.01744	0.01716
1.2	0.36	0.02688	0.02595	0.02513	0.02441	0.02375	0.02316	0.02263	0.02214	0.02170	0.02128	0.02091	0.02056	0.02024
1.3	0.39	0.03117	0.03011	0.02917	0.02833	0.02758	0.02690	0.02629	0.02573	0.02522	0.02474	0.02431	0.02392	0.02355
1.4	0.42	0.03572	0.03452	0.03345	0.03251	0.03165	0.03088	0.03019	0.02955	0.02897	0.02843	0.02794	0.02749	0.02706
1.5	0.45	0.04054	0.03919	0.03799	0.03692	0.03596	0.03510	0.03431	0.03359	0.03294	0.03233	0.03178	0.03127	0.03079
1.6	0.48	0.04562	0.04411	0.04277	0.04158	0.04051	0.03954	0.03867	0.03786	0.03713	0.03645	0.03583	0.03526	0.03473
1.7	0.51	0.05095	0.04928	0.04780	0.04648	0.04529	0.04421	0.04324	0.04235	0.04154	0.04078	0.04010	0.03947	0.03888
1.8	0.54	0.05653	0.05469	0.05306	0.05161	0.05029	0.04911	0.04804	0.04706	0.04616	0.04533	0.04457	0.04387	0.04322
1.9	0.57	0.06237	0.06035	0.05856	0.05697	0.05553	0.05423	0.05306	0.05198	0.05100	0.05008	0.04925	0.04848	0.04777
2.0	0.60	0.06844	0.06624	0.06429	0.06255	0.06098	0.05957	0.05829	0.05711	0.05604	0.05504	0.05413	0.05330	0.05252
2.1	0.63	0.07476	0.07237	0.07025	0.06836	0.06666	0.06512	0.06373	0.06245	0.06129	0.06020	0.05922	0.05831	0.05746
2.2	0.66	0.08131	0.07873	0.07644	0.07440	0.07255	0.07089	0.06939	0.06800	0.06674	0.06556	0.06450	0.06351	0.06259
2.3	0.69	0.08810	0.08532	0.08285	0.08065	0.07866	0.07687	0.07525	0.07376	0.07240	0.07112	0.06998	0.06892	0.06792
2.4	0.72	0.09513	0.09214	0.08949	0.08713	0.08499	0.08306	0.08132	0.07971	0.07826	0.07689	0.07565	0.07451	0.07344
2.5	0.75	0.10239	0.09919	0.09635	0.09382	0.09153	0.08946	0.08760	0.08588	0.08431	0.08284	0.08152	0.08030	0.07915
2.6	0.78	0.10987	0.10646	0.10342	0.10072	0.09827	0.09607	0.09408	0.09224	0.09057	0.08899	0.08758	0.08627	0.08505
2.7	0.81	0.11759	0.11395	0.11072	0.10784	0.10523	0.10288	0.10076	0.09879	0.09701	0.09534	0.09384	0.09244	0.09113
2.8	0.84	0.12553	0.12167	0.11823	0.11517	0.11240	0.10990	0.10764	0.10555	0.10366	0.10188	0.10028	0.09879	0.09740
2.9	0.87	0.13369	0.12960	0.12595	0.12270	0.11976	0.11712	0.11472	0.11250	0.11049	0.10860	0.10690	0.10533	0.10385
3.0	0.90	0.14208	0.13775	0.13388	0.13045	0.12734	0.12453	0.12199	0.11965	0.11752	0.11552	0.11372	0.11205	0.11049
3.1	0.93	0.15069	0.14611	0.14203	0.13840	0.13511	0.13215	0.12946	0.12699	0.12474	0.12262	0.12072	0.11895	0.11730
3.2	0.96	0.15951	0.15469	0.15038	0.14656	0.14309	0.13996	0.13713	0.13452	0.13214	0.12991	0.12790	0.12604	0.12430
3.3	0.99	0.16856	0.16348	0.15895	0.15492	0.15127	0.14797	0.14499	0.14224	0.13974	0.13739	0.13527	0.13331	0.13147
3.4	1.02	0.17782	0.17248	0.16772	0.16348	0.15964	0.15618	0.15304	0.15015	0.14752	0.14504	0.14282	0.14075	0.13883
3.5	1.05	0.18729	0.18169	0.17669	0.17225	0.16821	0.16458	0.16129	0.15825	0.15549	0.15289	0.15055	0.14838	0.14636
3.6	1.08	0.19698	0.19111	0.18587	0.18121	0.17698	0.17317	0.16972	0.16653	0.16364	0.16091	0.15846	0.15619	0.15406
3.7	1.11	0.20688	0.20074	0.19525	0.19037	0.18595	0.18196	0.17834	0.17500	0.17197	0.16912	0.16655	0.16417	0.16194
3.8	1.14	0.21700	0.21057	0.20484	0.19974	0.19511	0.19093	0.18715	0.18366	0.18049	0.17750	0.17482	0.17233	0.17000
3.8	1.14	0.22732	0.22061	0.21462	0.20929	0.20446	0.20010	0.19615	0.19250	0.18919	0.18607	0.18327	0.18066	0.17823

Recommended Head Loss Design Range

Sizing in this region will lead to excessive head loss conditions.

Appendix D

Uponor PEX-a Hydronic Friction Loss Tables

3/8" Uponor PEX-a — 30% Propylene Glycol — Feet of Head per Foot of Tubing

Velocity (ft./sec.)	GPM	80°F 27°C	90°F 32°C	100°F 38°C	110°F 43°C	120°F 49°C	130°F 54°C	140°F 60°C	150°F 66°C	160°F 71°C	170°F 77°C	180°F 82°C	190°F 88°C	200°F 93°C
0.5	0.15	0.01025	0.00960	0.00904	0.00857	0.00817	0.00782	0.00751	0.00726	0.00702	0.00680	0.00662	0.00644	0.00631
0.6	0.18	0.01377	0.01292	0.01219	0.01157	0.01105	0.01059	0.01017	0.00984	0.00952	0.00923	0.00899	0.00876	0.00859
0.7	0.21	0.01771	0.01663	0.01572	0.01493	0.01427	0.01369	0.01316	0.01275	0.01234	0.01197	0.01167	0.01137	0.01115
0.8	0.24	0.02203	0.02072	0.01960	0.01864	0.01783	0.01712	0.01647	0.01596	0.01546	0.01501	0.01464	0.01427	0.01400
0.9	0.27	0.02674	0.02517	0.02384	0.02269	0.02172	0.02086	0.02009	0.01947	0.01888	0.01833	0.01788	0.01744	0.01711
1.0	0.30	0.03182	0.02998	0.02841	0.02706	0.02592	0.02491	0.02400	0.02328	0.02257	0.02193	0.02140	0.02088	0.02049
1.1	0.33	0.03725	0.03513	0.03332	0.03175	0.03043	0.02926	0.02820	0.02737	0.02655	0.02580	0.02519	0.02458	0.02413
1.2	0.36	0.04304	0.04061	0.03854	0.03675	0.03524	0.03390	0.03269	0.03173	0.03080	0.02994	0.02923	0.02854	0.02802
1.3	0.39	0.04917	0.04642	0.04408	0.04206	0.04035	0.03883	0.03746	0.03637	0.03531	0.03434	0.03354	0.03275	0.03216
1.4	0.42	0.05563	0.05256	0.04994	0.04766	0.04575	0.04404	0.04250	0.04128	0.04009	0.03900	0.03809	0.03720	0.03655
1.5	0.45	0.06242	0.05901	0.05609	0.05356	0.05143	0.04953	0.04782	0.04645	0.04512	0.04390	0.04290	0.04190	0.04117
1.6	0.48	0.06954	0.06577	0.06255	0.05975	0.05739	0.05529	0.05339	0.05188	0.05041	0.04906	0.04794	0.04685	0.04604
1.7	0.51	0.07698	0.07284	0.06930	0.06622	0.06363	0.06132	0.05923	0.05757	0.05595	0.05446	0.05323	0.05202	0.05113
1.8	0.54	0.08473	0.08020	0.07634	0.07298	0.07014	0.06761	0.06533	0.06351	0.06173	0.06011	0.05876	0.05744	0.05646
1.9	0.57	0.09279	0.08787	0.08367	0.08001	0.07692	0.07417	0.07168	0.06970	0.06776	0.06599	0.06452	0.06308	0.06201
2.0	0.60	0.10116	0.09583	0.09128	0.08731	0.08397	0.08098	0.07829	0.07613	0.07404	0.07211	0.07052	0.06895	0.06779
2.1	0.63	0.10983	0.10408	0.09917	0.09489	0.09128	0.08805	0.08514	0.08281	0.08055	0.07847	0.07675	0.07505	0.07380
2.2	0.66	0.11880	0.11262	0.10734	0.10273	0.09885	0.09538	0.09224	0.08974	0.08730	0.08506	0.08320	0.08137	0.08003
2.3	0.69	0.12807	0.12145	0.11578	0.11084	0.10667	0.10295	0.09958	0.09690	0.09428	0.09188	0.08988	0.08792	0.08647
2.4	0.72	0.13763	0.13055	0.12449	0.11921	0.11475	0.11078	0.10717	0.10430	0.10149	0.09892	0.09679	0.09468	0.09313
2.5	0.75	0.14748	0.13993	0.13347	0.12785	0.12309	0.11884	0.11500	0.11193	0.10894	0.10619	0.10391	0.10167	0.10001
2.6	0.78	0.15761	0.14959	0.14272	0.13674	0.13167	0.12716	0.12306	0.11980	0.11661	0.11369	0.11126	0.10887	0.10711
2.7	0.81	0.16803	0.15953	0.15224	0.14588	0.14051	0.13571	0.13136	0.12790	0.12451	0.12140	0.11883	0.11629	0.11441
2.8	0.84	0.17873	0.16973	0.16201	0.15528	0.14959	0.14451	0.13990	0.13622	0.13263	0.12934	0.12661	0.12392	0.12193
2.9	0.87	0.18972	0.18020	0.17205	0.16493	0.15891	0.15354	0.14867	0.14478	0.14098	0.13750	0.13461	0.13176	0.12966
3.0	0.90	0.20098	0.19094	0.18234	0.17483	0.16848	0.16281	0.15767	0.15356	0.14955	0.14588	0.14282	0.13981	0.13759
3.1	0.93	0.21251	0.20195	0.19289	0.18498	0.17829	0.17231	0.16689	0.16257	0.15834	0.15447	0.15125	0.14807	0.14573
3.2	0.96	0.22432	0.21322	0.20369	0.19537	0.18834	0.18205	0.17635	0.17180	0.16735	0.16327	0.15988	0.15655	0.15408
3.3	0.99	0.23640	0.22475	0.21475	0.20601	0.19863	0.19202	0.18603	0.18125	0.17658	0.17229	0.16873	0.16522	0.16264

Recommended Head Loss Design Range

Sizing in this region will lead to excessive head loss conditions.

Appendix D

Uponor PEX-a Hydronic Friction Loss Tables

3/8" Uponor PEX-a — 40% Propylene Glycol — Feet of Head per Foot of Tubing

Velocity (ft./sec.)	GPM	80°F 27°C	90°F 32°C	100°F 38°C	110°F 43°C	120°F 49°C	130°F 54°C	140°F 60°C	150°F 66°C	160°F 71°C	170°F 77°C	180°F 82°C	190°F 88°C	200°F 93°C
0.5	0.15	0.01183	0.01093	0.01019	0.00957	0.00903	0.00859	0.00819	0.00787	0.00759	0.00731	0.00711	0.00688	0.00672
0.6	0.18	0.01583	0.01465	0.01369	0.01288	0.01218	0.01159	0.01107	0.01064	0.01027	0.00991	0.00964	0.00934	0.00913
0.7	0.21	0.02028	0.01881	0.01760	0.01658	0.01570	0.01496	0.01430	0.01375	0.01329	0.01283	0.01249	0.01211	0.01183
0.8	0.24	0.02517	0.02338	0.02191	0.02066	0.01958	0.01867	0.01786	0.01719	0.01662	0.01605	0.01564	0.01517	0.01483
0.9	0.27	0.03048	0.02834	0.02659	0.02510	0.02380	0.02271	0.02175	0.02095	0.02026	0.01958	0.01908	0.01852	0.01811
1.0	0.30	0.03619	0.03369	0.03163	0.02989	0.02837	0.02709	0.02596	0.02501	0.02420	0.02340	0.02281	0.02215	0.02167
1.1	0.33	0.04229	0.03941	0.03703	0.03502	0.03326	0.03178	0.03047	0.02937	0.02844	0.02750	0.02682	0.02605	0.02549
1.2	0.36	0.04878	0.04549	0.04278	0.04048	0.03847	0.03678	0.03528	0.03403	0.03295	0.03189	0.03110	0.03022	0.02958
1.3	0.39	0.05565	0.05194	0.04887	0.04627	0.04400	0.04208	0.04039	0.03897	0.03775	0.03654	0.03565	0.03465	0.03392
1.4	0.42	0.06287	0.05873	0.05530	0.05238	0.04983	0.04769	0.04578	0.04419	0.04282	0.04146	0.04046	0.03933	0.03852
1.5	0.45	0.07046	0.06586	0.06205	0.05881	0.05597	0.05358	0.05146	0.04968	0.04816	0.04664	0.04552	0.04427	0.04336
1.6	0.48	0.07841	0.07333	0.06912	0.06554	0.06241	0.05976	0.05742	0.05545	0.05376	0.05209	0.05085	0.04946	0.04845
1.7	0.51	0.08670	0.08113	0.07651	0.07258	0.06913	0.06623	0.06365	0.06149	0.05963	0.05778	0.05642	0.05489	0.05378
1.8	0.54	0.09533	0.08925	0.08421	0.07992	0.07615	0.07298	0.07015	0.06779	0.06575	0.06373	0.06224	0.06056	0.05934
1.9	0.57	0.10430	0.09770	0.09222	0.08755	0.08346	0.08000	0.07693	0.07435	0.07213	0.06993	0.06830	0.06648	0.06515
2.0	0.60	0.11361	0.10646	0.10053	0.09547	0.09104	0.08729	0.08396	0.08117	0.07876	0.07637	0.07461	0.07262	0.07118
2.1	0.63	0.12324	0.11554	0.10915	0.10369	0.09890	0.09486	0.09126	0.08824	0.08564	0.08306	0.08115	0.07901	0.07745
2.2	0.66	0.13320	0.12492	0.11806	0.11219	0.10704	0.10269	0.09882	0.09556	0.09277	0.08999	0.08793	0.08562	0.08394
2.3	0.69	0.14348	0.13462	0.12726	0.12097	0.11545	0.11078	0.10663	0.10314	0.10014	0.09715	0.09494	0.09246	0.09066
2.4	0.72	0.15408	0.14461	0.13675	0.13003	0.12413	0.11913	0.11469	0.11096	0.10775	0.10455	0.10218	0.09953	0.09760
2.5	0.75	0.16499	0.15491	0.14653	0.13936	0.13307	0.12775	0.12301	0.11902	0.11560	0.11218	0.10966	0.10682	0.10476
2.6	0.78	0.17621	0.16550	0.15659	0.14897	0.14228	0.13661	0.13157	0.12733	0.12368	0.12005	0.11736	0.11434	0.11214
2.7	0.81	0.18774	0.17639	0.16694	0.15886	0.15175	0.14574	0.14038	0.13588	0.13200	0.12814	0.12528	0.12208	0.11974
2.8	0.84	0.19958	0.18756	0.17757	0.16901	0.16148	0.15511	0.14944	0.14466	0.14056	0.13647	0.13343	0.13003	0.12755
2.9	0.87	0.21172	0.19903	0.18847	0.17942	0.17147	0.16473	0.15874	0.15369	0.14934	0.14501	0.14180	0.13821	0.13558
3.0	0.90	0.22416	0.21078	0.19964	0.19010	0.18171	0.17461	0.16827	0.16294	0.15836	0.15379	0.15040	0.14660	0.14383
3.1	0.93	0.23690	0.22282	0.21109	0.20105	0.19221	0.18472	0.17805	0.17243	0.16760	0.16278	0.15921	0.15520	0.15228
3.2	0.96	0.24993	0.23514	0.22282	0.21225	0.20296	0.19508	0.18807	0.18215	0.17707	0.17200	0.16824	0.16402	0.16094

Recommended Head Loss Design Range

Sizing in this region will lead to excessive head loss conditions.

Appendix D

Uponor PEX-a Hydronic Friction Loss Tables

3/8" Uponor PEX-a — 50% Propylene Glycol — Feet of Head per Foot of Tubing

Velocity (ft./sec.)	GPM	80°F 27°C	90°F 32°C	100°F 38°C	110°F 43°C	120°F 49°C	130°F 54°C	140°F 60°C	150°F 66°C	160°F 71°C	170°F 77°C	180°F 82°C	190°F 88°C	200°F 93°C
0.5	0.15	0.01368	0.01252	0.01158	0.01079	0.01013	0.00956	0.00908	0.00866	0.00830	0.00796	0.00767	0.00743	0.00720
0.6	0.18	0.01823	0.01674	0.01550	0.01448	0.01361	0.01287	0.01223	0.01168	0.01121	0.01077	0.01038	0.01007	0.00977
0.7	0.21	0.02329	0.02142	0.01988	0.01859	0.01750	0.01657	0.01576	0.01507	0.01447	0.01392	0.01343	0.01303	0.01265
0.8	0.24	0.02882	0.02655	0.02468	0.02311	0.02178	0.02064	0.01966	0.01881	0.01807	0.01740	0.01680	0.01631	0.01583
0.9	0.27	0.03482	0.03212	0.02989	0.02802	0.02644	0.02508	0.02390	0.02288	0.02200	0.02119	0.02047	0.01989	0.01932
1.0	0.30	0.04126	0.03811	0.03550	0.03332	0.03146	0.02987	0.02848	0.02729	0.02625	0.02530	0.02445	0.02376	0.02309
1.1	0.33	0.04813	0.04450	0.04150	0.03898	0.03683	0.03499	0.03339	0.03201	0.03081	0.02971	0.02872	0.02792	0.02714
1.2	0.36	0.05542	0.05130	0.04788	0.04501	0.04256	0.04045	0.03862	0.03704	0.03567	0.03441	0.03328	0.03236	0.03147
1.3	0.39	0.06313	0.05848	0.05462	0.05138	0.04862	0.04624	0.04417	0.04238	0.04083	0.03940	0.03812	0.03708	0.03606
1.4	0.42	0.07123	0.06604	0.06173	0.05811	0.05501	0.05235	0.05003	0.04802	0.04628	0.04467	0.04323	0.04206	0.04093
1.5	0.45	0.07973	0.07398	0.06919	0.06517	0.06173	0.05877	0.05619	0.05395	0.05201	0.05022	0.04862	0.04732	0.04605
1.6	0.48	0.08862	0.08228	0.07701	0.07257	0.06877	0.06550	0.06264	0.06018	0.05803	0.05605	0.05428	0.05283	0.05143
1.7	0.51	0.09789	0.09095	0.08516	0.08029	0.07612	0.07253	0.06940	0.06668	0.06432	0.06214	0.06019	0.05861	0.05706
1.8	0.54	0.10753	0.09996	0.09366	0.08834	0.08379	0.07986	0.07644	0.07347	0.07089	0.06851	0.06637	0.06463	0.06294
1.9	0.57	0.11755	0.10933	0.10248	0.09671	0.09176	0.08749	0.08377	0.08054	0.07772	0.07513	0.07281	0.07091	0.06907
2.0	0.60	0.12792	0.11905	0.11164	0.10539	0.10003	0.09541	0.09138	0.08788	0.08483	0.08201	0.07949	0.07744	0.07543
2.1	0.63	0.13866	0.12910	0.12112	0.11439	0.10861	0.10362	0.09926	0.09549	0.09219	0.08916	0.08643	0.08421	0.08204
2.2	0.66	0.14975	0.13949	0.13092	0.12369	0.11747	0.11212	0.10743	0.10337	0.09982	0.09655	0.09362	0.09122	0.08889
2.3	0.69	0.16119	0.15021	0.14104	0.13329	0.12664	0.12089	0.11587	0.11151	0.10770	0.10420	0.10105	0.09848	0.09598
2.4	0.72	0.17298	0.16127	0.15147	0.14320	0.13609	0.12995	0.12457	0.11991	0.11584	0.11209	0.10872	0.10597	0.10329
2.5	0.75	0.18511	0.17264	0.16222	0.15340	0.14582	0.13928	0.13355	0.12858	0.12424	0.12023	0.11664	0.11370	0.11084
2.6	0.78	0.19758	0.18434	0.17326	0.16390	0.15584	0.14888	0.14279	0.13750	0.13288	0.12862	0.12479	0.12167	0.11862
2.7	0.81	0.21039	0.19636	0.18462	0.17469	0.16614	0.15876	0.15229	0.14668	0.14177	0.13725	0.13318	0.12986	0.12663
2.8	0.84	0.22352	0.20869	0.19627	0.18577	0.17672	0.16890	0.16205	0.15611	0.15091	0.14611	0.14181	0.13829	0.13486
2.9	0.87	0.23699	0.22134	0.20823	0.19713	0.18757	0.17931	0.17207	0.16579	0.16029	0.15522	0.15066	0.14694	0.14331
3.0	0.90	0.25079	0.23430	0.22048	0.20878	0.19870	0.18999	0.18235	0.17572	0.16992	0.16456	0.15975	0.15582	0.15199

Recommended Head Loss Design Range

Sizing in this region will lead to excessive head loss conditions.

Appendix D

Uponor PEX-a Hydronic Friction Loss Tables

1/2" Uponor PEX-a — 100% Water — Feet of Head per Foot of Tubing

Velocity (ft./sec.)	GPM	40°F 4°C	45°F 7°C	50°F 10°C	55°F 13°C	60°F 16°C	65°F 18°C	70°F 21°C	80°F 27°C	90°F 32°C	100°F 38°C	110°F 43°C	120°F 49°C	130°F 54°C	140°F 60°C	150°F 66°C	160°F 71°C	170°F 77°C	180°F 82°C	190°F 88°C	200°F 93°C
3.8	2.10	0.19167	0.18257	0.17230	0.16905	0.16565	0.16285	0.15992	0.15490	0.15048	0.14652	0.14300	0.13980	0.13692	0.13430	0.13188	0.12968	0.12760	0.12574	0.12400	0.12238
3.9	2.15	0.20046	0.19097	0.18026	0.17688	0.17333	0.17040	0.16735	0.16211	0.15750	0.15337	0.14970	0.14636	0.14335	0.14061	0.13808	0.13579	0.13362	0.13168	0.12987	0.12818
4.0	2.21	0.20942	0.19954	0.18838	0.18485	0.18115	0.17811	0.17493	0.16947	0.16466	0.16036	0.15653	0.15305	0.14990	0.14705	0.14442	0.14203	0.13977	0.13774	0.13585	0.13409
4.1	2.26	0.21855	0.20827	0.19665	0.19298	0.18913	0.18596	0.18265	0.17697	0.17196	0.16748	0.16349	0.15987	0.15659	0.15362	0.15088	0.14839	0.14604	0.14392	0.14195	0.14012
4.2	2.32	0.22785	0.21716	0.20508	0.20127	0.19726	0.19397	0.19052	0.18461	0.17940	0.17474	0.17059	0.16682	0.16341	0.16032	0.15747	0.15487	0.15243	0.15022	0.14818	0.14627
4.3	2.38	0.23732	0.22621	0.21367	0.20970	0.20554	0.20212	0.19854	0.19239	0.18698	0.18213	0.17782	0.17390	0.17036	0.16715	0.16418	0.16148	0.15894	0.15665	0.15452	0.15253
4.4	2.43	0.24695	0.23542	0.22240	0.21829	0.21397	0.21041	0.20669	0.20031	0.19469	0.18966	0.18518	0.18111	0.17743	0.17410	0.17101	0.16821	0.16557	0.16319	0.16098	0.15891
4.5	2.49	0.25674	0.24480	0.23129	0.22702	0.22254	0.21885	0.21500	0.20838	0.20254	0.19733	0.19268	0.18845	0.18464	0.18117	0.17797	0.17506	0.17232	0.16985	0.16756	0.16542
4.6	2.54	0.26670	0.25433	0.24033	0.23591	0.23126	0.22744	0.22344	0.21658	0.21053	0.20512	0.20030	0.19592	0.19197	0.18838	0.18506	0.18204	0.17919	0.17664	0.17426	0.17203

Recommended Head Loss Design Range

Sizing in this region will lead to excessive head loss conditions.

Appendix D

Uponor PEX-a Hydronic Friction Loss Tables

1/2" Uponor PEX-a — 30% Propylene Glycol — Feet of Head per Foot of Tubing

Velocity (ft./sec.)	GPM	40°F 4°C	45°F 7°C	50°F 10°C	55°F 13°C	60°F 16°C	65°F 18°C	70°F 21°C	80°F 27°C	90°F 32°C	100°F 38°C	110°F 43°C	120°F 49°C	130°F 54°C	140°F 60°C	150°F 66°C	160°F 71°C	170°F 77°C	180°F 82°C	190°F 88°C	200°F 93°C
3.8	2.10	0.26052	0.25159	0.24202	0.23459	0.22666	0.22026	0.21344	0.20237	0.19285	0.18464	0.17745	0.17134	0.16586	0.16088	0.15689	0.15298	0.14939	0.14640	0.14344	0.14125
3.9	2.15	0.27219	0.26289	0.25293	0.24519	0.23693	0.23026	0.22315	0.21162	0.20169	0.19313	0.18563	0.17926	0.17355	0.16835	0.16419	0.16011	0.15636	0.15324	0.15015	0.14787
4.0	2.21	0.28408	0.27441	0.26404	0.25598	0.24739	0.24044	0.23305	0.22104	0.21070	0.20179	0.19398	0.18734	0.18139	0.17597	0.17163	0.16739	0.16347	0.16022	0.15700	0.15462
4.1	2.26	0.29618	0.28613	0.27535	0.26698	0.25804	0.25082	0.24313	0.23064	0.21988	0.21061	0.20248	0.19557	0.18938	0.18374	0.17922	0.17480	0.17073	0.16734	0.16398	0.16151

Recommended Head Loss Design Range

Sizing in this region will lead to excessive head loss conditions.

Appendix D

Uponor PEX-a Hydronic Friction Loss Tables

5/8" Uponor PEX-a — 100% Water — Feet of Head per Foot of Tubing

Velocity (ft./sec.)	GPM	40°F 4°C	45°F 7°C	50°F 10°C	55°F 13°C	60°F 16°C	65°F 18°C	70°F 21°C	80°F 27°C	90°F 32°C	100°F 38°C	110°F 43°C	120°F 49°C	130°F 54°C	140°F 60°C	150°F 66°C	160°F 71°C	170°F 77°C	180°F 82°C	190°F 88°C	200°F 93°C
3.9	3.15	0.15756	0.15026	0.14201	0.13940	0.13666	0.13440	0.13204	0.12799	0.12442	0.12122	0.11837	0.11579	0.11345	0.11132	0.10936	0.10758	0.10589	0.10438	0.10297	0.10165
4.0	3.23	0.16463	0.15703	0.14842	0.14570	0.14285	0.14050	0.13804	0.13381	0.13009	0.12676	0.12379	0.12109	0.11865	0.11644	0.11439	0.11253	0.11078	0.10920	0.10773	0.10635
4.1	3.31	0.17183	0.16392	0.15496	0.15213	0.14916	0.14671	0.14415	0.13975	0.13587	0.13241	0.12931	0.12650	0.12396	0.12165	0.11952	0.11758	0.11575	0.11411	0.11258	0.11115
4.2	3.39	0.17917	0.17094	0.16163	0.15868	0.15559	0.15304	0.15038	0.14580	0.14177	0.13816	0.13494	0.13202	0.12937	0.12697	0.12475	0.12273	0.12083	0.11912	0.11752	0.11604
4.3	3.47	0.18664	0.17809	0.16841	0.16535	0.16214	0.15949	0.15672	0.15197	0.14777	0.14402	0.14068	0.13763	0.13489	0.13239	0.13008	0.12798	0.12600	0.12422	0.12257	0.12102
4.4	3.55	0.19424	0.18536	0.17532	0.17214	0.16880	0.16606	0.16318	0.15824	0.15389	0.14999	0.14652	0.14336	0.14050	0.13791	0.13551	0.13333	0.13127	0.12942	0.12770	0.12609
4.5	3.63	0.20197	0.19277	0.18235	0.17905	0.17559	0.17274	0.16976	0.16463	0.16011	0.15607	0.15246	0.14918	0.14622	0.14353	0.14104	0.13878	0.13664	0.13472	0.13293	0.13126
4.6	3.71	0.20983	0.20030	0.18950	0.18608	0.18249	0.17954	0.17644	0.17113	0.16645	0.16225	0.15851	0.15511	0.15204	0.14925	0.14667	0.14432	0.14210	0.14011	0.13826	0.13652
4.7	3.79	0.21782	0.20795	0.19677	0.19323	0.18951	0.18645	0.18325	0.17774	0.17289	0.16854	0.16467	0.16114	0.15796	0.15506	0.15239	0.14996	0.14766	0.14560	0.14368	0.14188
4.8	3.87	0.22595	0.21573	0.20416	0.20049	0.19664	0.19348	0.19016	0.18446	0.17944	0.17494	0.17092	0.16728	0.16398	0.16098	0.15821	0.15569	0.15332	0.15118	0.14919	0.14733
4.9	3.95	0.23420	0.22363	0.21166	0.20787	0.20389	0.20062	0.19719	0.19129	0.18609	0.18144	0.17729	0.17351	0.17010	0.16700	0.16413	0.16152	0.15907	0.15685	0.15479	0.15287
5.0	4.03	0.24258	0.23166	0.21929	0.21537	0.21126	0.20787	0.20433	0.19823	0.19286	0.18805	0.18375	0.17985	0.17632	0.17311	0.17015	0.16745	0.16491	0.16262	0.16049	0.15850
5.1	4.11	0.25109	0.23981	0.22704	0.22299	0.21874	0.21524	0.21158	0.20528	0.19973	0.19476	0.19032	0.18628	0.18264	0.17932	0.17626	0.17347	0.17085	0.16848	0.16628	0.16422
5.2	4.19	0.25973	0.24809	0.23490	0.23072	0.22634	0.22272	0.21894	0.21244	0.20671	0.20157	0.19699	0.19282	0.18906	0.18563	0.18247	0.17959	0.17688	0.17443	0.17216	0.17003

Recommended Head Loss Design Range

Sizing in this region will lead to excessive head loss conditions.

Appendix D

Uponor PEX-a Hydronic Friction Loss Tables

5/8" Uponor PEX-a — 30% Propylene Glycol — Feet of Head per Foot of Tubing

Velocity (ft./sec.)	GPM	40°F 4°C	45°F 7°C	50°F 10°C	55°F 13°C	60°F 16°C	65°F 18°C	70°F 21°C	80°F 27°C	90°F 32°C	100°F 38°C	110°F 43°C	120°F 49°C	130°F 54°C	140°F 60°C	150°F 66°C	160°F 71°C	170°F 77°C	180°F 82°C	190°F 88°C	200°F 93°C
3.9	3.15	0.21244	0.20536	0.19775	0.19184	0.18553	0.18042	0.17498	0.16613	0.15851	0.15192	0.14615	0.14124	0.13683	0.13281	0.12960	0.12644	0.12354	0.12112	0.11873	0.11696
4.0	3.23	0.22176	0.21439	0.20648	0.20032	0.19375	0.18843	0.18277	0.17356	0.16561	0.15876	0.15274	0.14762	0.14303	0.13884	0.13549	0.13220	0.12917	0.12665	0.12416	0.12231
4.1	3.31	0.23125	0.22359	0.21536	0.20896	0.20213	0.19660	0.19071	0.18112	0.17286	0.16572	0.15946	0.15413	0.14935	0.14499	0.14150	0.13807	0.13492	0.13229	0.12970	0.12777
4.2	3.39	0.24091	0.23295	0.22441	0.21776	0.21066	0.20491	0.19879	0.18882	0.18023	0.17281	0.16630	0.16076	0.15578	0.15125	0.14762	0.14406	0.14078	0.13804	0.13534	0.13334
4.3	3.47	0.25074	0.24248	0.23361	0.22671	0.21933	0.21337	0.20701	0.19667	0.18774	0.18003	0.17327	0.16751	0.16234	0.15763	0.15385	0.15015	0.14674	0.14390	0.14109	0.13901
4.4	3.55	0.26073	0.25216	0.24297	0.23581	0.22816	0.22198	0.21538	0.20465	0.19538	0.18738	0.18036	0.17438	0.16902	0.16412	0.16020	0.15636	0.15282	0.14987	0.14695	0.14479
4.5	3.63	0.27089	0.26201	0.25248	0.24507	0.23714	0.23073	0.22389	0.21276	0.20316	0.19486	0.18758	0.18138	0.17581	0.17073	0.16667	0.16268	0.15900	0.15594	0.15291	0.15067
4.6	3.71	0.28121	0.27202	0.26216	0.25448	0.24627	0.23963	0.23254	0.22101	0.21106	0.20247	0.19492	0.18849	0.18272	0.17746	0.17324	0.16910	0.16529	0.16212	0.15898	0.15665
4.7	3.79	0.29169	0.28219	0.27198	0.26404	0.25554	0.24867	0.24134	0.22940	0.21910	0.21020	0.20238	0.19572	0.18975	0.18430	0.17993	0.17564	0.17169	0.16840	0.16515	0.16274

Recommended Head Loss Design Range

Sizing in this region will lead to excessive head loss conditions.

Appendix D

Uponor PEX-a Hydronic Friction Loss Tables

5/8" Uponor PEX-a — 40% Propylene Glycol — Feet of Head per Foot of Tubing

Velocity (ft./sec.)	GPM	40°F 4°C	45°F 7°C	50°F 10°C	55°F 13°C	60°F 16°C	65°F 18°C	70°F 21°C	80°F 27°C	90°F 32°C	100°F 38°C	110°F 43°C	120°F 49°C	130°F 54°C	140°F 60°C	150°F 66°C	160°F 71°C	170°F 77°C	180°F 82°C	190°F 88°C	200°F 93°C
3.9	3.15	0.24898	0.23862	0.22739	0.21905	0.21006	0.20318	0.19580	0.18392	0.17392	0.16553	0.15831	0.15192	0.14648	0.14161	0.13750	0.13395	0.13040	0.12776	0.12480	0.12263
4.0	3.23	0.25977	0.24899	0.23732	0.22864	0.21938	0.21212	0.20444	0.19208	0.18167	0.17293	0.16541	0.15875	0.15308	0.14801	0.14373	0.14003	0.13633	0.13358	0.13049	0.12823
4.1	3.31	0.27074	0.25955	0.24742	0.23840	0.22867	0.22123	0.21324	0.20039	0.18956	0.18047	0.17264	0.16571	0.15982	0.15454	0.15008	0.14622	0.14237	0.13951	0.13629	0.13393
4.2	3.39	0.28191	0.27029	0.25770	0.24833	0.23823	0.23050	0.22221	0.20885	0.19759	0.18815	0.18001	0.17281	0.16667	0.16118	0.15654	0.15254	0.14853	0.14555	0.14220	0.13975
4.3	3.47	0.29327	0.28121	0.26815	0.25843	0.24796	0.23993	0.23132	0.21746	0.20577	0.19596	0.18751	0.18003	0.17365	0.16795	0.16313	0.15897	0.15480	0.15170	0.14822	0.14568
4.4	3.55	0.30481	0.29232	0.27878	0.26871	0.25785	0.24953	0.24060	0.22622	0.21409	0.20392	0.19514	0.18738	0.18076	0.17484	0.16983	0.16551	0.16119	0.15797	0.15435	0.15171
4.5	3.63	0.31654	0.30361	0.28959	0.27915	0.26790	0.25928	0.25003	0.23513	0.22256	0.21201	0.20291	0.19485	0.18799	0.18185	0.17666	0.17217	0.16768	0.16435	0.16059	0.15785
4.6	3.71	0.32845	0.31507	0.30056	0.28976	0.27812	0.26919	0.25961	0.24418	0.23116	0.22023	0.21080	0.20246	0.19535	0.18898	0.18360	0.17895	0.17430	0.17084	0.16694	0.16410
4.7	3.79	0.29169	0.28219	0.27198	0.26404	0.25554	0.24867	0.24134	0.22940	0.21910	0.21020	0.20238	0.19572	0.18975	0.18430	0.17993	0.17564	0.17169	0.16840	0.16515	0.16274

Sizing in this region will lead to excessive head loss conditions.

Recommended Head Loss Design Range

Appendix D

Uponor PEX-a Hydronic Friction Loss Tables

5/8" Uponor PEX-a — 50% Propylene Glycol — Feet of Head per Foot of Tubing

Velocity (ft./sec.)	GPM	40°F 4°C	45°F 7°C	50°F 10°C	55°F 13°C	60°F 16°C	65°F 18°C	70°F 21°C	80°F 27°C	90°F 32°C	100°F 38°C	110°F 43°C	120°F 49°C	130°F 54°C	140°F 60°C	150°F 66°C	160°F 71°C	170°F 77°C	180°F 82°C	190°F 88°C	200°F 93°C
3.9	3.15	0.28307	0.27043	0.25676	0.24653	0.23551	0.22710	0.21807	0.20363	0.19146	0.18118	0.17242	0.16482	0.15822	0.15241	0.14733	0.14288	0.13875	0.13503	0.13198	0.12900
4.0	3.23	0.29520	0.28207	0.26786	0.25722	0.24576	0.23701	0.22762	0.21259	0.19992	0.18922	0.18010	0.17219	0.16532	0.15926	0.15397	0.14933	0.14503	0.14116	0.13798	0.13487
4.1	3.31	0.30755	0.29391	0.27915	0.26810	0.25619	0.24710	0.23734	0.22172	0.20855	0.19742	0.18793	0.17970	0.17255	0.16624	0.16074	0.15591	0.15143	0.14740	0.14409	0.14085
4.2	3.39	0.32010	0.30595	0.29063	0.27917	0.26680	0.25737	0.24723	0.23101	0.21733	0.20576	0.19590	0.18735	0.17991	0.17335	0.16763	0.16261	0.15795	0.15376	0.15031	0.14695
4.3	3.47	0.33285	0.31819	0.30231	0.29042	0.27760	0.26781	0.25729	0.24046	0.22626	0.21426	0.20401	0.19513	0.18741	0.18060	0.17465	0.16943	0.16460	0.16023	0.15666	0.15316
4.4	3.55	0.34582	0.33063	0.31418	0.30186	0.28857	0.27843	0.26753	0.25007	0.23535	0.22290	0.21227	0.20305	0.19504	0.18797	0.18180	0.17638	0.17136	0.16683	0.16311	0.15948

Recommended Head Loss Design Range

Sizing in this region will lead to excessive head loss conditions.

Appendix D

Uponor PEX-a Hydronic Friction Loss Tables

3/4" Uponor PEX-a — 100% Water — Feet of Head per Foot of Tubing

Velocity (ft./sec.)	GPM	40°F 4°C	45°F 7°C	50°F 10°C	55°F 13°C	60°F 16°C	65°F 18°C	70°F 21°C	80°F 27°C	90°F 32°C	100°F 38°C	110°F 43°C	120°F 49°C	130°F 54°C	140°F 60°C	150°F 66°C	160°F 71°C	170°F 77°C	180°F 82°C	190°F 88°C	200°F 93°C
3.8	4.19	0.12359	0.11794	0.11155	0.10953	0.10741	0.10566	0.10383	0.10069	0.09791	0.09543	0.09322	0.09121	0.08939	0.08773	0.08621	0.08482	0.08351	0.08233	0.08123	0.08020
3.9	4.30	0.12929	0.12340	0.11674	0.11463	0.11241	0.11059	0.10868	0.10540	0.10250	0.09991	0.09760	0.09550	0.09360	0.09188	0.09028	0.08883	0.08746	0.08623	0.08509	0.08401
4.0	4.41	0.13511	0.12897	0.12203	0.11983	0.11752	0.11562	0.11363	0.11021	0.10719	0.10449	0.10208	0.09989	0.09791	0.09611	0.09444	0.09293	0.09150	0.09022	0.08902	0.08790
4.1	4.52	0.14103	0.13465	0.12742	0.12513	0.12272	0.12074	0.11867	0.11511	0.11196	0.10915	0.10664	0.10436	0.10230	0.10042	0.09869	0.09711	0.09562	0.09429	0.09304	0.09187
4.2	4.63	0.14707	0.14043	0.13291	0.13053	0.12803	0.12596	0.12381	0.12010	0.11683	0.11391	0.11129	0.10892	0.10677	0.10482	0.10302	0.10137	0.09983	0.09843	0.09713	0.09592
4.3	4.74	0.15322	0.14632	0.13850	0.13603	0.13343	0.13129	0.12904	0.12519	0.12179	0.11875	0.11603	0.11356	0.11133	0.10930	0.10743	0.10572	0.10411	0.10266	0.10131	0.10005
4.4	4.85	0.15947	0.15231	0.14420	0.14163	0.13893	0.13670	0.13438	0.13038	0.12684	0.12368	0.12086	0.11829	0.11597	0.11387	0.11192	0.11014	0.10847	0.10696	0.10556	0.10425
4.5	4.96	0.16584	0.15841	0.14999	0.14733	0.14452	0.14222	0.13980	0.13565	0.13198	0.12870	0.12578	0.12311	0.12070	0.11852	0.11649	0.11465	0.11291	0.11135	0.10989	0.10853
4.6	5.07	0.17231	0.16462	0.15589	0.15312	0.15022	0.14783	0.14532	0.14102	0.13722	0.13381	0.13078	0.12801	0.12552	0.12325	0.12115	0.11924	0.11744	0.11581	0.11430	0.11289
4.7	5.18	0.17890	0.17092	0.16188	0.15902	0.15601	0.15353	0.15094	0.14648	0.14254	0.13901	0.13587	0.13300	0.13041	0.12806	0.12589	0.12391	0.12204	0.12036	0.11879	0.11733
4.8	5.29	0.18558	0.17733	0.16798	0.16501	0.16190	0.15933	0.15664	0.15203	0.14795	0.14430	0.14104	0.13807	0.13539	0.13296	0.13070	0.12865	0.12672	0.12498	0.12336	0.12184
4.9	5.40	0.19238	0.18385	0.17417	0.17110	0.16788	0.16523	0.16245	0.15767	0.15345	0.14967	0.14630	0.14323	0.14046	0.13794	0.13560	0.13348	0.13148	0.12968	0.12800	0.12643
5.0	5.51	0.19928	0.19046	0.18046	0.17729	0.17396	0.17121	0.16834	0.16340	0.15904	0.15513	0.15165	0.14847	0.14560	0.14300	0.14058	0.13839	0.13632	0.13445	0.13272	0.13109
5.1	5.62	0.20629	0.19718	0.18685	0.18357	0.18013	0.17730	0.17433	0.16923	0.16472	0.16068	0.15708	0.15380	0.15083	0.14814	0.14564	0.14337	0.14123	0.13931	0.13751	0.13584
5.2	5.73	0.21340	0.20400	0.19334	0.18995	0.18640	0.18347	0.18041	0.17514	0.17048	0.16631	0.16259	0.15921	0.15614	0.15336	0.15078	0.14844	0.14623	0.14424	0.14239	0.14065
5.3	5.84	0.22062	0.21092	0.19992	0.19643	0.19276	0.18974	0.18658	0.18114	0.17634	0.17203	0.16819	0.16470	0.16154	0.15866	0.15600	0.15358	0.15130	0.14925	0.14733	0.14555
5.4	5.95	0.22795	0.21795	0.20660	0.20300	0.19922	0.19611	0.19284	0.18723	0.18228	0.17784	0.17388	0.17027	0.16701	0.16405	0.16130	0.15881	0.15645	0.15433	0.15236	0.15051
5.5	6.06	0.23538	0.22507	0.21338	0.20967	0.20577	0.20256	0.19920	0.19342	0.18831	0.18373	0.17965	0.17593	0.17257	0.16951	0.16668	0.16411	0.16168	0.15949	0.15746	0.15556
5.6	6.17	0.24291	0.23230	0.22025	0.21643	0.21242	0.20911	0.20564	0.19969	0.19442	0.18971	0.18550	0.18167	0.17820	0.17505	0.17214	0.16949	0.16699	0.16473	0.16263	0.16067
5.7	6.28	0.25054	0.23962	0.22722	0.22329	0.21915	0.21575	0.21218	0.20605	0.20063	0.19577	0.19144	0.18749	0.18392	0.18068	0.17768	0.17495	0.17237	0.17005	0.16789	0.16587
5.8	6.39	0.25828	0.24704	0.23428	0.23024	0.22598	0.22248	0.21881	0.21250	0.20692	0.20192	0.19746	0.19339	0.18972	0.18638	0.18329	0.18048	0.17783	0.17544	0.17321	0.17113
5.9	6.50	0.26613	0.25457	0.24144	0.23728	0.23291	0.22930	0.22553	0.21903	0.21329	0.20815	0.20356	0.19938	0.19560	0.19216	0.18899	0.18609	0.18336	0.18090	0.17861	0.17647

Recommended Head Loss Design Range

Sizing in this region will lead to excessive head loss conditions.

Appendix D

Uponor PEX-a Hydronic Friction Loss Tables

3/4" Uponor PEX-a — 30% Propylene Glycol — Feet of Head per Foot of Tubing

Velocity (ft./sec.)	GPM	40°F 4°C	45°F 7°C	50°F 10°C	55°F 13°C	60°F 16°C	65°F 18°C	70°F 21°C	80°F 27°C	90°F 32°C	100°F 38°C	110°F 43°C	120°F 49°C	130°F 54°C	140°F 60°C	150°F 66°C	160°F 71°C	170°F 77°C	180°F 82°C	190°F 88°C	200°F 93°C
3.9	4.30	0.17335	0.16768	0.16159	0.15685	0.15178	0.14768	0.14331	0.13619	0.13005	0.12474	0.12008	0.11612	0.11255	0.10930	0.10670	0.10415	0.10179	0.09983	0.09789	0.09645
4.0	4.41	0.18099	0.17508	0.16874	0.16381	0.15853	0.15426	0.14971	0.14230	0.13590	0.13037	0.12551	0.12138	0.11766	0.11428	0.11156	0.10890	0.10645	0.10440	0.10238	0.10088
4.1	4.52	0.18876	0.18262	0.17603	0.17090	0.16541	0.16097	0.15623	0.14852	0.14186	0.13610	0.13105	0.12674	0.12287	0.11935	0.11652	0.11375	0.11119	0.10906	0.10695	0.10539
4.2	4.63	0.19667	0.19029	0.18345	0.17811	0.17241	0.16779	0.16287	0.15485	0.14793	0.14194	0.13668	0.13221	0.12818	0.12452	0.12157	0.11869	0.11603	0.11381	0.11162	0.10999
4.3	4.74	0.20472	0.19810	0.19099	0.18546	0.17954	0.17474	0.16963	0.16130	0.15411	0.14789	0.14243	0.13777	0.13359	0.12978	0.12672	0.12372	0.12096	0.11865	0.11637	0.11468
4.4	4.85	0.21291	0.20604	0.19867	0.19293	0.18679	0.18181	0.17651	0.16787	0.16040	0.15394	0.14827	0.14344	0.13910	0.13514	0.13196	0.12885	0.12597	0.12358	0.12121	0.11946
4.5	4.96	0.22123	0.21412	0.20648	0.20053	0.19416	0.18900	0.18350	0.17454	0.16680	0.16010	0.15422	0.14921	0.14470	0.14059	0.13730	0.13406	0.13108	0.12860	0.12614	0.12432
4.6	5.07	0.22969	0.22233	0.21441	0.20825	0.20165	0.19631	0.19062	0.18133	0.17331	0.16637	0.16027	0.15507	0.15040	0.14614	0.14273	0.13937	0.13628	0.13370	0.13115	0.12927
4.7	5.18	0.23828	0.23066	0.22248	0.21610	0.20927	0.20374	0.19785	0.18823	0.17992	0.17274	0.16642	0.16104	0.15620	0.15179	0.14825	0.14477	0.14157	0.13890	0.13625	0.13430
4.8	5.29	0.24701	0.23913	0.23067	0.22407	0.21701	0.21129	0.20519	0.19525	0.18665	0.17921	0.17267	0.16710	0.16209	0.15753	0.15386	0.15026	0.14695	0.14418	0.14144	0.13942
4.9	5.40	0.25587	0.24774	0.23899	0.23217	0.22487	0.21896	0.21265	0.20237	0.19348	0.18579	0.17903	0.17327	0.16808	0.16336	0.15957	0.15584	0.15241	0.14955	0.14672	0.14462
5.0	5.51	0.26487	0.25647	0.24743	0.24039	0.23285	0.22675	0.22023	0.20961	0.20042	0.19247	0.18548	0.17953	0.17417	0.16928	0.16536	0.16151	0.15797	0.15501	0.15208	0.14991
5.1	5.62	0.27400	0.26533	0.25600	0.24873	0.24095	0.23465	0.22792	0.21695	0.20747	0.19926	0.19204	0.18588	0.18035	0.17530	0.17125	0.16727	0.16361	0.16055	0.15752	0.15528
5.2	5.73	0.28326	0.27431	0.26470	0.25720	0.24917	0.24267	0.23573	0.22441	0.21462	0.20615	0.19869	0.19234	0.18663	0.18141	0.17723	0.17312	0.16934	0.16618	0.16305	0.16074
5.3	5.84	0.29265	0.28343	0.27352	0.26579	0.25751	0.25081	0.24365	0.23197	0.22188	0.21314	0.20544	0.19889	0.19300	0.18762	0.18330	0.17906	0.17515	0.17189	0.16867	0.16628

Recommended Head Loss Design Range

Sizing in this region will lead to excessive head loss conditions.

Appendix D

Uponor PEX-a Hydronic Friction Loss Tables

3/4" Uponor PEX-a — 40% Propylene Glycol — Feet of Head per Foot of Tubing

Velocity (ft./sec.)	GPM	40°F 4°C	45°F 7°C	50°F 10°C	55°F 13°C	60°F 16°C	65°F 18°C	70°F 21°C	80°F 27°C	90°F 32°C	100°F 38°C	110°F 43°C	120°F 49°C	130°F 54°C	140°F 60°C	150°F 66°C	160°F 71°C	170°F 77°C	180°F 82°C	190°F 88°C	200°F 93°C
0.5	0.55	0.00711	0.00673	0.00632	0.00601	0.00569	0.00545	0.00520	0.00479	0.00446	0.00418	0.00395	0.00375	0.00358	0.00343	0.00330	0.00320	0.00309	0.00301	0.00292	0.00286
0.6	0.66	0.00948	0.00898	0.00845	0.00805	0.00764	0.00732	0.00699	0.00646	0.00602	0.00566	0.00535	0.00508	0.00486	0.00466	0.00449	0.00435	0.00421	0.00410	0.00399	0.00390
0.7	0.77	0.01211	0.01149	0.01082	0.01033	0.00980	0.00941	0.00899	0.00832	0.00777	0.00731	0.00692	0.00658	0.00630	0.00604	0.00583	0.00565	0.00547	0.00534	0.00519	0.00508
0.8	0.88	0.01499	0.01423	0.01342	0.01282	0.01218	0.01170	0.01119	0.01037	0.00969	0.00914	0.00866	0.00824	0.00789	0.00758	0.00732	0.00709	0.00687	0.00671	0.00652	0.00639
0.9	0.99	0.01811	0.01721	0.01624	0.01553	0.01477	0.01419	0.01358	0.01261	0.01180	0.01113	0.01056	0.01005	0.00963	0.00926	0.00894	0.00867	0.00840	0.00821	0.00798	0.00782
1.0	1.10	0.02146	0.02041	0.01928	0.01845	0.01756	0.01688	0.01616	0.01502	0.01407	0.01328	0.01261	0.01202	0.01152	0.01108	0.01071	0.01039	0.01007	0.00983	0.00957	0.00938
1.1	1.21	0.02504	0.02382	0.02252	0.02156	0.02054	0.01976	0.01893	0.01761	0.01651	0.01559	0.01481	0.01413	0.01355	0.01303	0.01260	0.01223	0.01186	0.01159	0.01128	0.01106
1.2	1.32	0.02883	0.02745	0.02597	0.02488	0.02371	0.02282	0.02187	0.02036	0.01910	0.01806	0.01716	0.01638	0.01572	0.01513	0.01463	0.01420	0.01378	0.01346	0.01311	0.01285
1.3	1.43	0.03284	0.03129	0.02962	0.02838	0.02706	0.02606	0.02499	0.02328	0.02186	0.02067	0.01966	0.01877	0.01802	0.01735	0.01678	0.01630	0.01582	0.01546	0.01506	0.01477
1.4	1.54	0.03706	0.03532	0.03346	0.03208	0.03060	0.02948	0.02828	0.02637	0.02477	0.02344	0.02230	0.02130	0.02045	0.01970	0.01907	0.01852	0.01798	0.01757	0.01712	0.01679
1.5	1.65	0.04148	0.03956	0.03749	0.03596	0.03432	0.03307	0.03174	0.02961	0.02783	0.02635	0.02508	0.02397	0.02302	0.02218	0.02147	0.02086	0.02026	0.01981	0.01930	0.01893
1.6	1.76	0.04611	0.04399	0.04171	0.04002	0.03821	0.03683	0.03536	0.03301	0.03104	0.02940	0.02800	0.02677	0.02572	0.02479	0.02400	0.02333	0.02265	0.02215	0.02159	0.02118
1.7	1.87	0.05093	0.04861	0.04611	0.04426	0.04227	0.04076	0.03915	0.03656	0.03440	0.03260	0.03105	0.02969	0.02854	0.02752	0.02665	0.02590	0.02516	0.02461	0.02399	0.02354
1.8	1.98	0.05595	0.05342	0.05069	0.04867	0.04651	0.04486	0.04309	0.04027	0.03790	0.03593	0.03424	0.03275	0.03149	0.03037	0.02942	0.02860	0.02779	0.02718	0.02650	0.02601
1.9	2.09	0.06116	0.05841	0.05545	0.05326	0.05091	0.04911	0.04720	0.04412	0.04155	0.03941	0.03756	0.03594	0.03457	0.03334	0.03230	0.03141	0.03052	0.02986	0.02912	0.02858
2.0	2.20	0.06656	0.06359	0.06039	0.05802	0.05547	0.05353	0.05145	0.04813	0.04534	0.04301	0.04102	0.03926	0.03776	0.03643	0.03530	0.03434	0.03337	0.03265	0.03185	0.03126
2.1	2.31	0.07214	0.06895	0.06550	0.06295	0.06020	0.05811	0.05587	0.05228	0.04927	0.04676	0.04460	0.04269	0.04108	0.03964	0.03842	0.03737	0.03633	0.03555	0.03468	0.03404
2.2	2.43	0.07791	0.07448	0.07078	0.06804	0.06509	0.06284	0.06043	0.05657	0.05334	0.05063	0.04831	0.04626	0.04452	0.04296	0.04165	0.04052	0.03939	0.03856	0.03762	0.03693
2.3	2.54	0.08387	0.08020	0.07624	0.07330	0.07014	0.06773	0.06515	0.06101	0.05754	0.05464	0.05214	0.04994	0.04807	0.04640	0.04499	0.04378	0.04257	0.04167	0.04066	0.03992
2.4	2.65	0.09000	0.08609	0.08186	0.07872	0.07535	0.07277	0.07002	0.06559	0.06188	0.05877	0.05610	0.05375	0.05174	0.04996	0.04845	0.04715	0.04585	0.04488	0.04380	0.04301
2.5	2.76	0.09631	0.09215	0.08764	0.08430	0.08071	0.07797	0.07503	0.07031	0.06635	0.06304	0.06019	0.05767	0.05553	0.05363	0.05201	0.05062	0.04924	0.04820	0.04705	0.04620
2.6	2.87	0.10280	0.09838	0.09359	0.09005	0.08623	0.08331	0.08019	0.07517	0.07096	0.06743	0.06440	0.06172	0.05944	0.05741	0.05569	0.05421	0.05273	0.05163	0.05039	0.04949
2.7	2.98	0.10946	0.10478	0.09971	0.09595	0.09190	0.08881	0.08549	0.08017	0.07569	0.07195	0.06873	0.06588	0.06346	0.06130	0.05947	0.05790	0.05632	0.05515	0.05384	0.05288
2.8	3.09	0.11630	0.11134	0.10598	0.10200	0.09772	0.09445	0.09094	0.08530	0.08056	0.07659	0.07318	0.07016	0.06759	0.06530	0.06336	0.06169	0.06002	0.05878	0.05739	0.05637
2.9	3.20	0.12331	0.11808	0.11242	0.10822	0.10369	0.10024	0.09653	0.09057	0.08556	0.08136	0.07775	0.07456	0.07184	0.06941	0.06736	0.06559	0.06383	0.06251	0.06103	0.05996
3.0	3.31	0.13048	0.12498	0.11901	0.11459	0.10982	0.10617	0.10226	0.09598	0.09069	0.08626	0.08244	0.07907	0.07620	0.07364	0.07147	0.06960	0.06773	0.06634	0.06478	0.06364
3.1	3.42	0.13783	0.13204	0.12577	0.12111	0.11609	0.11225	0.10813	0.10151	0.09594	0.09127	0.08725	0.08369	0.08067	0.07797	0.07568	0.07371	0.07174	0.07027	0.06862	0.06742
3.2	3.53	0.14535	0.13926	0.13267	0.12778	0.12250	0.11847	0.11414	0.10718	0.10132	0.09641	0.09218	0.08843	0.08525	0.08240	0.08000	0.07792	0.07584	0.07430	0.07256	0.07129
3.3	3.64	0.15302	0.14665	0.13974	0.13460	0.12907	0.12483	0.12029	0.11298	0.10683	0.10167	0.09722	0.09329	0.08994	0.08695	0.08442	0.08223	0.08005	0.07842	0.07660	0.07526
3.4	3.75	0.16087	0.15419	0.14695	0.14157	0.13577	0.13133	0.12657	0.11891	0.11246	0.10704	0.10238	0.09825	0.09474	0.09160	0.08894	0.08665	0.08435	0.08265	0.08073	0.07933
3.5	3.86	0.16888	0.16189	0.15432	0.14869	0.14262	0.13798	0.13300	0.12497	0.11821	0.11254	0.10765	0.10333	0.09965	0.09635	0.09357	0.09116	0.08876	0.08697	0.08496	0.08349
3.6	3.97	0.17705	0.16975	0.16184	0.15596	0.14962	0.14476	0.13955	0.13116	0.12409	0.11816	0.11304	0.10852	0.10466	0.10121	0.09830	0.09578	0.09326	0.09139	0.08928	0.08774
3.7	4.08	0.18538	0.17777	0.16951	0.16337	0.15675	0.15168	0.14624	0.13748	0.13009	0.12389	0.11855	0.11382	0.10979	0.10618	0.10313	0.10050	0.09786	0.09590	0.09370	0.09209
3.8	4.19	0.19387	0.18594	0.17733	0.17093	0.16403	0.15874	0.15307	0.14393	0.13621	0.12974	0.12416	0.11922	0.11502	0.11125	0.10806	0.10531	0.10256	0.10051	0.09821	0.09652

Continued on next page

Recommended Head Loss Design Range

Sizing in this region will lead to excessive head loss conditions.

Appendix D

Uponor PEX-a Hydronic Friction Loss Tables

3/4" Uponor PEX-a — 40% Propylene Glycol — Feet of Head per Foot of Tubing

Velocity (ft./sec.)	GPM	40°F 4°C	45°F 7°C	50°F 10°C	55°F 13°C	60°F 16°C	65°F 18°C	70°F 21°C	80°F 27°C	90°F 32°C	100°F 38°C	110°F 43°C	120°F 49°C	130°F 54°C	140°F 60°C	150°F 66°C	160°F 71°C	170°F 77°C	180°F 82°C	190°F 88°C	200°F 93°C
3.9	4.30	0.20252	0.19426	0.18530	0.17863	0.17144	0.16594	0.16002	0.15050	0.14246	0.13571	0.12989	0.12474	0.12035	0.11642	0.11310	0.11023	0.10735	0.10522	0.10281	0.10106
4.0	4.41	0.21133	0.20274	0.19342	0.18648	0.17900	0.17327	0.16711	0.15719	0.14882	0.14180	0.13573	0.13036	0.12579	0.12169	0.11823	0.11524	0.11224	0.11002	0.10751	0.10568
4.1	4.52	0.22030	0.21137	0.20168	0.19447	0.18669	0.18073	0.17433	0.16402	0.15531	0.14799	0.14168	0.13610	0.13134	0.12707	0.12346	0.12035	0.11723	0.11491	0.11230	0.11039
4.2	4.63	0.22942	0.22015	0.21009	0.20260	0.19452	0.18833	0.18168	0.17096	0.16191	0.15431	0.14775	0.14194	0.13699	0.13255	0.12880	0.12556	0.12231	0.11990	0.11718	0.11520
4.3	4.74	0.23870	0.22908	0.21865	0.21088	0.20249	0.19606	0.18916	0.17803	0.16863	0.16074	0.15392	0.14789	0.14274	0.13813	0.13423	0.13086	0.12749	0.12498	0.12215	0.12009
4.4	4.85	0.24813	0.23816	0.22735	0.21929	0.21060	0.20393	0.19677	0.18523	0.17547	0.16728	0.16020	0.15394	0.14860	0.14381	0.13976	0.13626	0.13276	0.13015	0.12722	0.12508
4.5	4.96	0.25771	0.24739	0.23619	0.22785	0.21884	0.21193	0.20451	0.19254	0.18243	0.17393	0.16660	0.16010	0.15456	0.14959	0.14539	0.14176	0.13812	0.13542	0.13237	0.13015
4.6	5.07	0.26745	0.25677	0.24518	0.23654	0.22721	0.22006	0.21237	0.19998	0.18950	0.18070	0.17310	0.16636	0.16062	0.15547	0.15112	0.14735	0.14358	0.14078	0.13762	0.13531
4.7	5.18	0.27734	0.26630	0.25431	0.24537	0.23572	0.22832	0.22037	0.20754	0.19669	0.18758	0.17971	0.17273	0.16678	0.16145	0.15694	0.15304	0.14913	0.14623	0.14296	0.14057
4.8	5.29	0.28739	0.27597	0.26358	0.25434	0.24436	0.23671	0.22849	0.21522	0.20400	0.19457	0.18642	0.17921	0.17305	0.16753	0.16286	0.15882	0.15478	0.15177	0.14838	0.14591
4.9	5.40	0.29758	0.28579	0.27299	0.26344	0.25313	0.24523	0.23673	0.22302	0.21142	0.20167	0.19325	0.18578	0.17942	0.17371	0.16887	0.16470	0.16052	0.15740	0.15390	0.15134
5.0	5.51	0.30792	0.29575	0.28254	0.27268	0.26204	0.25388	0.24510	0.23094	0.21896	0.20889	0.20018	0.19247	0.18588	0.17998	0.17499	0.17067	0.16634	0.16313	0.15950	0.15685
5.1	5.62	0.31841	0.30586	0.29223	0.28206	0.27108	0.26265	0.25360	0.23898	0.22661	0.21621	0.20722	0.19925	0.19245	0.18636	0.18120	0.17673	0.17227	0.16894	0.16520	0.16246

Recommended Head Loss Design Range

Sizing in this region will lead to excessive head loss conditions.

Appendix D

Uponor PEX-a Hydronic Friction Loss Tables

3/4" Uponor PEX-a — 50% Propylene Glycol — Feet of Head per Foot of Tubing

Velocity (ft./sec.)	GPM	40°F 4°C	45°F 7°C	50°F 10°C	55°F 13°C	60°F 16°C	65°F 18°C	70°F 21°C	80°F 27°C	90°F 32°C	100°F 38°C	110°F 43°C	120°F 49°C	130°F 54°C	140°F 60°C	150°F 66°C	160°F 71°C	170°F 77°C	180°F 82°C	190°F 88°C	200°F 93°C
0.5	0.55	0.00843	0.00793	0.00741	0.00702	0.00661	0.00630	0.00598	0.00547	0.00505	0.00470	0.00441	0.00416	0.00395	0.00377	0.00361	0.00347	0.00334	0.00323	0.00314	0.00305
0.6	0.66	0.01118	0.01054	0.00987	0.00936	0.00883	0.00843	0.00801	0.00734	0.00679	0.00634	0.00595	0.00563	0.00535	0.00510	0.00489	0.00471	0.00454	0.00439	0.00427	0.00415
0.7	0.77	0.01423	0.01344	0.01259	0.01197	0.01130	0.01080	0.01027	0.00943	0.00874	0.00817	0.00768	0.00727	0.00692	0.00661	0.00634	0.00611	0.00590	0.00571	0.00555	0.00540
0.8	0.88	0.01756	0.01660	0.01557	0.01481	0.01401	0.01340	0.01275	0.01173	0.01089	0.01018	0.00959	0.00909	0.00865	0.00827	0.00795	0.00766	0.00740	0.00716	0.00697	0.00678
0.9	0.99	0.02115	0.02001	0.01880	0.01790	0.01694	0.01622	0.01545	0.01423	0.01322	0.01238	0.01168	0.01107	0.01055	0.01009	0.00970	0.00935	0.00904	0.00875	0.00852	0.00830
1.0	1.10	0.02500	0.02368	0.02226	0.02121	0.02009	0.01925	0.01835	0.01693	0.01574	0.01476	0.01393	0.01321	0.01260	0.01206	0.01160	0.01119	0.01082	0.01048	0.01021	0.00994
1.1	1.21	0.02910	0.02758	0.02596	0.02475	0.02346	0.02249	0.02145	0.01981	0.01844	0.01730	0.01634	0.01551	0.01480	0.01418	0.01364	0.01317	0.01273	0.01234	0.01203	0.01172
1.2	1.32	0.03345	0.03172	0.02988	0.02851	0.02704	0.02593	0.02475	0.02288	0.02132	0.02002	0.01891	0.01797	0.01715	0.01644	0.01582	0.01528	0.01478	0.01433	0.01397	0.01361
1.3	1.43	0.03803	0.03609	0.03402	0.03247	0.03082	0.02957	0.02824	0.02613	0.02436	0.02289	0.02165	0.02057	0.01965	0.01884	0.01814	0.01752	0.01696	0.01645	0.01603	0.01563
1.4	1.54	0.04285	0.04069	0.03837	0.03665	0.03481	0.03341	0.03192	0.02955	0.02758	0.02593	0.02453	0.02333	0.02229	0.02138	0.02059	0.01990	0.01926	0.01869	0.01822	0.01776
1.5	1.65	0.04789	0.04550	0.04294	0.04103	0.03898	0.03743	0.03578	0.03315	0.03096	0.02912	0.02756	0.02622	0.02507	0.02405	0.02317	0.02240	0.02169	0.02105	0.02053	0.02002
1.6	1.76	0.05316	0.05053	0.04771	0.04561	0.04335	0.04165	0.03982	0.03692	0.03450	0.03247	0.03075	0.02926	0.02798	0.02686	0.02588	0.02503	0.02424	0.02353	0.02295	0.02239
1.7	1.87	0.05865	0.05577	0.05268	0.05038	0.04791	0.04604	0.04404	0.04086	0.03820	0.03597	0.03408	0.03245	0.03104	0.02980	0.02872	0.02778	0.02691	0.02613	0.02549	0.02487
1.8	1.98	0.06435	0.06122	0.05786	0.05535	0.05266	0.05062	0.04844	0.04496	0.04206	0.03962	0.03755	0.03577	0.03422	0.03287	0.03169	0.03066	0.02971	0.02885	0.02815	0.02746
1.9	2.09	0.07027	0.06688	0.06323	0.06051	0.05759	0.05537	0.05300	0.04923	0.04607	0.04342	0.04117	0.03922	0.03754	0.03606	0.03478	0.03366	0.03262	0.03168	0.03092	0.03017
2.0	2.20	0.07640	0.07274	0.06879	0.06585	0.06270	0.06031	0.05774	0.05366	0.05024	0.04736	0.04492	0.04282	0.04099	0.03939	0.03800	0.03677	0.03565	0.03463	0.03380	0.03299
2.1	2.31	0.08273	0.07879	0.07455	0.07139	0.06799	0.06541	0.06265	0.05825	0.05455	0.05145	0.04882	0.04654	0.04457	0.04284	0.04133	0.04001	0.03879	0.03769	0.03679	0.03592
2.2	2.43	0.08927	0.08504	0.08049	0.07710	0.07346	0.07069	0.06772	0.06299	0.05902	0.05568	0.05285	0.05040	0.04828	0.04641	0.04479	0.04337	0.04205	0.04087	0.03990	0.03895
2.3	2.54	0.09600	0.09149	0.08663	0.08300	0.07910	0.07613	0.07295	0.06789	0.06364	0.06006	0.05702	0.05439	0.05211	0.05011	0.04836	0.04684	0.04542	0.04415	0.04311	0.04209
2.4	2.65	0.10294	0.09813	0.09295	0.08907	0.08491	0.08175	0.07835	0.07294	0.06840	0.06457	0.06132	0.05851	0.05607	0.05393	0.05206	0.05042	0.04891	0.04754	0.04643	0.04534
2.5	2.76	0.11008	0.10496	0.09945	0.09533	0.09090	0.08753	0.08391	0.07815	0.07330	0.06923	0.06576	0.06276	0.06015	0.05786	0.05587	0.05412	0.05250	0.05105	0.04985	0.04869
2.6	2.87	0.11741	0.11198	0.10613	0.10175	0.09705	0.09347	0.08963	0.08350	0.07835	0.07402	0.07032	0.06713	0.06436	0.06192	0.05980	0.05793	0.05621	0.05466	0.05339	0.05214
2.7	2.98	0.12493	0.11919	0.11299	0.10836	0.10337	0.09958	0.09551	0.08901	0.08355	0.07894	0.07502	0.07163	0.06869	0.06610	0.06384	0.06186	0.06003	0.05838	0.05702	0.05570
2.8	3.09	0.13264	0.12658	0.12002	0.11513	0.10986	0.10584	0.10154	0.09466	0.08888	0.08400	0.07985	0.07626	0.07314	0.07039	0.06800	0.06590	0.06395	0.06220	0.06077	0.05936
2.9	3.20	0.14054	0.13415	0.12724	0.12207	0.11651	0.11227	0.10773	0.10046	0.09435	0.08920	0.08481	0.08101	0.07771	0.07480	0.07227	0.07004	0.06799	0.06613	0.06461	0.06313
3.0	3.31	0.14863	0.14190	0.13462	0.12918	0.12333	0.11886	0.11407	0.10641	0.09996	0.09452	0.08989	0.08588	0.08239	0.07933	0.07665	0.07430	0.07213	0.07017	0.06856	0.06699
3.1	3.42	0.15691	0.14983	0.14218	0.13646	0.13030	0.12560	0.12056	0.11250	0.10571	0.09998	0.09510	0.09087	0.08720	0.08397	0.08114	0.07867	0.07637	0.07431	0.07261	0.07096
3.2	3.53	0.16537	0.15794	0.14991	0.14391	0.13744	0.13250	0.12720	0.11873	0.11160	0.10557	0.10044	0.09599	0.09212	0.08872	0.08575	0.08314	0.08073	0.07855	0.07677	0.07502
3.3	3.64	0.17401	0.16623	0.15781	0.15152	0.14473	0.13956	0.13400	0.12511	0.11762	0.11129	0.10590	0.10123	0.09717	0.09359	0.09047	0.08772	0.08519	0.08290	0.08102	0.07919
3.4	3.75	0.18284	0.17469	0.16588	0.15929	0.15219	0.14676	0.14094	0.13163	0.12377	0.11714	0.11149	0.10658	0.10232	0.09857	0.09529	0.09241	0.08975	0.08735	0.08538	0.08345
3.5	3.86	0.19184	0.18333	0.17412	0.16723	0.15980	0.15412	0.14803	0.13828	0.13006	0.12312	0.11720	0.11206	0.10759	0.10366	0.10023	0.09721	0.09441	0.09190	0.08983	0.08781
3.6	3.97	0.20103	0.19214	0.18252	0.17532	0.16756	0.16163	0.15527	0.14508	0.13649	0.12922	0.12303	0.11765	0.11298	0.10886	0.10527	0.10211	0.09918	0.09655	0.09438	0.09227
3.7	4.08	0.21039	0.20112	0.19109	0.18358	0.17548	0.16930	0.16265	0.15202	0.14304	0.13545	0.12898	0.12337	0.11848	0.11418	0.11042	0.10712	0.10406	0.10130	0.09903	0.09682
3.8	4.19	0.21992	0.21027	0.19982	0.19200	0.18356	0.17711	0.17018	0.15909	0.14973	0.14181	0.13506	0.12919	0.12410	0.11960	0.11568	0.11223	0.10903	0.10615	0.10378	0.10147

Continued on next page

Sizing in this region will lead to excessive head loss conditions.

Recommended Head Loss Design Range

Appendix D

Uponor PEX-a Hydronic Friction Loss Tables

3/4" Uponor PEX-a — 50% Propylene Glycol — Feet of Head per Foot of Tubing

Velocity (ft./sec.)	GPM	40°F 4°C	45°F 7°C	50°F 10°C	55°F 13°C	60°F 16°C	65°F 18°C	70°F 21°C	80°F 27°C	90°F 32°C	100°F 38°C	110°F 43°C	120°F 49°C	130°F 54°C	140°F 60°C	150°F 66°C	160°F 71°C	170°F 77°C	180°F 82°C	190°F 88°C	200°F 93°C
3.9	4.30	0.22963	0.21959	0.20872	0.20057	0.19178	0.18507	0.17785	0.16630	0.15654	0.14829	0.14125	0.13514	0.12982	0.12513	0.12104	0.11744	0.11411	0.11110	0.10863	0.10622
4.0	4.41	0.23952	0.22908	0.21777	0.20930	0.20016	0.19318	0.18567	0.17364	0.16349	0.15490	0.14756	0.14120	0.13566	0.13077	0.12651	0.12276	0.11928	0.11615	0.11358	0.11106
4.1	4.52	0.24958	0.23874	0.22699	0.21819	0.20869	0.20143	0.19363	0.18112	0.17056	0.16163	0.15400	0.14737	0.14161	0.13652	0.13208	0.12818	0.12456	0.12130	0.11862	0.11600
4.2	4.63	0.25981	0.24856	0.23637	0.22723	0.21737	0.20983	0.20173	0.18874	0.17777	0.16848	0.16055	0.15366	0.14767	0.14238	0.13776	0.13370	0.12994	0.12654	0.12376	0.12103
4.3	4.74	0.27021	0.25855	0.24590	0.23643	0.22620	0.21838	0.20997	0.19649	0.18510	0.17546	0.16722	0.16007	0.15384	0.14835	0.14355	0.13933	0.13542	0.13189	0.12899	0.12616
4.4	4.85	0.28078	0.26870	0.25560	0.24578	0.23517	0.22707	0.21835	0.20437	0.19255	0.18255	0.17401	0.16658	0.16012	0.15442	0.14943	0.14505	0.14099	0.13733	0.13432	0.13138
4.5	4.96	0.29152	0.27901	0.26545	0.25528	0.24430	0.23590	0.22687	0.21238	0.20014	0.18977	0.18091	0.17321	0.16651	0.16059	0.15543	0.15088	0.14667	0.14287	0.13974	0.13669
4.6	5.07	0.30242	0.28949	0.27545	0.26493	0.25357	0.24488	0.23553	0.22053	0.20785	0.19711	0.18793	0.17995	0.17301	0.16688	0.16152	0.15681	0.15244	0.14850	0.14526	0.14209
4.7	5.18	0.31350	0.30012	0.28562	0.27474	0.26298	0.25399	0.24432	0.22880	0.21568	0.20457	0.19506	0.18680	0.17961	0.17326	0.16772	0.16284	0.15831	0.15423	0.15087	0.14759
4.8	5.29	0.32474	0.31092	0.29593	0.28469	0.27254	0.26325	0.25325	0.23721	0.22364	0.21214	0.20231	0.19377	0.18633	0.17976	0.17401	0.16897	0.16428	0.16005	0.15658	0.15318
4.9	5.40	0.33614	0.32188	0.30641	0.29480	0.28225	0.27265	0.26232	0.24575	0.23172	0.21984	0.20968	0.20084	0.19315	0.18635	0.18041	0.17519	0.17034	0.16597	0.16238	0.15886

Recommended Head Loss Design Range

Sizing in this region will lead to excessive head loss conditions.

Appendix D

Uponor PEX-a Hydronic Friction Loss Tables

1" Uponor PEX-a — 100% Water — Feet of Head per 100 Feet of Tubing

Velocity (ft./sec.)	GPM	40°F 4°C	45°F 7°C	50°F 10°C	55°F 13°C	60°F 16°C	65°F 18°C	70°F 21°C	80°F 27°C	90°F 32°C	100°F 38°C	110°F 43°C	120°F 49°C	130°F 54°C	140°F 60°C	150°F 66°C	160°F 71°C	170°F 77°C	180°F 82°C	190°F 88°C	200°F 93°C
1.5	2.73	1.81	1.72	1.62	1.58	1.55	1.52	1.49	1.45	1.40	1.36	1.33	1.30	1.27	1.25	1.22	1.20	1.18	1.16	1.15	1.13
1.6	2.91	2.02	1.92	1.81	1.77	1.73	1.70	1.67	1.62	1.57	1.53	1.49	1.45	1.42	1.40	1.37	1.35	1.32	1.30	1.28	1.27
1.7	3.09	2.24	2.13	2.01	1.97	1.93	1.89	1.86	1.80	1.75	1.70	1.66	1.62	1.58	1.55	1.52	1.50	1.47	1.45	1.43	1.41
1.8	3.27	2.47	2.35	2.21	2.17	2.13	2.09	2.05	1.99	1.93	1.88	1.83	1.79	1.75	1.72	1.68	1.66	1.63	1.60	1.58	1.56
1.9	3.46	2.71	2.58	2.43	2.39	2.34	2.30	2.26	2.18	2.12	2.06	2.01	1.97	1.93	1.89	1.85	1.82	1.79	1.77	1.74	1.72
2.0	3.64	2.96	2.82	2.66	2.61	2.56	2.51	2.47	2.39	2.32	2.26	2.20	2.15	2.11	2.07	2.03	2.00	1.96	1.93	1.91	1.88
2.1	3.82	3.22	3.07	2.89	2.84	2.78	2.74	2.69	2.60	2.53	2.46	2.40	2.35	2.30	2.25	2.21	2.18	2.14	2.11	2.08	2.05
2.2	4.00	3.49	3.32	3.14	3.08	3.02	2.97	2.91	2.82	2.74	2.67	2.61	2.55	2.49	2.45	2.40	2.36	2.32	2.29	2.26	2.23
2.3	4.18	3.77	3.59	3.39	3.33	3.26	3.21	3.15	3.05	2.96	2.89	2.82	2.75	2.70	2.65	2.60	2.56	2.51	2.48	2.44	2.41
2.4	4.37	4.06	3.87	3.65	3.58	3.51	3.45	3.39	3.29	3.19	3.11	3.04	2.97	2.91	2.85	2.80	2.76	2.71	2.67	2.64	2.60
2.5	4.55	4.35	4.15	3.92	3.85	3.77	3.71	3.64	3.53	3.43	3.34	3.26	3.19	3.13	3.07	3.01	2.96	2.92	2.87	2.83	2.80
2.6	4.73	4.66	4.44	4.20	4.12	4.04	3.97	3.90	3.78	3.68	3.58	3.50	3.42	3.35	3.29	3.23	3.18	3.13	3.08	3.04	3.00
2.7	4.91	4.97	4.74	4.48	4.40	4.32	4.24	4.17	4.04	3.93	3.83	3.74	3.66	3.58	3.52	3.45	3.40	3.34	3.30	3.25	3.21
2.8	5.09	5.30	5.05	4.78	4.69	4.60	4.52	4.44	4.31	4.19	4.08	3.99	3.90	3.82	3.75	3.68	3.62	3.57	3.52	3.47	3.42
2.9	5.28	5.63	5.37	5.08	4.99	4.89	4.81	4.73	4.58	4.46	4.34	4.24	4.15	4.07	3.99	3.92	3.86	3.80	3.74	3.69	3.65
3.0	5.46	5.97	5.70	5.39	5.29	5.19	5.11	5.02	4.87	4.73	4.61	4.50	4.41	4.32	4.24	4.16	4.10	4.03	3.98	3.92	3.87
3.1	5.64	6.32	6.03	5.71	5.61	5.50	5.41	5.31	5.15	5.01	4.89	4.77	4.67	4.58	4.49	4.41	4.34	4.28	4.22	4.16	4.11
3.2	5.82	6.68	6.38	6.03	5.93	5.81	5.72	5.62	5.45	5.30	5.17	5.05	4.94	4.84	4.75	4.67	4.60	4.53	4.46	4.40	4.35
3.3	6.00	7.05	6.73	6.37	6.25	6.13	6.04	5.93	5.75	5.60	5.46	5.33	5.22	5.11	5.02	4.93	4.86	4.78	4.71	4.65	4.59
3.4	6.19	7.42	7.09	6.71	6.59	6.46	6.36	6.25	6.07	5.90	5.75	5.62	5.50	5.39	5.29	5.20	5.12	5.04	4.97	4.91	4.85
3.5	6.37	7.81	7.46	7.06	6.93	6.80	6.69	6.58	6.38	6.21	6.06	5.92	5.79	5.68	5.58	5.48	5.39	5.31	5.24	5.17	5.10
3.6	6.55	8.20	7.83	7.42	7.29	7.15	7.03	6.91	6.71	6.53	6.37	6.22	6.09	5.97	5.86	5.76	5.67	5.58	5.51	5.43	5.37
3.7	6.73	8.60	8.22	7.78	7.65	7.50	7.38	7.26	7.04	6.85	6.68	6.53	6.39	6.27	6.16	6.05	5.95	5.86	5.78	5.71	5.64
3.8	6.91	9.01	8.61	8.16	8.01	7.86	7.74	7.61	7.38	7.18	7.01	6.85	6.70	6.57	6.45	6.34	6.25	6.15	6.07	5.99	5.91
3.9	7.09	9.43	9.01	8.54	8.39	8.23	8.10	7.96	7.73	7.52	7.34	7.17	7.02	6.88	6.76	6.65	6.54	6.44	6.35	6.27	6.19
4.0	7.28	9.85	9.42	8.93	8.77	8.60	8.47	8.33	8.08	7.87	7.67	7.50	7.34	7.20	7.07	6.95	6.84	6.74	6.65	6.56	6.48
4.1	7.46	10.29	9.84	9.32	9.16	8.99	8.85	8.70	8.44	8.22	8.02	7.84	7.67	7.53	7.39	7.27	7.15	7.05	6.95	6.86	6.78
4.2	7.64	10.73	10.26	9.72	9.55	9.38	9.23	9.08	8.81	8.58	8.37	8.18	8.01	7.86	7.72	7.59	7.47	7.36	7.26	7.16	7.08
4.3	7.82	11.18	10.69	10.14	9.96	9.77	9.62	9.46	9.19	8.94	8.72	8.53	8.35	8.19	8.05	7.91	7.79	7.67	7.57	7.47	7.38
4.4	8.00	11.64	11.13	10.55	10.37	10.18	10.02	9.85	9.57	9.31	9.09	8.89	8.70	8.54	8.38	8.24	8.12	8.00	7.89	7.79	7.69
4.5	8.19	12.11	11.58	10.98	10.79	10.59	10.42	10.25	9.96	9.69	9.46	9.25	9.06	8.88	8.73	8.58	8.45	8.32	8.21	8.11	8.01
4.6	8.37	12.58	12.03	11.41	11.22	11.01	10.84	10.66	10.35	10.08	9.83	9.62	9.42	9.24	9.08	8.93	8.79	8.66	8.54	8.43	8.33
4.7	8.55	13.06	12.50	11.85	11.65	11.43	11.26	11.07	10.75	10.47	10.22	9.99	9.79	9.60	9.43	9.28	9.13	9.00	8.88	8.76	8.66
4.8	8.73	13.55	12.97	12.30	12.09	11.87	11.68	11.49	11.16	10.87	10.61	10.37	10.16	9.97	9.79	9.63	9.48	9.34	9.22	9.10	8.99

Continued on next page

Recommended Head Loss Design Range

5.5 ft./sec. is an industry standard for velocity limit in hydronic distribution systems.

Velocities in excess of 8 ft./sec. may cause erosion to metal components in the system.

Appendix D

Uponor PEX-a Hydronic Friction Loss Tables

1" Uponor PEX-a — 100% Water — Feet of Head per 100 Feet of Tubing

Velocity (ft./sec.)	GPM	40°F 4°C	45°F 7°C	50°F 10°C	55°F 13°C	60°F 16°C	65°F 18°C	70°F 21°C	80°F 27°C	90°F 32°C	100°F 38°C	110°F 43°C	120°F 49°C	130°F 54°C	140°F 60°C	150°F 66°C	160°F 71°C	170°F 77°C	180°F 82°C	190°F 88°C	200°F 93°C
4.9	8.91	14.05	13.45	12.76	12.54	12.31	12.12	11.92	11.58	11.28	11.00	10.76	10.54	10.34	10.16	9.99	9.84	9.70	9.57	9.45	9.33
5.0	9.10	14.56	13.93	13.22	12.99	12.75	12.56	12.35	12.00	11.69	11.41	11.16	10.93	10.72	10.54	10.36	10.20	10.05	9.92	9.80	9.68
5.1	9.28	15.07	14.42	13.69	13.45	13.21	13.01	12.79	12.43	12.11	11.82	11.56	11.32	11.11	10.92	10.74	10.57	10.42	10.28	10.15	10.03
5.2	9.46	15.59	14.93	14.17	13.92	13.67	13.46	13.24	12.86	12.53	12.23	11.96	11.72	11.50	11.30	11.12	10.95	10.79	10.64	10.51	10.39
5.3	9.64	16.12	15.43	14.65	14.40	14.14	13.92	13.70	13.31	12.96	12.65	12.38	12.13	11.90	11.69	11.50	11.33	11.16	11.01	10.88	10.75
5.4	9.82	16.66	15.95	15.14	14.88	14.61	14.39	14.16	13.76	13.40	13.08	12.80	12.54	12.30	12.09	11.89	11.71	11.54	11.39	11.25	11.12
5.5	10.01	17.21	16.47	15.64	15.37	15.10	14.87	14.63	14.21	13.85	13.52	13.22	12.96	12.71	12.49	12.29	12.11	11.93	11.77	11.63	11.49
5.6	10.19	17.76	17.00	16.14	15.87	15.59	15.35	15.10	14.67	14.30	13.96	13.66	13.38	13.13	12.90	12.69	12.50	12.32	12.16	12.01	11.87
5.7	10.37	18.32	17.54	16.66	16.38	16.08	15.84	15.58	15.14	14.75	14.41	14.09	13.81	13.55	13.32	13.10	12.91	12.72	12.55	12.40	12.25
5.8	10.55	18.89	18.09	17.18	16.89	16.58	16.33	16.07	15.62	15.22	14.86	14.54	14.25	13.98	13.74	13.52	13.32	13.13	12.95	12.79	12.64
5.9	10.73	19.46	18.64	17.70	17.41	17.09	16.84	16.57	16.10	15.69	15.32	14.99	14.69	14.42	14.17	13.94	13.73	13.54	13.36	13.19	13.04
6.0	10.92	20.05	19.20	18.24	17.93	17.61	17.35	17.07	16.59	16.17	15.79	15.45	15.14	14.86	14.60	14.37	14.15	13.95	13.77	13.60	13.44
6.1	11.10	20.64	19.77	18.78	18.46	18.13	17.86	17.58	17.08	16.65	16.26	15.91	15.59	15.30	15.04	14.80	14.58	14.37	14.18	14.01	13.85
6.2	11.28	21.24	20.34	19.33	19.00	18.66	18.38	18.09	17.58	17.14	16.74	16.38	16.05	15.76	15.49	15.24	15.01	14.80	14.61	14.43	14.26
6.3	11.46	21.84	20.93	19.88	19.55	19.20	18.91	18.61	18.09	17.63	17.22	16.85	16.52	16.21	15.94	15.68	15.45	15.23	15.03	14.85	14.68
6.4	11.64	22.46	21.51	20.44	20.10	19.74	19.45	19.14	18.61	18.14	17.71	17.34	16.99	16.68	16.40	16.13	15.89	15.67	15.47	15.28	15.10
6.5	11.82	23.08	22.11	21.01	20.66	20.30	19.99	19.67	19.13	18.64	18.21	17.82	17.47	17.15	16.86	16.59	16.34	16.11	15.90	15.71	15.53
6.6	12.01	23.71	22.71	21.59	21.23	20.85	20.54	20.22	19.66	19.16	18.71	18.32	17.95	17.63	17.33	17.05	16.80	16.56	16.35	16.15	15.96
6.7	12.19	24.34	23.33	22.17	21.80	21.42	21.10	20.76	20.19	19.68	19.22	18.82	18.44	18.11	17.80	17.52	17.26	17.02	16.80	16.59	16.40
6.8	12.37	24.98	23.94	22.76	22.38	21.99	21.66	21.32	20.73	20.21	19.74	19.32	18.94	18.59	18.28	17.99	17.73	17.48	17.25	17.04	16.84
6.9	12.55	25.63	24.57	23.36	22.97	22.56	22.23	21.88	21.27	20.74	20.26	19.83	19.44	19.09	18.77	18.47	18.20	17.94	17.71	17.50	17.29
7.0	12.73	26.29	25.20	23.96	23.56	23.15	22.81	22.45	21.83	21.28	20.79	20.35	19.95	19.59	19.26	18.95	18.68	18.41	18.18	17.96	17.75
7.1	12.92	26.96	25.84	24.57	24.16	23.74	23.39	23.02	22.39	21.83	21.32	20.87	20.46	20.09	19.76	19.44	19.16	18.89	18.65	18.42	18.21
7.2	13.10	27.63	26.49	25.18	24.77	24.34	23.98	23.60	22.95	22.38	21.86	21.40	20.98	20.60	20.26	19.94	19.65	19.37	19.12	18.89	18.68
7.3	13.28	28.31	27.14	25.81	25.38	24.94	24.57	24.19	23.52	22.94	22.41	21.94	21.51	21.12	20.77	20.44	20.14	19.86	19.61	19.37	19.15
7.4	13.46	29.00	27.80	26.44	26.01	25.55	25.17	24.78	24.10	23.50	22.96	22.48	22.04	21.64	21.28	20.95	20.64	20.35	20.09	19.85	19.63
7.5	13.64	29.69	28.47	27.08	26.63	26.17	25.78	25.38	24.68	24.07	23.52	23.03	22.58	22.17	21.80	21.46	21.15	20.85	20.59	20.34	20.11
7.6	13.83	30.39	29.14	27.72	27.27	26.79	26.40	25.98	25.28	24.65	24.08	23.58	23.12	22.70	22.33	21.98	21.66	21.36	21.08	20.83	20.60
7.7	14.01	31.10	29.82	28.37	27.91	27.42	27.02	26.60	25.87	25.23	24.65	24.14	23.67	23.24	22.86	22.50	22.17	21.87	21.59	21.33	21.09
7.8	14.19	31.82	30.51	29.03	28.55	28.06	27.65	27.22	26.47	25.82	25.23	24.70	24.22	23.79	23.39	23.03	22.70	22.38	22.10	21.83	21.59
7.9	14.37	32.54	31.21	29.69	29.21	28.70	28.28	27.84	27.08	26.41	25.81	25.27	24.78	24.34	23.94	23.56	23.22	22.90	22.61	22.34	22.09
8.0	14.55	33.27	31.91	30.36	29.87	29.35	28.92	28.47	27.70	27.01	26.40	25.85	25.35	24.90	24.49	24.10	23.76	23.43	23.13	22.86	22.60

Recommended Head Loss Design Range

5.5 ft./sec. is an industry standard for velocity limit in hydronic distribution systems.

Velocities in excess of 8 ft./sec. may cause erosion to metal components in the system.

Appendix D

Uponor PEX-a Hydronic Friction Loss Tables

1" Uponor PEX-a — 30% Propylene Glycol — Feet of Head per 100 Feet of Tubing

Velocity (ft./sec.)	GPM	40°F 4°C	45°F 7°C	50°F 10°C	55°F 13°C	60°F 16°C	65°F 18°C	70°F 21°C	80°F 27°C	90°F 32°C	100°F 38°C	110°F 43°C	120°F 49°C	130°F 54°C	140°F 60°C	150°F 66°C	160°F 71°C	170°F 77°C	180°F 82°C	190°F 88°C	200°F 93°C
1.5	2.73	2.49	2.40	2.30	2.23	2.15	2.09	2.02	1.91	1.82	1.74	1.67	1.61	1.55	1.50	1.47	1.43	1.39	1.36	1.33	1.31
1.6	2.91	2.77	2.67	2.57	2.49	2.40	2.33	2.25	2.13	2.03	1.94	1.86	1.80	1.74	1.68	1.64	1.60	1.56	1.53	1.49	1.47
1.7	3.09	3.07	2.96	2.84	2.75	2.66	2.58	2.50	2.37	2.25	2.15	2.07	1.99	1.93	1.87	1.82	1.78	1.73	1.70	1.66	1.64
1.8	3.27	3.38	3.26	3.13	3.03	2.93	2.85	2.76	2.61	2.48	2.38	2.28	2.20	2.13	2.07	2.01	1.96	1.91	1.88	1.84	1.81
1.9	3.46	3.70	3.57	3.43	3.33	3.21	3.12	3.02	2.86	2.73	2.61	2.51	2.42	2.34	2.27	2.21	2.16	2.10	2.06	2.02	1.99
2.0	3.64	4.03	3.89	3.74	3.63	3.51	3.41	3.30	3.13	2.98	2.85	2.74	2.64	2.56	2.48	2.42	2.36	2.30	2.26	2.21	2.18
2.1	3.82	4.38	4.23	4.07	3.94	3.81	3.70	3.59	3.40	3.24	3.10	2.98	2.88	2.79	2.70	2.63	2.57	2.51	2.46	2.41	2.37
2.2	4.00	4.74	4.57	4.40	4.27	4.12	4.01	3.88	3.68	3.51	3.36	3.23	3.12	3.02	2.93	2.86	2.79	2.72	2.67	2.61	2.57
2.3	4.18	5.11	4.93	4.75	4.60	4.45	4.32	4.19	3.98	3.79	3.63	3.49	3.37	3.26	3.17	3.09	3.01	2.94	2.88	2.83	2.78
2.4	4.37	5.49	5.30	5.10	4.95	4.78	4.65	4.51	4.28	4.08	3.91	3.76	3.63	3.52	3.41	3.33	3.25	3.17	3.11	3.05	3.00
2.5	4.55	5.88	5.68	5.47	5.31	5.13	4.99	4.84	4.59	4.38	4.20	4.04	3.90	3.78	3.67	3.58	3.49	3.41	3.34	3.27	3.22
2.6	4.73	6.28	6.07	5.85	5.67	5.49	5.34	5.17	4.91	4.69	4.49	4.32	4.18	4.04	3.93	3.83	3.74	3.65	3.58	3.51	3.46
2.7	4.91	6.70	6.48	6.24	6.05	5.85	5.69	5.52	5.24	5.00	4.80	4.61	4.46	4.32	4.19	4.09	3.99	3.90	3.83	3.75	3.69
2.8	5.09	7.13	6.89	6.64	6.44	6.23	6.06	5.88	5.58	5.33	5.11	4.92	4.75	4.60	4.47	4.36	4.26	4.16	4.08	4.00	3.94
2.9	5.28	7.56	7.31	7.05	6.84	6.62	6.44	6.24	5.93	5.66	5.43	5.23	5.05	4.90	4.75	4.64	4.53	4.43	4.34	4.25	4.19
3.0	5.46	8.01	7.75	7.47	7.25	7.01	6.82	6.62	6.29	6.01	5.76	5.55	5.36	5.20	5.05	4.93	4.81	4.70	4.61	4.52	4.45
3.1	5.64	8.47	8.19	7.90	7.67	7.42	7.22	7.01	6.66	6.36	6.10	5.87	5.68	5.50	5.35	5.22	5.09	4.98	4.88	4.79	4.72
3.2	5.82	8.94	8.65	8.34	8.10	7.84	7.63	7.40	7.04	6.72	6.45	6.21	6.00	5.82	5.65	5.52	5.39	5.27	5.16	5.06	4.99
3.3	6.00	9.42	9.12	8.79	8.53	8.26	8.04	7.80	7.42	7.09	6.80	6.55	6.34	6.14	5.97	5.83	5.69	5.56	5.45	5.35	5.27
3.4	6.19	9.92	9.60	9.25	8.98	8.70	8.47	8.22	7.81	7.47	7.17	6.90	6.68	6.47	6.29	6.14	5.99	5.86	5.75	5.64	5.56
3.5	6.37	10.42	10.08	9.72	9.44	9.14	8.90	8.64	8.22	7.85	7.54	7.26	7.02	6.81	6.62	6.46	6.31	6.17	6.05	5.94	5.85
3.6	6.55	10.93	10.58	10.20	9.91	9.60	9.34	9.07	8.63	8.25	7.92	7.63	7.38	7.16	6.95	6.79	6.63	6.48	6.36	6.24	6.15
3.7	6.73	11.46	11.09	10.70	10.39	10.06	9.80	9.51	9.05	8.65	8.31	8.00	7.74	7.51	7.30	7.13	6.96	6.81	6.68	6.55	6.46
3.8	6.91	11.99	11.61	11.20	10.88	10.54	10.26	9.96	9.48	9.06	8.70	8.38	8.11	7.87	7.65	7.47	7.30	7.13	7.00	6.87	6.77
3.9	7.09	12.53	12.14	11.71	11.38	11.02	10.73	10.42	9.92	9.48	9.11	8.78	8.49	8.24	8.01	7.82	7.64	7.47	7.33	7.19	7.09
4.0	7.28	13.09	12.67	12.23	11.88	11.51	11.21	10.89	10.36	9.91	9.52	9.17	8.88	8.61	8.37	8.18	7.99	7.81	7.67	7.52	7.41
4.1	7.46	13.65	13.22	12.76	12.40	12.01	11.70	11.36	10.82	10.35	9.94	9.58	9.27	9.00	8.75	8.54	8.35	8.16	8.01	7.86	7.75
4.2	7.64	14.23	13.78	13.30	12.93	12.52	12.20	11.85	11.28	10.79	10.37	9.99	9.67	9.39	9.13	8.92	8.71	8.52	8.36	8.20	8.09
4.3	7.82	14.81	14.35	13.85	13.46	13.04	12.71	12.34	11.75	11.24	10.80	10.41	10.08	9.79	9.51	9.29	9.08	8.88	8.72	8.55	8.43
4.4	8.00	15.41	14.93	14.41	14.01	13.57	13.22	12.85	12.24	11.71	11.25	10.84	10.50	10.19	9.91	9.68	9.46	9.25	9.08	8.91	8.79
4.5	8.19	16.02	15.52	14.98	14.56	14.11	13.75	13.36	12.72	12.17	11.70	11.28	10.92	10.60	10.31	10.07	9.84	9.63	9.45	9.27	9.14
4.6	8.37	16.63	16.11	15.56	15.12	14.66	14.28	13.88	13.22	12.65	12.16	11.72	11.35	11.02	10.72	10.47	10.23	10.01	9.83	9.64	9.51
4.7	8.55	17.26	16.72	16.15	15.70	15.21	14.82	14.41	13.73	13.14	12.63	12.18	11.79	11.45	11.13	10.88	10.63	10.40	10.21	10.02	9.88
4.8	8.73	17.89	17.34	16.74	16.28	15.78	15.38	14.94	14.24	13.63	13.10	12.64	12.24	11.88	11.55	11.29	11.04	10.80	10.60	10.40	10.26

Continued on next page

Recommended Head Loss Design Range

5.5 ft./sec. is an industry standard for velocity limit in hydronic distribution systems.

Velocities in excess of 8 ft./sec. may cause erosion to metal components in the system.

Appendix D

Uponor PEX-a Hydronic Friction Loss Tables

1" Uponor PEX-a — 30% Propylene Glycol — Feet of Head per 100 Feet of Tubing

Velocity (ft./sec.)	GPM	40°F 4°C	45°F 7°C	50°F 10°C	55°F 13°C	60°F 16°C	65°F 18°C	70°F 21°C	80°F 27°C	90°F 32°C	100°F 38°C	110°F 43°C	120°F 49°C	130°F 54°C	140°F 60°C	150°F 66°C	160°F 71°C	170°F 77°C	180°F 82°C	190°F 88°C	200°F 93°C
4.9	8.91	18.54	17.97	17.35	16.87	16.35	15.94	15.49	14.76	14.13	13.58	13.10	12.69	12.32	11.98	11.71	11.45	11.20	11.00	10.79	10.64
5.0	9.10	19.19	18.60	17.97	17.47	16.94	16.51	16.04	15.29	14.64	14.07	13.58	13.15	12.77	12.42	12.14	11.86	11.61	11.40	11.19	11.03
5.1	9.28	19.86	19.25	18.59	18.08	17.53	17.08	16.61	15.83	15.16	14.57	14.06	13.62	13.22	12.86	12.57	12.29	12.03	11.81	11.59	11.43
5.2	9.46	20.53	19.90	19.23	18.70	18.13	17.67	17.18	16.38	15.68	15.08	14.55	14.09	13.69	13.31	13.01	12.72	12.45	12.22	12.00	11.83
5.3	9.64	21.22	20.57	19.87	19.32	18.74	18.27	17.76	16.93	16.21	15.59	15.04	14.58	14.16	13.77	13.46	13.16	12.88	12.64	12.41	12.24
5.4	9.82	21.91	21.24	20.52	19.96	19.36	18.87	18.35	17.49	16.75	16.11	15.55	15.07	14.63	14.23	13.92	13.60	13.31	13.07	12.83	12.66
5.5	10.01	22.61	21.93	21.18	20.61	19.98	19.48	18.94	18.06	17.30	16.64	16.06	15.56	15.11	14.70	14.38	14.05	13.76	13.51	13.26	13.08
5.6	10.19	23.33	22.62	21.86	21.26	20.62	20.10	19.55	18.64	17.86	17.18	16.58	16.06	15.60	15.18	14.84	14.51	14.20	13.95	13.69	13.51
5.7	10.37	24.05	23.32	22.54	21.92	21.26	20.73	20.16	19.23	18.42	17.72	17.10	16.57	16.10	15.67	15.32	14.97	14.66	14.39	14.13	13.94
5.8	10.55	24.78	24.03	23.22	22.59	21.92	21.37	20.78	19.82	18.99	18.27	17.63	17.09	16.60	16.16	15.80	15.45	15.12	14.85	14.58	14.38
5.9	10.73	25.52	24.75	23.92	23.27	22.58	22.01	21.41	20.43	19.57	18.83	18.17	17.62	17.11	16.65	16.28	15.92	15.59	15.31	15.03	14.83
6.0	10.92	26.27	25.48	24.63	23.96	23.25	22.67	22.05	21.04	20.16	19.39	18.72	18.15	17.63	17.16	16.78	16.41	16.06	15.77	15.49	15.28
6.1	11.10	27.04	26.22	25.35	24.66	23.93	23.33	22.69	21.65	20.75	19.97	19.28	18.69	18.15	17.67	17.28	16.90	16.54	16.25	15.95	15.74
6.2	11.28	27.80	26.97	26.07	25.37	24.61	24.00	23.35	22.28	21.35	20.55	19.84	19.23	18.69	18.19	17.79	17.39	17.03	16.72	16.42	16.20
6.3	11.46	28.58	27.73	26.80	26.08	25.31	24.68	24.01	22.91	21.96	21.13	20.41	19.78	19.22	18.71	18.30	17.89	17.52	17.21	16.90	16.67
6.4	11.64	29.37	28.49	27.55	26.81	26.01	25.37	24.68	23.55	22.58	21.73	20.98	20.34	19.77	19.24	18.82	18.40	18.02	17.70	17.38	17.15
6.5	11.82	30.17	29.27	28.30	27.54	26.73	26.07	25.36	24.20	23.20	22.33	21.56	20.91	20.32	19.78	19.35	18.92	18.52	18.20	17.87	17.63
6.6	12.01	30.98	30.05	29.06	28.28	27.45	26.77	26.04	24.86	23.83	22.94	22.15	21.48	20.88	20.32	19.88	19.44	19.04	18.70	18.37	18.12
6.7	12.19	31.79	30.85	29.83	29.03	28.18	27.48	26.74	25.53	24.47	23.56	22.75	22.06	21.44	20.87	20.42	19.97	19.55	19.21	18.87	18.61
6.8	12.37	32.62	31.65	30.60	29.79	28.91	28.20	27.44	26.20	25.12	24.18	23.35	22.65	22.01	21.43	20.96	20.50	20.08	19.72	19.37	19.11
6.9	12.55	33.45	32.46	31.39	30.56	29.66	28.93	28.15	26.88	25.77	24.81	23.97	23.24	22.59	21.99	21.51	21.04	20.61	20.25	19.89	19.62
7.0	12.73	34.29	33.28	32.19	31.33	30.41	29.67	28.87	27.57	26.43	25.45	24.58	23.84	23.17	22.56	22.07	21.59	21.14	20.77	20.40	20.13
7.1	12.92	35.15	34.11	32.99	32.11	31.17	30.41	29.60	28.26	27.10	26.10	25.21	24.45	23.77	23.14	22.64	22.14	21.69	21.31	20.93	20.65
7.2	13.10	36.01	34.95	33.80	32.91	31.94	31.16	30.33	28.96	27.78	26.75	25.84	25.06	24.36	23.72	23.21	22.70	22.24	21.85	21.46	21.17
7.3	13.28	36.88	35.79	34.62	33.71	32.72	31.93	31.07	29.67	28.46	27.41	26.48	25.68	24.97	24.31	23.79	23.27	22.79	22.39	22.00	21.70
7.4	13.46	37.76	36.65	35.45	34.51	33.51	32.69	31.82	30.39	29.15	28.07	27.12	26.31	25.58	24.91	24.37	23.84	23.35	22.94	22.54	22.24
7.5	13.64	38.65	37.51	36.29	35.33	34.30	33.47	32.58	31.12	29.85	28.75	27.78	26.94	26.20	25.51	24.96	24.42	23.92	23.50	23.09	22.78
7.6	13.83	39.54	38.39	37.13	36.16	35.11	34.26	33.34	31.85	30.55	29.43	28.43	27.59	26.82	26.12	25.56	25.00	24.49	24.07	23.64	23.33
7.7	14.01	40.45	39.27	37.99	36.99	35.92	35.05	34.12	32.59	31.27	30.12	29.10	28.23	27.45	26.74	26.16	25.59	25.07	24.63	24.20	23.88
7.8	14.19	41.37	40.16	38.85	37.83	36.74	35.85	34.90	33.34	31.99	30.81	29.77	28.89	28.09	27.36	26.77	26.19	25.66	25.21	24.77	24.44
7.9	14.37	42.29	41.06	39.72	38.68	37.57	36.66	35.69	34.09	32.71	31.51	30.45	29.55	28.73	27.98	27.38	26.79	26.25	25.79	25.34	25.01
8.0	14.55	43.22	41.96	40.60	39.54	38.40	37.47	36.48	34.86	33.45	32.22	31.14	30.22	29.38	28.62	28.01	27.40	26.85	26.38	25.92	25.58

Velocities in excess of 8 ft./sec. may cause erosion to metal components in the system.

5.5 ft./sec. is an industry standard for velocity limit in hydronic distribution systems.

Recommended Head Loss Design Range

Appendix D

Uponor PEX-a Hydronic Friction Loss Tables

1" Uponor PEX-a —40% Propylene Glycol — Feet of Head per 100 Feet of Tubing

Velocity (ft./sec.)	GPM	40°F 4°C	45°F 7°C	50°F 10°C	55°F 13°C	60°F 16°C	65°F 18°C	70°F 21°C	80°F 27°C	90°F 32°C	100°F 38°C	110°F 43°C	120°F 49°C	130°F 54°C	140°F 60°C	150°F 66°C	160°F 71°C	170°F 77°C	180°F 82°C	190°F 88°C	200°F 93°C
1.5	2.73	2.95	2.82	2.68	2.57	2.46	2.37	2.28	2.13	2.01	1.90	1.81	1.74	1.67	1.61	1.56	1.52	1.47	1.44	1.41	1.38
1.6	2.91	3.28	3.14	2.98	2.86	2.74	2.64	2.54	2.38	2.24	2.13	2.03	1.94	1.87	1.80	1.75	1.70	1.65	1.61	1.57	1.55
1.7	3.09	3.63	3.47	3.30	3.17	3.03	2.93	2.82	2.63	2.48	2.36	2.25	2.15	2.07	2.00	1.94	1.89	1.83	1.79	1.75	1.72
1.8	3.27	3.99	3.82	3.63	3.49	3.34	3.22	3.10	2.90	2.74	2.60	2.48	2.38	2.29	2.21	2.14	2.08	2.03	1.98	1.93	1.90
1.9	3.46	4.37	4.18	3.97	3.82	3.66	3.53	3.40	3.18	3.00	2.85	2.72	2.61	2.51	2.43	2.35	2.29	2.23	2.18	2.13	2.09
2.0	3.64	4.75	4.55	4.33	4.16	3.99	3.85	3.71	3.47	3.28	3.12	2.98	2.85	2.75	2.65	2.57	2.50	2.43	2.38	2.33	2.28
2.1	3.82	5.16	4.93	4.70	4.52	4.33	4.18	4.03	3.78	3.56	3.39	3.24	3.10	2.99	2.89	2.80	2.73	2.65	2.60	2.53	2.49
2.2	4.00	5.57	5.33	5.08	4.89	4.68	4.53	4.36	4.09	3.86	3.67	3.51	3.36	3.24	3.13	3.04	2.96	2.88	2.82	2.75	2.70
2.3	4.18	6.00	5.75	5.47	5.27	5.05	4.88	4.70	4.41	4.17	3.96	3.79	3.63	3.50	3.38	3.28	3.20	3.11	3.05	2.97	2.92
2.4	4.37	6.44	6.17	5.88	5.66	5.42	5.24	5.05	4.74	4.48	4.26	4.08	3.91	3.77	3.64	3.53	3.44	3.35	3.28	3.20	3.15
2.5	4.55	6.90	6.61	6.30	6.06	5.81	5.62	5.42	5.09	4.81	4.57	4.37	4.20	4.04	3.91	3.80	3.70	3.60	3.52	3.44	3.38
2.6	4.73	7.36	7.06	6.73	6.48	6.21	6.01	5.79	5.44	5.14	4.89	4.68	4.49	4.33	4.19	4.06	3.96	3.85	3.78	3.69	3.62
2.7	4.91	7.85	7.52	7.17	6.91	6.62	6.41	6.18	5.80	5.49	5.22	5.00	4.80	4.62	4.47	4.34	4.23	4.12	4.04	3.94	3.87
2.8	5.09	8.34	7.99	7.62	7.34	7.05	6.82	6.57	6.18	5.84	5.56	5.32	5.11	4.93	4.76	4.63	4.51	4.39	4.30	4.20	4.13
2.9	5.28	8.84	8.48	8.09	7.79	7.48	7.24	6.98	6.56	6.21	5.91	5.66	5.43	5.24	5.07	4.92	4.79	4.67	4.58	4.47	4.39
3.0	5.46	9.36	8.98	8.57	8.26	7.92	7.67	7.39	6.95	6.58	6.27	6.00	5.76	5.56	5.38	5.22	5.09	4.96	4.86	4.75	4.66
3.1	5.64	9.89	9.49	9.05	8.73	8.38	8.11	7.82	7.36	6.96	6.64	6.35	6.10	5.89	5.69	5.53	5.39	5.25	5.15	5.03	4.94
3.2	5.82	10.44	10.01	9.55	9.21	8.84	8.56	8.26	7.77	7.36	7.01	6.71	6.45	6.22	6.02	5.85	5.70	5.55	5.44	5.32	5.23
3.3	6.00	10.99	10.55	10.07	9.71	9.32	9.02	8.71	8.19	7.76	7.39	7.08	6.80	6.56	6.35	6.17	6.02	5.86	5.74	5.61	5.52
3.4	6.19	11.56	11.09	10.59	10.21	9.81	9.50	9.16	8.62	8.17	7.79	7.46	7.17	6.92	6.69	6.50	6.34	6.18	6.06	5.92	5.82
3.5	6.37	12.14	11.65	11.12	10.73	10.31	9.98	9.63	9.07	8.59	8.19	7.84	7.54	7.28	7.04	6.84	6.67	6.50	6.37	6.23	6.12
3.6	6.55	12.73	12.22	11.67	11.26	10.81	10.47	10.11	9.52	9.02	8.60	8.24	7.92	7.64	7.40	7.19	7.01	6.83	6.70	6.55	6.44
3.7	6.73	13.33	12.80	12.22	11.80	11.33	10.98	10.59	9.98	9.46	9.02	8.64	8.31	8.02	7.76	7.55	7.36	7.17	7.03	6.87	6.76
3.8	6.91	13.95	13.39	12.79	12.34	11.86	11.49	11.09	10.45	9.90	9.45	9.05	8.70	8.40	8.13	7.91	7.71	7.52	7.37	7.20	7.08
3.9	7.09	14.57	14.00	13.37	12.90	12.40	12.01	11.60	10.93	10.36	9.88	9.47	9.11	8.79	8.51	8.28	8.07	7.87	7.72	7.54	7.42
4.0	7.28	15.21	14.61	13.96	13.47	12.95	12.55	12.11	11.42	10.83	10.33	9.90	9.52	9.19	8.90	8.65	8.44	8.23	8.07	7.89	7.76
4.1	7.46	15.86	15.24	14.56	14.05	13.51	13.09	12.64	11.91	11.30	10.78	10.34	9.94	9.60	9.30	9.04	8.82	8.59	8.43	8.24	8.11
4.2	7.64	16.52	15.87	15.17	14.65	14.08	13.64	13.18	12.42	11.78	11.24	10.78	10.37	10.01	9.70	9.43	9.20	8.97	8.80	8.60	8.46
4.3	7.82	17.19	16.52	15.79	15.25	14.66	14.21	13.72	12.94	12.27	11.71	11.23	10.80	10.44	10.11	9.83	9.59	9.35	9.17	8.97	8.82
4.4	8.00	17.87	17.18	16.42	15.86	15.25	14.78	14.28	13.46	12.77	12.19	11.69	11.25	10.87	10.53	10.24	9.99	9.74	9.55	9.34	9.19
4.5	8.19	18.57	17.85	17.07	16.48	15.85	15.36	14.84	14.00	13.28	12.68	12.16	11.70	11.30	10.95	10.65	10.39	10.13	9.94	9.72	9.56
4.6	8.37	19.28	18.53	17.72	17.11	16.46	15.96	15.41	14.54	13.80	13.18	12.64	12.16	11.75	11.38	11.07	10.80	10.53	10.33	10.11	9.94
4.7	8.55	19.99	19.22	18.38	17.75	17.08	16.56	16.00	15.09	14.33	13.68	13.12	12.63	12.20	11.82	11.50	11.22	10.94	10.74	10.50	10.33
4.8	8.73	20.72	19.92	19.06	18.41	17.71	17.17	16.59	15.65	14.86	14.19	13.61	13.10	12.66	12.27	11.94	11.65	11.36	11.14	10.90	10.72

Continued on next page

5.5 ft./sec. is an industry standard for velocity limit in hydronic distribution systems.

Velocities in excess of 8 ft./sec. may cause erosion to metal components in the system.

Appendix D

Uponor PEX-a Hydronic Friction Loss Tables

1" Uponor PEX-a —40% Propylene Glycol — Feet of Head per 100 Feet of Tubing

Velocity (ft./sec.)	GPM	40°F 4°C	45°F 7°C	50°F 10°C	55°F 13°C	60°F 16°C	65°F 18°C	70°F 21°C	80°F 27°C	90°F 32°C	100°F 38°C	110°F 43°C	120°F 49°C	130°F 54°C	140°F 60°C	150°F 66°C	160°F 71°C	170°F 77°C	180°F 82°C	190°F 88°C	200°F 93°C
4.9	8.91	21.46	20.64	19.74	19.07	18.35	17.79	17.19	16.22	15.40	14.71	14.11	13.58	13.13	12.72	12.38	12.08	11.78	11.56	11.31	11.12
5.0	9.10	22.21	21.36	20.43	19.74	18.99	18.42	17.80	16.80	15.95	15.24	14.62	14.07	13.61	13.18	12.83	12.52	12.21	11.98	11.72	11.53
5.1	9.28	22.97	22.09	21.14	20.42	19.65	19.06	18.42	17.39	16.51	15.78	15.14	14.57	14.09	13.65	13.28	12.97	12.65	12.41	12.14	11.94
5.2	9.46	23.74	22.84	21.85	21.12	20.32	19.71	19.05	17.99	17.08	16.32	15.66	15.08	14.58	14.13	13.75	13.42	13.09	12.84	12.57	12.36
5.3	9.64	24.53	23.59	22.58	21.82	21.00	20.37	19.69	18.59	17.66	16.87	16.19	15.59	15.08	14.61	14.22	13.88	13.54	13.29	13.00	12.79
5.4	9.82	25.32	24.36	23.31	22.53	21.69	21.04	20.34	19.20	18.24	17.44	16.73	16.11	15.58	15.10	14.70	14.35	14.00	13.73	13.44	13.22
5.5	10.01	26.12	25.14	24.06	23.25	22.38	21.71	20.99	19.83	18.84	18.00	17.28	16.64	16.09	15.60	15.18	14.82	14.46	14.19	13.88	13.66
5.6	10.19	26.94	25.92	24.81	23.99	23.09	22.40	21.66	20.46	19.44	18.58	17.84	17.18	16.61	16.10	15.67	15.30	14.93	14.65	14.34	14.11
5.7	10.37	27.76	26.72	25.58	24.73	23.81	23.10	22.33	21.10	20.05	19.17	18.40	17.72	17.14	16.62	16.17	15.79	15.40	15.12	14.80	14.56
5.8	10.55	28.60	27.53	26.35	25.48	24.53	23.80	23.02	21.75	20.67	19.76	18.97	18.27	17.67	17.13	16.68	16.28	15.89	15.59	15.26	15.02
5.9	10.73	29.45	28.34	27.14	26.24	25.26	24.52	23.71	22.40	21.29	20.36	19.55	18.83	18.21	17.66	17.19	16.78	16.38	16.07	15.73	15.48
6.0	10.92	30.31	29.17	27.93	27.01	26.01	25.24	24.41	23.07	21.93	20.97	20.13	19.39	18.76	18.19	17.71	17.29	16.87	16.56	16.21	15.95
6.1	11.10	31.17	30.01	28.74	27.79	26.76	25.97	25.12	23.74	22.57	21.58	20.73	19.97	19.32	18.73	18.24	17.81	17.38	17.06	16.69	16.43
6.2	11.28	32.05	30.86	29.55	28.58	27.52	26.71	25.84	24.42	23.22	22.21	21.33	20.55	19.88	19.28	18.77	18.33	17.89	17.56	17.19	16.91
6.3	11.46	32.94	31.71	30.38	29.38	28.30	27.46	26.57	25.11	23.88	22.84	21.94	21.13	20.45	19.83	19.31	18.86	18.40	18.06	17.68	17.40
6.4	11.64	33.84	32.58	31.21	30.19	29.08	28.22	27.30	25.81	24.55	23.48	22.55	21.73	21.02	20.39	19.86	19.39	18.92	18.58	18.19	17.90
6.5	11.82	34.75	33.46	32.06	31.01	29.87	28.99	28.05	26.52	25.22	24.12	23.17	22.33	21.61	20.96	20.41	19.93	19.45	19.10	18.70	18.40
6.6	12.01	35.67	34.35	32.91	31.83	30.67	29.77	28.80	27.23	25.90	24.78	23.81	22.94	22.20	21.53	20.97	20.48	19.99	19.62	19.21	18.91
6.7	12.19	36.60	35.25	33.77	32.67	31.47	30.55	29.56	27.96	26.59	25.44	24.44	23.56	22.80	22.11	21.54	21.03	20.53	20.16	19.73	19.42
6.8	12.37	37.54	36.15	34.65	33.52	32.29	31.35	30.33	28.69	27.29	26.11	25.09	24.18	23.40	22.70	22.11	21.60	21.08	20.70	20.26	19.95
6.9	12.55	38.49	37.07	35.53	34.37	33.12	32.15	31.11	29.43	28.00	26.79	25.74	24.81	24.01	23.30	22.69	22.16	21.63	21.24	20.80	20.47
7.0	12.73	39.45	38.00	36.42	35.24	33.95	32.97	31.90	30.18	28.71	27.48	26.40	25.45	24.63	23.90	23.28	22.74	22.20	21.79	21.34	21.01
7.1	12.92	40.42	38.94	37.32	36.11	34.80	33.79	32.70	30.94	29.44	28.17	27.07	26.09	25.26	24.51	23.87	23.32	22.76	22.35	21.89	21.54
7.2	13.10	41.40	39.89	38.23	36.99	35.65	34.62	33.51	31.70	30.17	28.87	27.75	26.75	25.89	25.12	24.47	23.91	23.34	22.92	22.44	22.09
7.3	13.28	42.39	40.84	39.15	37.89	36.51	35.46	34.32	32.47	30.90	29.58	28.43	27.41	26.53	25.74	25.08	24.50	23.92	23.49	23.00	22.64
7.4	13.46	43.39	41.81	40.08	38.79	37.39	36.31	35.14	33.25	31.65	30.29	29.12	28.07	27.18	26.37	25.69	25.10	24.51	24.06	23.56	23.20
7.5	13.64	44.40	42.79	41.02	39.70	38.27	37.16	35.97	34.04	32.40	31.02	29.82	28.75	27.83	27.01	26.31	25.71	25.10	24.65	24.14	23.76
7.6	13.83	45.43	43.77	41.97	40.62	39.15	38.03	36.81	34.84	33.16	31.75	30.52	29.43	28.49	27.65	26.94	26.32	25.70	25.24	24.71	24.33
7.7	14.01	46.46	44.77	42.93	41.55	40.05	38.90	37.66	35.65	33.93	32.49	31.23	30.12	29.16	28.30	27.57	26.94	26.30	25.83	25.30	24.91
7.8	14.19	47.50	45.77	43.89	42.49	40.96	39.78	38.52	36.46	34.71	33.23	31.95	30.81	29.83	28.96	28.21	27.56	26.92	26.43	25.89	25.49
7.9	14.37	48.55	46.79	44.87	43.43	41.87	40.67	39.38	37.28	35.50	33.99	32.68	31.51	30.51	29.62	28.86	28.20	27.53	27.04	26.48	26.08
8.0	14.55	49.61	47.81	45.86	44.39	42.80	41.57	40.25	38.11	36.29	34.75	33.41	32.22	31.20	30.29	29.51	28.84	28.16	27.66	27.09	26.67

5.5 ft./sec. is an industry standard for velocity limit in hydronic distribution systems.

Velocities in excess of 8 ft./sec. may cause erosion to metal components in the system.

Recommended Head Loss Design Range

Appendix D

Uponor PEX-a Hydronic Friction Loss Tables

1" Uponor PEX-a — 50% Propylene Glycol — Feet of Head per 100 Feet of Tubing

Velocity (ft./sec.)	GPM	40°F 4°C	45°F 7°C	50°F 10°C	55°F 13°C	60°F 16°C	65°F 18°C	70°F 21°C	80°F 27°C	90°F 32°C	100°F 38°C	110°F 43°C	120°F 49°C	130°F 54°C	140°F 60°C	150°F 66°C	160°F 71°C	170°F 77°C	180°F 82°C	190°F 88°C	200°F 93°C
1.5	2.73	2.95	2.82	2.68	2.57	2.46	2.37	2.28	2.13	2.01	1.90	1.81	1.74	1.67	1.61	1.56	1.52	1.47	1.44	1.41	1.38
1.6	2.91	3.28	3.14	2.98	2.86	2.74	2.64	2.54	2.38	2.24	2.13	2.03	1.94	1.87	1.80	1.75	1.70	1.65	1.61	1.57	1.55
1.7	3.09	3.63	3.47	3.30	3.17	3.03	2.93	2.82	2.63	2.48	2.36	2.25	2.15	2.07	2.00	1.94	1.89	1.83	1.79	1.75	1.72
1.8	3.27	3.99	3.82	3.63	3.49	3.34	3.22	3.10	2.90	2.74	2.60	2.48	2.38	2.29	2.21	2.14	2.08	2.03	1.98	1.93	1.90
1.9	3.46	4.37	4.18	3.97	3.82	3.66	3.53	3.40	3.18	3.00	2.85	2.72	2.61	2.51	2.43	2.35	2.29	2.23	2.18	2.13	2.09
2.0	3.64	4.75	4.55	4.33	4.16	3.99	3.85	3.71	3.47	3.28	3.12	2.98	2.85	2.75	2.65	2.57	2.50	2.43	2.38	2.33	2.28
2.1	3.82	5.16	4.93	4.70	4.52	4.33	4.18	4.03	3.78	3.56	3.39	3.24	3.10	2.99	2.89	2.80	2.73	2.65	2.60	2.53	2.49
2.2	4.00	5.57	5.33	5.08	4.89	4.68	4.53	4.36	4.09	3.86	3.67	3.51	3.36	3.24	3.13	3.04	2.96	2.88	2.82	2.75	2.70
2.3	4.18	6.00	5.75	5.47	5.27	5.05	4.88	4.70	4.41	4.17	3.96	3.79	3.63	3.50	3.38	3.28	3.20	3.11	3.05	2.97	2.92
2.4	4.37	6.44	6.17	5.88	5.66	5.42	5.24	5.05	4.74	4.48	4.26	4.08	3.91	3.77	3.64	3.53	3.44	3.35	3.28	3.20	3.15
2.5	4.55	6.90	6.61	6.30	6.06	5.81	5.62	5.42	5.09	4.81	4.57	4.37	4.20	4.04	3.91	3.80	3.70	3.60	3.52	3.44	3.38
2.6	4.73	7.36	7.06	6.73	6.48	6.21	6.01	5.79	5.44	5.14	4.89	4.68	4.49	4.33	4.19	4.06	3.96	3.85	3.78	3.69	3.62
2.7	4.91	7.85	7.52	7.17	6.91	6.62	6.41	6.18	5.80	5.49	5.22	5.00	4.80	4.62	4.47	4.34	4.23	4.12	4.04	3.94	3.87
2.8	5.09	8.34	7.99	7.62	7.34	7.05	6.82	6.57	6.18	5.84	5.56	5.32	5.11	4.93	4.76	4.63	4.51	4.39	4.30	4.20	4.13
2.9	5.28	8.84	8.48	8.09	7.79	7.48	7.24	6.98	6.56	6.21	5.91	5.66	5.43	5.24	5.07	4.92	4.79	4.67	4.58	4.47	4.39
3.0	5.46	9.36	8.98	8.57	8.26	7.92	7.67	7.39	6.95	6.58	6.27	6.00	5.76	5.56	5.38	5.22	5.09	4.96	4.86	4.75	4.66
3.1	5.64	9.89	9.49	9.05	8.73	8.38	8.11	7.82	7.36	6.96	6.64	6.35	6.10	5.89	5.69	5.53	5.39	5.25	5.15	5.03	4.94
3.2	5.82	10.44	10.01	9.55	9.21	8.84	8.56	8.26	7.77	7.36	7.01	6.71	6.45	6.22	6.02	5.85	5.70	5.55	5.44	5.32	5.23
3.3	6.00	10.99	10.55	10.07	9.71	9.32	9.02	8.71	8.19	7.76	7.39	7.08	6.80	6.56	6.35	6.17	6.02	5.86	5.74	5.61	5.52
3.4	6.19	11.56	11.09	10.59	10.21	9.81	9.50	9.16	8.62	8.17	7.79	7.46	7.17	6.92	6.69	6.50	6.34	6.18	6.06	5.92	5.82
3.5	6.37	12.14	11.65	11.12	10.73	10.31	9.98	9.63	9.07	8.59	8.19	7.84	7.54	7.28	7.04	6.84	6.67	6.50	6.37	6.23	6.12
3.6	6.55	12.73	12.22	11.67	11.26	10.81	10.47	10.11	9.52	9.02	8.60	8.24	7.92	7.64	7.40	7.19	7.01	6.83	6.70	6.55	6.44
3.7	6.73	13.33	12.80	12.22	11.80	11.33	10.98	10.59	9.98	9.46	9.02	8.64	8.31	8.02	7.76	7.55	7.36	7.17	7.03	6.87	6.76
3.8	6.91	13.95	13.39	12.79	12.34	11.86	11.49	11.09	10.45	9.90	9.45	9.05	8.70	8.40	8.13	7.91	7.71	7.52	7.37	7.20	7.08
3.9	7.09	14.57	14.00	13.37	12.90	12.40	12.01	11.60	10.93	10.36	9.88	9.47	9.11	8.79	8.51	8.28	8.07	7.87	7.72	7.54	7.42
4.0	7.28	15.21	14.61	13.96	13.47	12.95	12.55	12.11	11.42	10.83	10.33	9.90	9.52	9.19	8.90	8.65	8.44	8.23	8.07	7.89	7.76
4.1	7.46	15.86	15.24	14.56	14.05	13.51	13.09	12.64	11.91	11.30	10.78	10.34	9.94	9.60	9.30	9.04	8.82	8.59	8.43	8.24	8.11
4.2	7.64	16.52	15.87	15.17	14.65	14.08	13.64	13.18	12.42	11.78	11.24	10.78	10.37	10.01	9.70	9.43	9.20	8.97	8.80	8.60	8.46
4.3	7.82	17.19	16.52	15.79	15.25	14.66	14.21	13.72	12.94	12.27	11.71	11.23	10.80	10.44	10.11	9.83	9.59	9.35	9.17	8.97	8.82
4.4	8.00	17.87	17.18	16.42	15.86	15.25	14.78	14.28	13.46	12.77	12.19	11.69	11.25	10.87	10.53	10.24	9.99	9.74	9.55	9.34	9.19
4.5	8.19	18.57	17.85	17.07	16.48	15.85	15.36	14.84	14.00	13.28	12.68	12.16	11.70	11.30	10.95	10.65	10.39	10.13	9.94	9.72	9.56
4.6	8.37	19.28	18.53	17.72	17.11	16.46	15.96	15.41	14.54	13.80	13.18	12.64	12.16	11.75	11.38	11.07	10.80	10.53	10.33	10.11	9.94
4.7	8.55	19.99	19.22	18.38	17.75	17.08	16.56	16.00	15.09	14.33	13.68	13.12	12.63	12.20	11.82	11.50	11.22	10.94	10.74	10.50	10.33
4.8	8.73	20.72	19.92	19.06	18.41	17.71	17.17	16.59	15.65	14.86	14.19	13.61	13.10	12.66	12.27	11.94	11.65	11.36	11.14	10.90	10.72

Continued on next page

Recommended Head Loss Design Range

5.5 ft./sec. is an industry standard for velocity limit in hydronic distribution systems.

Velocities in excess of 8 ft./sec. may cause erosion to metal components in the system.

Appendix D

Uponor PEX-a Hydronic Friction Loss Tables

1" Uponor PEX-a — 50% Propylene Glycol — Feet of Head per 100 Feet of Tubing

Velocity (ft./sec.)	GPM	40°F 4°C	45°F 7°C	50°F 10°C	55°F 13°C	60°F 16°C	65°F 18°C	70°F 21°C	80°F 27°C	90°F 32°C	100°F 38°C	110°F 43°C	120°F 49°C	130°F 54°C	140°F 60°C	150°F 66°C	160°F 71°C	170°F 77°C	180°F 82°C	190°F 88°C	200°F 93°C
4.9	8.91	21.46	20.64	19.74	19.07	18.35	17.79	17.19	16.22	15.40	14.71	14.11	13.58	13.13	12.72	12.38	12.08	11.78	11.56	11.31	11.12
5.0	9.10	22.21	21.36	20.43	19.74	18.99	18.42	17.80	16.80	15.95	15.24	14.62	14.07	13.61	13.18	12.83	12.52	12.21	11.98	11.72	11.53
5.1	9.28	22.97	22.09	21.14	20.42	19.65	19.06	18.42	17.39	16.51	15.78	15.14	14.57	14.09	13.65	13.28	12.97	12.65	12.41	12.14	11.94
5.2	9.46	23.74	22.84	21.85	21.12	20.32	19.71	19.05	17.99	17.08	16.32	15.66	15.08	14.58	14.13	13.75	13.42	13.09	12.84	12.57	12.36
5.3	9.64	24.53	23.59	22.58	21.82	21.00	20.37	19.69	18.59	17.66	16.87	16.19	15.59	15.08	14.61	14.22	13.88	13.54	13.29	13.00	12.79
5.4	9.82	25.32	24.36	23.31	22.53	21.69	21.04	20.34	19.20	18.24	17.44	16.73	16.11	15.58	15.10	14.70	14.35	14.00	13.73	13.44	13.22
5.5	10.01	26.12	25.14	24.06	23.25	22.38	21.71	20.99	19.83	18.84	18.00	17.28	16.64	16.09	15.60	15.18	14.82	14.46	14.19	13.88	13.66
5.6	10.19	26.94	25.92	24.81	23.99	23.09	22.40	21.66	20.46	19.44	18.58	17.84	17.18	16.61	16.10	15.67	15.30	14.93	14.65	14.34	14.11
5.7	10.37	27.76	26.72	25.58	24.73	23.81	23.10	22.33	21.10	20.05	19.17	18.40	17.72	17.14	16.62	16.17	15.79	15.40	15.12	14.80	14.56
5.8	10.55	28.60	27.53	26.35	25.48	24.53	23.80	23.02	21.75	20.67	19.76	18.97	18.27	17.67	17.13	16.68	16.28	15.89	15.59	15.26	15.02
5.9	10.73	29.45	28.34	27.14	26.24	25.26	24.52	23.71	22.40	21.29	20.36	19.55	18.83	18.21	17.66	17.19	16.78	16.38	16.07	15.73	15.48
6.0	10.92	30.31	29.17	27.93	27.01	26.01	25.24	24.41	23.07	21.93	20.97	20.13	19.39	18.76	18.19	17.71	17.29	16.87	16.56	16.21	15.95
6.1	11.10	31.17	30.01	28.74	27.79	26.76	25.97	25.12	23.74	22.57	21.58	20.73	19.97	19.32	18.73	18.24	17.81	17.38	17.06	16.69	16.43
6.2	11.28	32.05	30.86	29.55	28.58	27.52	26.71	25.84	24.42	23.22	22.21	21.33	20.55	19.88	19.28	18.77	18.33	17.89	17.56	17.19	16.91
6.3	11.46	32.94	31.71	30.38	29.38	28.30	27.46	26.57	25.11	23.88	22.84	21.94	21.13	20.45	19.83	19.31	18.86	18.40	18.06	17.68	17.40
6.4	11.64	33.84	32.58	31.21	30.19	29.08	28.22	27.30	25.81	24.55	23.48	22.55	21.73	21.02	20.39	19.86	19.39	18.92	18.58	18.19	17.90
6.5	11.82	34.75	33.46	32.06	31.01	29.87	28.99	28.05	26.52	25.22	24.12	23.17	22.33	21.61	20.96	20.41	19.93	19.45	19.10	18.70	18.40
6.6	12.01	35.67	34.35	32.91	31.83	30.67	29.77	28.80	27.23	25.90	24.78	23.81	22.94	22.20	21.53	20.97	20.48	19.99	19.62	19.21	18.91
6.7	12.19	36.60	35.25	33.77	32.67	31.47	30.55	29.56	27.96	26.59	25.44	24.44	23.56	22.80	22.11	21.54	21.03	20.53	20.16	19.73	19.42
6.8	12.37	37.54	36.15	34.65	33.52	32.29	31.35	30.33	28.69	27.29	26.11	25.09	24.18	23.40	22.70	22.11	21.60	21.08	20.70	20.26	19.95
6.9	12.55	38.49	37.07	35.53	34.37	33.12	32.15	31.11	29.43	28.00	26.79	25.74	24.81	24.01	23.30	22.69	22.16	21.63	21.24	20.80	20.47
7.0	12.73	39.45	38.00	36.42	35.24	33.95	32.97	31.90	30.18	28.71	27.48	26.40	25.45	24.63	23.90	23.28	22.74	22.20	21.79	21.34	21.01
7.1	12.92	40.42	38.94	37.32	36.11	34.80	33.79	32.70	30.94	29.44	28.17	27.07	26.09	25.26	24.51	23.87	23.32	22.76	22.35	21.89	21.54
7.2	13.10	41.40	39.89	38.23	36.99	35.65	34.62	33.51	31.70	30.17	28.87	27.75	26.75	25.89	25.12	24.47	23.91	23.34	22.92	22.44	22.09
7.3	13.28	42.39	40.84	39.15	37.89	36.51	35.46	34.32	32.47	30.90	29.58	28.43	27.41	26.53	25.74	25.08	24.50	23.92	23.49	23.00	22.64
7.4	13.46	43.39	41.81	40.08	38.79	37.39	36.31	35.14	33.25	31.65	30.29	29.12	28.07	27.18	26.37	25.69	25.10	24.51	24.06	23.56	23.20
7.5	13.64	44.40	42.79	41.02	39.70	38.27	37.16	35.97	34.04	32.40	31.02	29.82	28.75	27.83	27.01	26.31	25.71	25.10	24.65	24.14	23.76
7.6	13.83	45.43	43.77	41.97	40.62	39.15	38.03	36.81	34.84	33.16	31.75	30.52	29.43	28.49	27.65	26.94	26.32	25.70	25.24	24.71	24.33
7.7	14.01	46.46	44.77	42.93	41.55	40.05	38.90	37.66	35.65	33.93	32.49	31.23	30.12	29.16	28.30	27.57	26.94	26.30	25.83	25.30	24.91
7.8	14.19	47.50	45.77	43.89	42.49	40.96	39.78	38.52	36.46	34.71	33.23	31.95	30.81	29.83	28.96	28.21	27.56	26.92	26.43	25.89	25.49
7.9	14.37	48.55	46.79	44.87	43.43	41.87	40.67	39.38	37.28	35.50	33.99	32.68	31.51	30.51	29.62	28.86	28.20	27.53	27.04	26.48	26.08
8.0	14.55	49.61	47.81	45.86	44.39	42.80	41.57	40.25	38.11	36.29	34.75	33.41	32.22	31.20	30.29	29.51	28.84	28.16	27.66	27.09	26.67
8.1	14.74	50.66	48.81	46.81	45.25	43.69	42.48	41.16	39.03	37.16	35.58	34.22	33.00	32.00	31.09	30.28	29.60	28.91	28.40	27.82	27.39
8.2	14.92	51.72	49.83	47.77	46.17	44.56	43.32	41.98	39.94	38.00	36.38	35.00	33.76	32.74	31.82	31.00	30.31	29.62	29.10	28.52	28.09

Velocities in excess of 8 ft./sec. may cause erosion to metal components in the system.

5.5 ft./sec. is an industry standard for velocity limit in hydronic distribution systems.

Recommended Head Loss Design Range

Appendix E

MLC Hydronic Friction Loss Tables

1/2" Uponor MLC — 100% Water — Feet of Head per Foot of Tubing

Velocity (ft./sec.)	GPM	40°F 4°C	45°F 7°C	50°F 10°C	55°F 13°C	60°F 16°C	65°F 18°C	70°F 21°C	80°F 27°C	90°F 32°C	100°F 38°C	110°F 43°C	120°F 49°C	130°F 54°C	140°F 60°C	150°F 66°C	160°F 71°C	170°F 77°C	180°F 82°C	190°F 88°C	200°F 93°C
0.5	0.29	0.0060	0.0056	0.0052	0.0051	0.0050	0.0049	0.0048	0.0046	0.0044	0.0042	0.0041	0.0040	0.0039	0.0038	0.0037	0.0036	0.0036	0.0035	0.0034	0.0034
0.6	0.35	0.0081	0.0076	0.0071	0.0069	0.0067	0.0066	0.0065	0.0062	0.0060	0.0058	0.0056	0.0055	0.0053	0.0052	0.0051	0.0050	0.0049	0.0048	0.0047	0.0046
0.7	0.41	0.0105	0.0099	0.0092	0.0090	0.0087	0.0086	0.0084	0.0080	0.0078	0.0075	0.0073	0.0071	0.0069	0.0068	0.0066	0.0065	0.0063	0.0062	0.0061	0.0060
0.8	0.47	0.0131	0.0123	0.0115	0.0112	0.0109	0.0107	0.0105	0.0101	0.0097	0.0094	0.0092	0.0089	0.0087	0.0085	0.0083	0.0082	0.0080	0.0079	0.0077	0.0076
0.9	0.53	0.0159	0.0150	0.0140	0.0137	0.0134	0.0131	0.0128	0.0123	0.0119	0.0115	0.0112	0.0109	0.0107	0.0104	0.0102	0.0100	0.0098	0.0096	0.0095	0.0093
1.0	0.59	0.0190	0.0179	0.0167	0.0164	0.0160	0.0157	0.0153	0.0148	0.0143	0.0138	0.0134	0.0131	0.0128	0.0125	0.0122	0.0120	0.0118	0.0116	0.0114	0.0112
1.1	0.65	0.0223	0.0210	0.0197	0.0192	0.0188	0.0184	0.0180	0.0174	0.0168	0.0163	0.0158	0.0154	0.0151	0.0147	0.0144	0.0142	0.0139	0.0137	0.0134	0.0132
1.2	0.71	0.0258	0.0244	0.0228	0.0223	0.0218	0.0214	0.0209	0.0202	0.0195	0.0189	0.0184	0.0179	0.0175	0.0171	0.0168	0.0165	0.0162	0.0159	0.0156	0.0154
1.3	0.76	0.0295	0.0279	0.0261	0.0256	0.0250	0.0245	0.0240	0.0231	0.0224	0.0217	0.0211	0.0206	0.0201	0.0197	0.0193	0.0189	0.0186	0.0183	0.0180	0.0177
1.4	0.82	0.0334	0.0316	0.0296	0.0290	0.0284	0.0278	0.0273	0.0263	0.0255	0.0247	0.0240	0.0234	0.0229	0.0224	0.0219	0.0215	0.0212	0.0208	0.0205	0.0202
1.5	0.88	0.0376	0.0356	0.0333	0.0326	0.0319	0.0313	0.0307	0.0296	0.0287	0.0278	0.0271	0.0264	0.0258	0.0253	0.0248	0.0243	0.0239	0.0235	0.0231	0.0228
1.6	0.94	0.0419	0.0397	0.0372	0.0365	0.0356	0.0350	0.0343	0.0331	0.0321	0.0311	0.0303	0.0296	0.0289	0.0283	0.0277	0.0272	0.0267	0.0263	0.0259	0.0255
1.7	1.00	0.0465	0.0440	0.0413	0.0405	0.0396	0.0388	0.0381	0.0368	0.0356	0.0346	0.0337	0.0328	0.0321	0.0314	0.0308	0.0302	0.0297	0.0292	0.0288	0.0284
1.8	1.06	0.0512	0.0485	0.0456	0.0446	0.0436	0.0428	0.0420	0.0406	0.0393	0.0382	0.0372	0.0363	0.0355	0.0347	0.0340	0.0334	0.0328	0.0323	0.0318	0.0314
1.9	1.12	0.0561	0.0532	0.0500	0.0490	0.0479	0.0470	0.0461	0.0445	0.0432	0.0419	0.0409	0.0399	0.0390	0.0382	0.0374	0.0367	0.0361	0.0355	0.0350	0.0345
2.0	1.18	0.0612	0.0581	0.0546	0.0535	0.0523	0.0514	0.0504	0.0487	0.0472	0.0459	0.0447	0.0436	0.0426	0.0418	0.0409	0.0402	0.0395	0.0389	0.0383	0.0378
2.1	1.23	0.0666	0.0632	0.0594	0.0582	0.0569	0.0559	0.0548	0.0530	0.0514	0.0499	0.0486	0.0475	0.0464	0.0455	0.0446	0.0438	0.0431	0.0424	0.0418	0.0412
2.2	1.29	0.0721	0.0684	0.0643	0.0630	0.0617	0.0606	0.0594	0.0574	0.0557	0.0541	0.0528	0.0515	0.0504	0.0493	0.0484	0.0475	0.0467	0.0460	0.0453	0.0447
2.3	1.35	0.0777	0.0738	0.0694	0.0681	0.0666	0.0654	0.0642	0.0620	0.0602	0.0585	0.0570	0.0557	0.0544	0.0533	0.0523	0.0514	0.0505	0.0498	0.0490	0.0484
2.4	1.41	0.0836	0.0794	0.0747	0.0732	0.0717	0.0704	0.0691	0.0668	0.0648	0.0630	0.0614	0.0600	0.0587	0.0575	0.0564	0.0554	0.0545	0.0536	0.0529	0.0521
2.5	1.47	0.0897	0.0852	0.0802	0.0786	0.0769	0.0756	0.0742	0.0717	0.0696	0.0677	0.0660	0.0644	0.0630	0.0618	0.0606	0.0595	0.0585	0.0576	0.0568	0.0560
2.6	1.53	0.0959	0.0911	0.0858	0.0841	0.0823	0.0809	0.0794	0.0768	0.0745	0.0725	0.0706	0.0690	0.0675	0.0662	0.0649	0.0638	0.0627	0.0618	0.0609	0.0601
2.7	1.59	0.1023	0.0973	0.0916	0.0898	0.0879	0.0864	0.0848	0.0820	0.0796	0.0774	0.0755	0.0737	0.0721	0.0707	0.0694	0.0682	0.0671	0.0660	0.0651	0.0642
2.8	1.65	0.1089	0.1035	0.0975	0.0956	0.0936	0.0920	0.0903	0.0874	0.0848	0.0825	0.0804	0.0786	0.0769	0.0754	0.0740	0.0727	0.0715	0.0704	0.0694	0.0685
2.9	1.70	0.1157	0.1100	0.1036	0.1016	0.0995	0.0978	0.0960	0.0929	0.0902	0.0877	0.0855	0.0836	0.0818	0.0802	0.0787	0.0774	0.0761	0.0749	0.0739	0.0729
3.0	1.76	0.1226	0.1166	0.1099	0.1078	0.1056	0.1037	0.1018	0.0985	0.0957	0.0931	0.0908	0.0887	0.0868	0.0851	0.0836	0.0821	0.0808	0.0796	0.0784	0.0774
3.1	1.82	0.1297	0.1234	0.1163	0.1141	0.1117	0.1098	0.1078	0.1043	0.1013	0.0986	0.0962	0.0940	0.0920	0.0902	0.0885	0.0870	0.0856	0.0843	0.0831	0.0820
3.2	1.88	0.1370	0.1304	0.1229	0.1206	0.1181	0.1161	0.1139	0.1103	0.1071	0.1042	0.1017	0.0994	0.0973	0.0954	0.0936	0.0921	0.0906	0.0892	0.0880	0.0868
3.3	1.94	0.1444	0.1375	0.1296	0.1272	0.1246	0.1224	0.1202	0.1164	0.1130	0.1100	0.1073	0.1049	0.1027	0.1007	0.0989	0.0972	0.0956	0.0942	0.0929	0.0917
3.4	2.00	0.1521	0.1448	0.1365	0.1339	0.1312	0.1290	0.1266	0.1226	0.1191	0.1159	0.1131	0.1106	0.1083	0.1062	0.1042	0.1025	0.1008	0.0993	0.0979	0.0967
3.5	2.06	0.1598	0.1522	0.1436	0.1409	0.1380	0.1357	0.1332	0.1290	0.1253	0.1220	0.1190	0.1164	0.1139	0.1117	0.1097	0.1079	0.1061	0.1046	0.1031	0.1018
3.6	2.12	0.1678	0.1598	0.1508	0.1479	0.1450	0.1425	0.1399	0.1355	0.1316	0.1282	0.1251	0.1223	0.1197	0.1174	0.1153	0.1134	0.1116	0.1099	0.1084	0.1070
3.7	2.17	0.1759	0.1676	0.1582	0.1552	0.1521	0.1495	0.1468	0.1422	0.1381	0.1345	0.1313	0.1283	0.1257	0.1233	0.1211	0.1190	0.1171	0.1154	0.1138	0.1123

Continued on next page

Recommended Head Loss Design Range

Sizing in this region will lead to excessive head loss conditions.

Appendix E

MLC Hydronic Friction Loss Tables

1/2" Uponor MLC — 100% Water — Feet of Head per Foot of Tubing

Velocity (ft./sec.)	GPM	40°F 4°C	45°F 7°C	50°F 10°C	55°F 13°C	60°F 16°C	65°F 18°C	70°F 21°C	80°F 27°C	90°F 32°C	100°F 38°C	110°F 43°C	120°F 49°C	130°F 54°C	140°F 60°C	150°F 66°C	160°F 71°C	170°F 77°C	180°F 82°C	190°F 88°C	200°F 93°C
3.8	2.23	0.1842	0.1755	0.1657	0.1626	0.1593	0.1566	0.1538	0.1490	0.1447	0.1410	0.1376	0.1345	0.1317	0.1292	0.1269	0.1248	0.1228	0.1210	0.1194	0.1178
3.9	2.29	0.1927	0.1836	0.1733	0.1701	0.1667	0.1639	0.1610	0.1559	0.1515	0.1476	0.1440	0.1408	0.1379	0.1353	0.1329	0.1307	0.1286	0.1267	0.1250	0.1234
4.0	2.35	0.2013	0.1918	0.1811	0.1778	0.1742	0.1713	0.1682	0.1630	0.1584	0.1543	0.1506	0.1473	0.1442	0.1415	0.1390	0.1367	0.1345	0.1326	0.1308	0.1291
4.1	2.41	0.2101	0.2002	0.1891	0.1856	0.1819	0.1788	0.1757	0.1702	0.1654	0.1611	0.1573	0.1538	0.1507	0.1478	0.1452	0.1428	0.1406	0.1385	0.1366	0.1349
4.2	2.47	0.2190	0.2088	0.1972	0.1935	0.1897	0.1865	0.1832	0.1776	0.1726	0.1681	0.1641	0.1605	0.1573	0.1543	0.1515	0.1491	0.1467	0.1446	0.1426	0.1408
4.3	2.53	0.2281	0.2175	0.2055	0.2017	0.1977	0.1944	0.1910	0.1851	0.1799	0.1752	0.1711	0.1673	0.1639	0.1609	0.1580	0.1554	0.1530	0.1508	0.1487	0.1468
4.4	2.59	0.2374	0.2263	0.2139	0.2099	0.2058	0.2024	0.1988	0.1927	0.1873	0.1825	0.1782	0.1743	0.1708	0.1676	0.1646	0.1619	0.1594	0.1571	0.1550	0.1530
4.5	2.65	0.2468	0.2354	0.2224	0.2183	0.2140	0.2105	0.2068	0.2005	0.1949	0.1899	0.1854	0.1813	0.1777	0.1744	0.1713	0.1685	0.1659	0.1635	0.1613	0.1592
4.6	2.70	0.2564	0.2445	0.2311	0.2269	0.2224	0.2188	0.2149	0.2084	0.2026	0.1974	0.1927	0.1885	0.1847	0.1813	0.1781	0.1752	0.1725	0.1700	0.1677	0.1656

Appendix E

MLC Hydronic Friction Loss Tables

1/2" Uponor MLC — 30% Propylene Glycol — Feet of Head per Foot of Tubing

Velocity (ft./sec.)	GPM	40°F 4°C	45°F 7°C	50°F 10°C	55°F 13°C	60°F 16°C	65°F 18°C	70°F 21°C	80°F 27°C	90°F 32°C	100°F 38°C	110°F 43°C	120°F 49°C	130°F 54°C	140°F 60°C	150°F 66°C	160°F 71°C	170°F 77°C	180°F 82°C	190°F 88°C	200°F 93°C
0.5	0.29	0.0090	0.0086	0.0082	0.0078	0.0075	0.0072	0.0069	0.0064	0.0061	0.0057	0.0054	0.0052	0.0050	0.0048	0.0046	0.0045	0.0044	0.0042	0.0041	0.0041
0.6	0.35	0.0120	0.0115	0.0109	0.0105	0.0100	0.0097	0.0093	0.0087	0.0082	0.0077	0.0074	0.0070	0.0068	0.0065	0.0063	0.0061	0.0059	0.0058	0.0056	0.0055
0.7	0.41	0.0154	0.0147	0.0140	0.0135	0.0129	0.0124	0.0120	0.0112	0.0105	0.0100	0.0095	0.0091	0.0088	0.0084	0.0082	0.0079	0.0077	0.0075	0.0073	0.0072
0.8	0.47	0.0191	0.0183	0.0174	0.0167	0.0160	0.0155	0.0149	0.0140	0.0132	0.0125	0.0119	0.0114	0.0110	0.0106	0.0103	0.0099	0.0097	0.0094	0.0092	0.0090
0.9	0.53	0.0231	0.0221	0.0211	0.0203	0.0195	0.0188	0.0181	0.0170	0.0160	0.0152	0.0145	0.0139	0.0134	0.0129	0.0125	0.0122	0.0118	0.0115	0.0113	0.0111
1.0	0.59	0.0273	0.0262	0.0250	0.0241	0.0232	0.0224	0.0216	0.0202	0.0191	0.0182	0.0173	0.0166	0.0160	0.0154	0.0150	0.0146	0.0142	0.0138	0.0135	0.0133
1.1	0.65	0.0319	0.0306	0.0293	0.0282	0.0271	0.0262	0.0253	0.0237	0.0224	0.0213	0.0204	0.0195	0.0188	0.0182	0.0176	0.0171	0.0167	0.0163	0.0159	0.0156
1.2	0.71	0.0368	0.0353	0.0338	0.0326	0.0313	0.0303	0.0292	0.0274	0.0260	0.0247	0.0236	0.0227	0.0218	0.0211	0.0205	0.0199	0.0194	0.0189	0.0185	0.0182
1.3	0.76	0.0420	0.0403	0.0385	0.0372	0.0357	0.0346	0.0334	0.0314	0.0297	0.0283	0.0270	0.0260	0.0250	0.0242	0.0235	0.0228	0.0222	0.0217	0.0212	0.0209
1.4	0.82	0.0474	0.0455	0.0436	0.0420	0.0404	0.0391	0.0378	0.0356	0.0337	0.0320	0.0306	0.0295	0.0284	0.0274	0.0267	0.0259	0.0252	0.0247	0.0241	0.0237
1.5	0.88	0.0531	0.0510	0.0488	0.0471	0.0454	0.0439	0.0424	0.0399	0.0378	0.0360	0.0345	0.0331	0.0320	0.0309	0.0300	0.0292	0.0284	0.0278	0.0272	0.0267
1.6	0.94	0.0590	0.0568	0.0544	0.0525	0.0505	0.0489	0.0472	0.0445	0.0422	0.0402	0.0385	0.0370	0.0357	0.0345	0.0336	0.0326	0.0318	0.0311	0.0304	0.0299
1.7	1.00	0.0652	0.0628	0.0601	0.0581	0.0559	0.0542	0.0523	0.0493	0.0468	0.0446	0.0427	0.0411	0.0396	0.0383	0.0373	0.0363	0.0353	0.0345	0.0338	0.0332
1.8	1.06	0.0717	0.0690	0.0661	0.0639	0.0615	0.0596	0.0576	0.0543	0.0515	0.0491	0.0471	0.0453	0.0437	0.0423	0.0411	0.0400	0.0390	0.0381	0.0373	0.0367
1.9	1.12	0.0784	0.0755	0.0724	0.0699	0.0674	0.0653	0.0631	0.0595	0.0565	0.0539	0.0516	0.0497	0.0480	0.0464	0.0452	0.0439	0.0428	0.0419	0.0410	0.0403
2.0	1.18	0.0854	0.0822	0.0788	0.0762	0.0734	0.0712	0.0688	0.0649	0.0616	0.0588	0.0564	0.0543	0.0524	0.0507	0.0494	0.0480	0.0468	0.0458	0.0448	0.0441
2.1	1.23	0.0926	0.0892	0.0855	0.0827	0.0797	0.0773	0.0747	0.0706	0.0670	0.0639	0.0613	0.0590	0.0570	0.0552	0.0537	0.0523	0.0510	0.0499	0.0488	0.0480
2.2	1.29	0.1000	0.0964	0.0925	0.0894	0.0862	0.0836	0.0808	0.0764	0.0725	0.0692	0.0664	0.0639	0.0618	0.0598	0.0582	0.0567	0.0553	0.0541	0.0529	0.0521
2.3	1.35	0.1077	0.1038	0.0996	0.0964	0.0929	0.0901	0.0871	0.0824	0.0782	0.0747	0.0716	0.0690	0.0667	0.0646	0.0629	0.0612	0.0597	0.0584	0.0572	0.0563
2.4	1.41	0.1156	0.1115	0.1070	0.1035	0.0998	0.0968	0.0937	0.0885	0.0842	0.804	0.0771	0.0743	0.0718	0.0695	0.0677	0.0659	0.0643	0.0629	0.0616	0.0606
2.5	1.47	0.1238	0.1193	0.1146	0.1109	0.1069	0.1038	0.1004	0.0949	0.0902	0.862	0.0827	0.0797	0.0770	0.0746	0.0727	0.0708	0.0690	0.0676	0.0662	0.0651
2.6	1.53	0.1322	0.1274	0.1224	0.1184	0.1143	0.1109	0.1073	0.1015	0.0965	0.0922	0.885	0.0853	0.0825	0.0799	0.0778	0.0758	0.0739	0.0724	0.0709	0.0697
2.7	1.59	0.1408	0.1358	0.1304	0.1262	0.1218	0.1182	0.1144	0.1082	0.1030	0.0984	0.0944	0.0911	0.0880	0.0853	0.0831	0.0809	0.0790	0.0773	0.0757	0.0745
2.8	1.65	0.1496	0.1443	0.1386	0.1342	0.1295	0.1257	0.1217	0.1152	0.1096	0.1048	0.1005	0.0970	0.0938	0.0909	0.0885	0.0862	0.0842	0.0824	0.0807	0.0794
2.9	1.70	0.1587	0.1531	0.1471	0.1424	0.1375	0.1335	0.1292	0.1223	0.1164	0.1113	0.1068	0.1030	0.0997	0.0966	0.0941	0.0917	0.0895	0.0876	0.0858	0.0845
3.0	1.76	0.1680	0.1621	0.1558	0.1508	0.1456	0.1414	0.1369	0.1296	0.1234	0.1180	0.1133	0.1093	0.1057	0.1024	0.0998	0.0973	0.0949	0.0930	0.0911	0.0896
3.1	1.82	0.1775	0.1713	0.1646	0.1595	0.1539	0.1495	0.1448	0.1371	0.1305	0.1248	0.1199	0.1157	0.1119	0.1085	0.1057	0.1030	0.1006	0.0985	0.0965	0.0950
3.2	1.88	0.1872	0.1807	0.1737	0.1683	0.1625	0.1578	0.1528	0.1448	0.1378	0.1319	0.1266	0.1222	0.1182	0.1146	0.1117	0.1089	0.1063	0.1041	0.1020	0.1004
3.3	1.94	0.1972	0.1903	0.1830	0.1773	0.1712	0.1663	0.1611	0.1526	0.1453	0.1391	0.1336	0.1289	0.1247	0.1209	0.1179	0.1149	0.1122	0.1099	0.1077	0.1060
3.4	2.00	0.2073	0.2002	0.1925	0.1865	0.1801	0.1750	0.1695	0.1606	0.1530	0.1464	0.1407	0.1358	0.1314	0.1274	0.1242	0.1211	0.1182	0.1158	0.1135	0.1117
3.5	2.06	0.2177	0.2102	0.2021	0.1959	0.1892	0.1839	0.1781	0.1688	0.1608	0.1539	0.1479	0.1428	0.1382	0.1340	0.1307	0.1274	0.1244	0.1219	0.1194	0.1176
3.6	2.12	0.2283	0.2204	0.2120	0.2055	0.1985	0.1929	0.1869	0.1772	0.1688	0.1616	0.1553	0.1500	0.1452	0.1408	0.1373	0.1338	0.1307	0.1281	0.1255	0.1236
3.7	2.17	0.2391	0.2309	0.2221	0.2153	0.2080	0.2022	0.1959	0.1857	0.1770	0.1695	0.1629	0.1573	0.1523	0.1477	0.1440	0.1404	0.1371	0.1344	0.1317	0.1297

Continued on next page

Recommended Head Loss Design Range

Sizing in this region will lead to excessive head loss conditions.

Appendix E

MLC Hydronic Friction Loss Tables

1/2" Uponor MLC — 30% Propylene Glycol — Feet of Head per Foot of Tubing

Velocity (ft./sec.)	GPM	40°F 4°C	45°F 7°C	50°F 10°C	55°F 13°C	60°F 16°C	65°F 18°C	70°F 21°C	80°F 27°C	90°F 32°C	100°F 38°C	110°F 43°C	120°F 49°C	130°F 54°C	140°F 60°C	150°F 66°C	160°F 71°C	170°F 77°C	180°F 82°C	190°F 88°C	200°F 93°C
3.8	2.23	0.2501	0.2416	0.2324	0.2253	0.2177	0.2116	0.2051	0.1945	0.1853	0.1775	0.1706	0.1647	0.1595	0.1547	0.1509	0.1472	0.1437	0.1408	0.1380	0.1359
3.9	2.29	0.2613	0.2524	0.2429	0.2355	0.2276	0.2212	0.2144	0.2034	0.1938	0.1857	0.1785	0.1724	0.1669	0.1619	0.1579	0.1540	0.1504	0.1474	0.1445	0.1423
4.0	2.35	0.2727	0.2635	0.2536	0.2459	0.2376	0.2310	0.2239	0.2124	0.2025	0.1940	0.1865	0.1801	0.1744	0.1692	0.1651	0.1610	0.1573	0.1541	0.1511	0.1488
4.1	2.41	0.2844	0.2747	0.2644	0.2564	0.2479	0.2410	0.2336	0.2216	0.2113	0.2025	0.1947	0.1881	0.1821	0.1767	0.1724	0.1681	0.1642	0.1610	0.1578	0.1554
4.2	2.47	0.2962	0.2862	0.2755	0.2672	0.2583	0.2511	0.2435	0.2310	0.2203	0.2111	0.2030	0.1961	0.1900	0.1843	0.1798	0.1754	0.1714	0.1680	0.1646	0.1622

Appendix E

MLC Hydronic Friction Loss Tables

1/2" Uponor MLC — 40% Propylene Glycol — Feet of Head per Foot of Tubing

Velocity (ft./sec.)	GPM	40°F 4°C	45°F 7°C	50°F 10°C	55°F 13°C	60°F 16°C	65°F 18°C	70°F 21°C	80°F 27°C	90°F 32°C	100°F 38°C	110°F 43°C	120°F 49°C	130°F 54°C	140°F 60°C	150°F 66°C	160°F 71°C	170°F 77°C	180°F 82°C	190°F 88°C	200°F 93°C
0.5	0.29	0.0112	0.0105	0.0099	0.0094	0.0089	0.0085	0.0080	0.0074	0.0069	0.0064	0.0060	0.0057	0.0054	0.0052	0.0050	0.0048	0.0047	0.0049	0.0047	0.0046
0.6	0.35	0.0149	0.0140	0.0132	0.0125	0.0118	0.0113	0.0108	0.0099	0.0092	0.0086	0.0082	0.0077	0.0074	0.0071	0.0068	0.0066	0.0064	0.0066	0.0064	0.0063
0.7	0.41	0.0189	0.0179	0.0168	0.0160	0.0152	0.0145	0.0138	0.0128	0.0119	0.0111	0.0105	0.0100	0.0095	0.0091	0.0088	0.0085	0.0082	0.0086	0.0084	0.0081
0.8	0.47	0.0233	0.0221	0.0208	0.0198	0.0188	0.0180	0.0172	0.0159	0.0148	0.0139	0.0131	0.0125	0.0119	0.0114	0.0110	0.0107	0.0103	0.0108	0.0105	0.0102
0.9	0.53	0.0281	0.0267	0.0251	0.0240	0.0227	0.0218	0.0208	0.0193	0.0180	0.0169	0.0160	0.0152	0.0145	0.0140	0.0135	0.0130	0.0126	0.0132	0.0128	0.0125
1.0	0.59	0.0333	0.0316	0.0297	0.0284	0.0270	0.0259	0.0247	0.0229	0.0214	0.0201	0.0191	0.0182	0.0174	0.0167	0.0161	0.0156	0.0151	0.0157	0.0153	0.0149
1.1	0.65	0.0388	0.0368	0.0347	0.0331	0.0315	0.0302	0.0289	0.0268	0.0251	0.0236	0.0224	0.0213	0.0204	0.0196	0.0189	0.0183	0.0178	0.0185	0.0180	0.0175
1.2	0.71	0.0446	0.0423	0.0399	0.0382	0.0363	0.0349	0.0334	0.0310	0.0290	0.0273	0.0259	0.0247	0.0236	0.0227	0.0219	0.0213	0.0206	0.0215	0.0209	0.0204
1.3	0.76	0.0507	0.0482	0.0455	0.0435	0.0414	0.0398	0.0381	0.0354	0.0331	0.0313	0.0297	0.0283	0.0271	0.0260	0.0252	0.0244	0.0237	0.0246	0.0240	0.0234
1.4	0.82	0.0571	0.0543	0.0513	0.0491	0.0468	0.0450	0.0431	0.0400	0.0375	0.0354	0.0336	0.0320	0.0307	0.0295	0.0286	0.0277	0.0269	0.0280	0.0272	0.0265
1.5	0.88	0.0639	0.0608	0.0574	0.0550	0.0524	0.0504	0.0483	0.0449	0.0421	0.0398	0.0378	0.0360	0.0346	0.0332	0.0321	0.0312	0.0303	0.0315	0.0307	0.0299
1.6	0.94	0.0709	0.0675	0.0638	0.0611	0.0583	0.0561	0.0537	0.0500	0.0469	0.0443	0.0421	0.0402	0.0386	0.0371	0.0359	0.0349	0.0338	0.0352	0.0343	0.0334
1.7	1.00	0.0782	0.0745	0.0705	0.0676	0.0644	0.0620	0.0594	0.0554	0.0519	0.0491	0.0467	0.0446	0.0428	0.0412	0.0398	0.0387	0.0375	0.0390	0.0380	0.0371
1.8	1.06	0.0859	0.0818	0.0775	0.0742	0.0708	0.0682	0.0654	0.0609	0.0572	0.0541	0.0515	0.0491	0.0472	0.0454	0.0439	0.0427	0.0414	0.0431	0.0420	0.0409
1.9	1.12	0.0938	0.0894	0.0847	0.0812	0.0774	0.0746	0.0716	0.0667	0.0627	0.0593	0.0564	0.0539	0.0517	0.0498	0.0482	0.0469	0.0455	0.0473	0.0461	0.0449
2.0	1.18	0.1020	0.0972	0.0921	0.0884	0.0843	0.0812	0.0780	0.0727	0.0683	0.0647	0.0616	0.0588	0.0565	0.0544	0.0527	0.0512	0.0497	0.0516	0.0504	0.0491
2.1	1.23	0.1105	0.1054	0.0999	0.0958	0.0914	0.0881	0.0846	0.0789	0.0742	0.0703	0.0669	0.0639	0.0614	0.0592	0.0573	0.0557	0.0541	0.0562	0.0548	0.0534
2.2	1.29	0.1192	0.1137	0.1078	0.1035	0.0988	0.0952	0.0914	0.0854	0.0803	0.0761	0.0724	0.0692	0.0665	0.0641	0.0621	0.0604	0.0586	0.0609	0.0594	0.0579
2.3	1.35	0.1282	0.1224	0.1161	0.1114	0.1064	0.1026	0.0985	0.0920	0.0866	0.0820	0.0781	0.0747	0.0718	0.0692	0.0671	0.0652	0.0633	0.0657	0.0641	0.0626
2.4	1.41	0.1375	0.1313	0.1245	0.1196	0.1142	0.1102	0.1058	0.0989	0.0930	0.0882	0.0840	0.0804	0.0773	0.0745	0.0722	0.0702	0.0682	0.0708	0.0691	0.0674
2.5	1.47	0.1471	0.1404	0.1333	0.1280	0.1223	0.1180	0.1133	0.1059	0.0997	0.0946	0.0901	0.862	0.0829	0.0799	0.0775	0.0753	0.0732	0.0760	0.0741	0.0723
2.6	1.53	0.1569	0.1498	0.1422	0.1366	0.1306	0.1260	0.1211	0.1132	0.1066	0.1011	0.0964	0.0922	0.887	0.855	0.829	0.806	0.783	0.813	0.793	0.774
2.7	1.59	0.1670	0.1595	0.1515	0.1455	0.1391	0.1342	0.1290	0.1207	0.1137	0.1078	0.1028	0.984	0.947	0.913	0.885	0.861	0.836	0.868	0.847	0.827
2.8	1.65	0.1773	0.1694	0.1609	0.1546	0.1479	0.1427	0.1372	0.1283	0.1209	0.1147	0.1094	0.1048	0.1008	0.972	0.943	0.917	0.891	0.925	0.903	0.881
2.9	1.70	0.1879	0.1796	0.1706	0.1640	0.1568	0.1514	0.1455	0.1362	0.1284	0.1218	0.1162	0.1113	0.1071	0.1033	0.1002	0.974	0.947	0.983	0.959	0.937
3.0	1.76	0.1987	0.1900	0.1805	0.1735	0.1660	0.1603	0.1541	0.1443	0.1360	0.1291	0.1232	0.1180	0.1135	0.1096	0.1062	0.1034	0.1005	0.1042	0.1018	0.994
3.1	1.82	0.2098	0.2006	0.1907	0.1833	0.1754	0.1694	0.1629	0.1525	0.1439	0.1366	0.1303	0.1248	0.1202	0.1160	0.1125	0.1094	0.1064	0.1104	0.1078	0.1052
3.2	1.88	0.2211	0.2115	0.2011	0.1933	0.1850	0.1787	0.1719	0.1610	0.1519	0.1442	0.1377	0.1319	0.1269	0.1226	0.1188	0.1157	0.1125	0.1166	0.1139	0.1112
3.3	1.94	0.2327	0.2226	0.2117	0.2036	0.1949	0.1882	0.1811	0.1697	0.1601	0.1520	0.1451	0.1391	0.1339	0.1293	0.1254	0.1220	0.1187	0.1230	0.1202	0.1173
3.4	2.00	0.2445	0.2340	0.2225	0.2140	0.2049	0.1979	0.1905	0.1785	0.1684	0.1600	0.1528	0.1464	0.1410	0.1362	0.1321	0.1285	0.1250	0.1296	0.1266	0.1236
3.5	2.06	0.2566	0.2456	0.2336	0.2247	0.2152	0.2079	0.2001	0.1875	0.1770	0.1682	0.1606	0.1539	0.1483	0.1432	0.1389	0.1352	0.1315	0.1363	0.1332	0.1301
3.6	2.12	0.2689	0.2574	0.2449	0.2356	0.2256	0.2180	0.2099	0.1968	0.1858	0.1765	0.1686	0.1616	0.1557	0.1504	0.1459	0.1420	0.1382	0.1432	0.1399	0.1366
3.7	2.17	0.2815	0.2694	0.2564	0.2467	0.2363	0.2284	0.2199	0.2062	0.1947	0.1851	0.1768	0.1695	0.1633	0.1577	0.1530	0.1490	0.1449	0.1502	0.1467	0.1433
3.8	2.23	0.2943	0.2817	0.2681	0.2581	0.2472	0.2389	0.2301	0.2158	0.2038	0.1937	0.1851	0.1775	0.1710	0.1652	0.1603	0.1561	0.1519	0.1574	0.1537	0.1502
3.9	2.29	0.3073	0.2942	0.2801	0.2696	0.2583	0.2497	0.2404	0.2256	0.2131	0.2026	0.1936	0.1856	0.1789	0.1728	0.1677	0.1633	0.1589	0.1647	0.1609	0.1572
4.0	2.35	0.3205	0.3070	0.2923	0.2814	0.2696	0.2606	0.2510	0.2355	0.2225	0.2116	0.2023	0.1940	0.1869	0.1806	0.1753	0.1707	0.1661	0.1721	0.1682	0.1643

Appendix E

MLC Hydronic Friction Loss Tables

1/2" Uponor MLC — 50% Propylene Glycol — Feet of Head per Foot of Tubing

Velocity (ft./sec.)	GPM	40°F 4°C	45°F 7°C	50°F 10°C	55°F 13°C	60°F 16°C	65°F 18°C	70°F 21°C	80°F 27°C	90°F 32°C	100°F 38°C	110°F 43°C	120°F 49°C	130°F 54°C	140°F 60°C	150°F 66°C	160°F 71°C	170°F 77°C	180°F 82°C	190°F 88°C	200°F 93°C
0.5	0.29	0.0134	0.0125	0.0117	0.0110	0.0104	0.0099	0.0093	0.0085	0.0078	0.0072	0.0068	0.0064	0.0060	0.0057	0.0055	0.0053	0.0051	0.0049	0.0047	0.0046
0.6	0.35	0.0177	0.0166	0.0155	0.0147	0.0138	0.0131	0.0124	0.0114	0.0105	0.0097	0.0091	0.0086	0.0082	0.0078	0.0074	0.0071	0.0069	0.0066	0.0064	0.0063
0.7	0.41	0.0224	0.0211	0.0197	0.0187	0.0176	0.0168	0.0159	0.0146	0.0134	0.0125	0.0117	0.0111	0.0105	0.0100	0.0096	0.0092	0.0089	0.0086	0.0084	0.0081
0.8	0.47	0.0275	0.0260	0.0243	0.0231	0.0217	0.0208	0.0197	0.0181	0.0167	0.0156	0.0146	0.0138	0.0131	0.0125	0.0120	0.0116	0.0112	0.0108	0.0105	0.0102
0.9	0.53	0.0331	0.0312	0.0293	0.0278	0.0262	0.0251	0.0238	0.0219	0.0202	0.0189	0.0178	0.0168	0.0160	0.0153	0.0146	0.0141	0.0136	0.0132	0.0128	0.0125
1.0	0.59	0.0391	0.0369	0.0346	0.0329	0.0311	0.0297	0.0282	0.0260	0.0241	0.0225	0.0212	0.0200	0.0191	0.0182	0.0175	0.0169	0.0163	0.0157	0.0153	0.0149
1.1	0.65	0.0454	0.0429	0.0402	0.0383	0.0362	0.0346	0.0330	0.0303	0.0281	0.0263	0.0248	0.0235	0.0224	0.0214	0.0205	0.0198	0.0191	0.0185	0.0180	0.0175
1.2	0.71	0.0521	0.0493	0.0463	0.0440	0.0417	0.0399	0.0380	0.0350	0.0325	0.0304	0.0287	0.0272	0.0259	0.0248	0.0238	0.0230	0.0222	0.0215	0.0209	0.0204
1.3	0.76	0.0591	0.0560	0.0526	0.0501	0.0474	0.0454	0.0433	0.0399	0.0371	0.0348	0.0328	0.0311	0.0296	0.0284	0.0273	0.0263	0.0254	0.0246	0.0240	0.0234
1.4	0.82	0.0665	0.0630	0.0592	0.0565	0.0535	0.0512	0.0489	0.0451	0.0419	0.0393	0.0371	0.0352	0.0336	0.0322	0.0309	0.0299	0.0289	0.0280	0.0272	0.0265
1.5	0.88	0.0742	0.0704	0.0662	0.0631	0.0598	0.0574	0.0547	0.0505	0.0470	0.0441	0.0417	0.0396	0.0377	0.0362	0.0348	0.0336	0.0325	0.0315	0.0307	0.0299
1.6	0.94	0.0823	0.0780	0.0735	0.0701	0.0665	0.0637	0.0608	0.0562	0.0524	0.0492	0.0464	0.0441	0.0421	0.0404	0.0388	0.0375	0.0363	0.0352	0.0343	0.0334
1.7	1.00	0.0907	0.0861	0.0811	0.0774	0.0734	0.0704	0.0672	0.0622	0.0579	0.0544	0.0514	0.0489	0.0467	0.0447	0.0431	0.0416	0.0402	0.0390	0.0380	0.0371
1.8	1.06	0.0994	0.0944	0.0889	0.0849	0.0806	0.0773	0.0739	0.0683	0.0637	0.0599	0.0566	0.0538	0.0514	0.0493	0.0475	0.0459	0.0444	0.0431	0.0420	0.0409
1.9	1.12	0.1085	0.1030	0.0971	0.0927	0.0881	0.0845	0.0808	0.0748	0.0698	0.0656	0.0621	0.0590	0.0564	0.0541	0.0521	0.0503	0.0487	0.0473	0.0461	0.0449
2.0	1.18	0.1178	0.1119	0.1056	0.1009	0.0958	0.0920	0.0879	0.0814	0.0760	0.0715	0.0677	0.0644	0.0615	0.0590	0.0569	0.0550	0.0532	0.0516	0.0504	0.0491
2.1	1.23	0.1275	0.1211	0.1143	0.1093	0.1038	0.0997	0.0953	0.0883	0.0825	0.0776	0.0735	0.0699	0.0669	0.0642	0.0618	0.0598	0.0579	0.0562	0.0548	0.0534
2.2	1.29	0.1374	0.1306	0.1233	0.1179	0.1121	0.1077	0.1030	0.0955	0.0892	0.0840	0.0795	0.0757	0.0724	0.0695	0.0670	0.0648	0.0627	0.0609	0.0594	0.0579
2.3	1.35	0.1477	0.1404	0.1326	0.1268	0.1206	0.1159	0.1109	0.1028	0.0961	0.0905	0.0858	0.0816	0.0781	0.0750	0.0723	0.0699	0.0677	0.0657	0.0641	0.0626
2.4	1.41	0.1583	0.1505	0.1422	0.1360	0.1294	0.1244	0.1190	0.1104	0.1033	0.0973	0.0922	0.0878	0.0840	0.0807	0.0778	0.0752	0.0729	0.0708	0.0691	0.0674
2.5	1.47	0.1691	0.1609	0.1521	0.1455	0.1384	0.1331	0.1274	0.1183	0.1106	0.1042	0.0988	0.0941	0.0901	0.0865	0.0834	0.0807	0.0782	0.0760	0.0741	0.0723
2.6	1.53	0.1803	0.1716	0.1622	0.1552	0.1477	0.1421	0.1360	0.1263	0.1182	0.1114	0.1056	0.1006	0.0963	0.0925	0.0892	0.0864	0.0837	0.0813	0.0793	0.0774
2.7	1.59	0.1917	0.1825	0.1726	0.1652	0.1573	0.1513	0.1448	0.1346	0.1260	0.1187	0.1126	0.1073	0.1028	0.0987	0.0952	0.0922	0.0893	0.0868	0.0847	0.0827
2.8	1.65	0.2034	0.1937	0.1832	0.1754	0.1671	0.1607	0.1539	0.1430	0.1339	0.1263	0.1198	0.1142	0.1094	0.1051	0.1014	0.0982	0.0952	0.0925	0.0903	0.0881
2.9	1.70	0.2154	0.2052	0.1941	0.1859	0.1771	0.1704	0.1632	0.1517	0.1421	0.1341	0.1272	0.1213	0.1162	0.1117	0.1077	0.1043	0.1011	0.0983	0.0959	0.0937
3.0	1.76	0.2277	0.2169	0.2053	0.1966	0.1873	0.1803	0.1727	0.1606	0.1505	0.1420	0.1348	0.1285	0.1231	0.1184	0.1142	0.1106	0.1073	0.1042	0.1018	0.0994
3.1	1.82	0.2402	0.2289	0.2167	0.2076	0.1979	0.1904	0.1825	0.1698	0.1591	0.1502	0.1425	0.1360	0.1303	0.1253	0.1209	0.1171	0.1135	0.1104	0.1078	0.1052
3.2	1.88	0.2531	0.2412	0.2284	0.2189	0.2086	0.2008	0.1924	0.1791	0.1679	0.1585	0.1505	0.1436	0.1376	0.1323	0.1277	0.1237	0.1200	0.1166	0.1139	0.1112
3.3	1.94	0.2662	0.2537	0.2403	0.2303	0.2196	0.2114	0.2026	0.1886	0.1769	0.1670	0.1586	0.1514	0.1451	0.1395	0.1347	0.1305	0.1266	0.1230	0.1202	0.1173
3.4	2.00	0.2795	0.2665	0.2525	0.2420	0.2308	0.2222	0.2130	0.1984	0.1861	0.1757	0.1669	0.1593	0.1527	0.1469	0.1418	0.1374	0.1333	0.1296	0.1266	0.1236
3.5	2.06	0.2932	0.2796	0.2649	0.2540	0.2422	0.2333	0.2237	0.2084	0.1955	0.1847	0.1754	0.1675	0.1605	0.1545	0.1491	0.1445	0.1402	0.1363	0.1332	0.1301
3.6	2.12	0.3071	0.2929	0.2776	0.2662	0.2539	0.2446	0.2345	0.2185	0.2051	0.1937	0.1841	0.1758	0.1685	0.1622	0.1566	0.1517	0.1472	0.1432	0.1399	0.1366
3.7	2.17	0.3212	0.3065	0.2905	0.2786	0.2658	0.2561	0.2456	0.2289	0.2149	0.2030	0.1930	0.1842	0.1767	0.1700	0.1642	0.1591	0.1544	0.1502	0.1467	0.1433
3.8	2.23	0.3357	0.3203	0.3037	0.2913	0.2780	0.2678	0.2569	0.2395	0.2248	0.2125	0.2020	0.1929	0.1850	0.1781	0.1720	0.1667	0.1618	0.1574	0.1537	0.1502
3.9	2.29	0.3503	0.3344	0.3171	0.3042	0.2903	0.2797	0.2684	0.2503	0.2335	0.2221	0.2112	0.2017	0.1935	0.1863	0.1799	0.1744	0.1693	0.1647	0.1609	0.1572
4.0	2.35	0.3653	0.3487	0.3307	0.3173	0.3029	0.2919	0.2801	0.2612	0.2454	0.2320	0.2206	0.2107	0.2021	0.1946	0.1880	0.1823	0.1769	0.1721	0.1682	0.1643

Sizing in this region will lead to excessive head loss conditions.

Recommended Head Loss Design Range

Appendix E

MLC Hydronic Friction Loss Tables

5/8" Uponor MLC — 100% Water — Feet of Head per Foot of Tubing

Velocity (ft./sec.)	GPM	40°F 4°C	45°F 7°C	50°F 10°C	55°F 13°C	60°F 16°C	65°F 18°C	70°F 21°C	80°F 27°C	90°F 32°C	100°F 38°C	110°F 43°C	120°F 49°C	130°F 54°C	140°F 60°C	150°F 66°C	160°F 71°C	170°F 77°C	180°F 82°C	190°F 88°C	200°F 93°C
0.5	0.48	0.0043	0.0040	0.0038	0.0037	0.0036	0.0035	0.0034	0.0033	0.0032	0.0031	0.0030	0.0029	0.0028	0.0028	0.0027	0.0026	0.0026	0.0025	0.0025	0.0025
0.6	0.58	0.0058	0.0055	0.0051	0.0050	0.0049	0.0048	0.0047	0.0045	0.0043	0.0042	0.0041	0.0040	0.0039	0.0038	0.0037	0.0036	0.0036	0.0035	0.0034	0.0034
0.7	0.67	0.0075	0.0071	0.0066	0.0065	0.0063	0.0062	0.0061	0.0058	0.0056	0.0055	0.0053	0.0052	0.0050	0.0049	0.0048	0.0047	0.0046	0.0046	0.0045	0.0044
0.8	0.77	0.0094	0.0089	0.0083	0.0081	0.0079	0.0078	0.0076	0.0073	0.0071	0.0069	0.0067	0.0065	0.0063	0.0062	0.0061	0.0060	0.0058	0.0057	0.0057	0.0056
0.9	0.87	0.0115	0.0108	0.0101	0.0099	0.0097	0.0095	0.0093	0.0090	0.0087	0.0084	0.0082	0.0080	0.0078	0.0076	0.0075	0.0073	0.0072	0.0071	0.0069	0.0068
1.0	0.96	0.0137	0.0130	0.0121	0.0119	0.0116	0.0114	0.0111	0.0107	0.0104	0.0101	0.0098	0.0096	0.0093	0.0091	0.0090	0.0088	0.0086	0.0085	0.0083	0.0082
1.1	1.06	0.0161	0.0152	0.0143	0.0140	0.0137	0.0134	0.0131	0.0127	0.0123	0.0119	0.0116	0.0113	0.0110	0.0108	0.0106	0.0104	0.0102	0.0100	0.0099	0.0097
1.2	1.15	0.0187	0.0177	0.0166	0.0162	0.0159	0.0156	0.0152	0.0147	0.0142	0.0138	0.0135	0.0131	0.0128	0.0126	0.0123	0.0121	0.0119	0.0117	0.0115	0.0113
1.3	1.25	0.0214	0.0202	0.0190	0.0186	0.0182	0.0178	0.0175	0.0169	0.0164	0.0159	0.0155	0.0151	0.0147	0.0144	0.0141	0.0139	0.0136	0.0134	0.0132	0.0130
1.4	1.35	0.0242	0.0230	0.0216	0.0211	0.0207	0.0203	0.0199	0.0192	0.0186	0.0181	0.0176	0.0172	0.0168	0.0164	0.0161	0.0158	0.0155	0.0153	0.0151	0.0148
1.5	1.44	0.0272	0.0258	0.0243	0.0238	0.0233	0.0228	0.0224	0.0216	0.0210	0.0204	0.0198	0.0194	0.0189	0.0185	0.0182	0.0178	0.0175	0.0173	0.0170	0.0168
1.6	1.54	0.0304	0.0289	0.0271	0.0266	0.0260	0.0255	0.0250	0.0242	0.0234	0.0228	0.0222	0.0217	0.0212	0.0207	0.0203	0.0200	0.0196	0.0193	0.0190	0.0188
1.7	1.64	0.0337	0.0320	0.0301	0.0295	0.0289	0.0283	0.0278	0.0269	0.0260	0.0253	0.0247	0.0241	0.0236	0.0231	0.0226	0.0222	0.0218	0.0215	0.0212	0.0209
1.8	1.73	0.0372	0.0353	0.0332	0.0325	0.0319	0.0313	0.0307	0.0297	0.0288	0.0280	0.0273	0.0266	0.0260	0.0255	0.0250	0.0246	0.0242	0.0238	0.0234	0.0231
1.9	1.83	0.0408	0.0388	0.0365	0.0357	0.0350	0.0344	0.0337	0.0326	0.0316	0.0307	0.0300	0.0293	0.0286	0.0280	0.0275	0.0270	0.0266	0.0262	0.0258	0.0254
2.0	1.92	0.0445	0.0423	0.0398	0.0390	0.0382	0.0375	0.0368	0.0356	0.0346	0.0336	0.0328	0.0320	0.0313	0.0307	0.0301	0.0296	0.0291	0.0286	0.0282	0.0278
2.1	2.02	0.0484	0.0460	0.0433	0.0425	0.0416	0.0409	0.0401	0.0388	0.0376	0.0366	0.0357	0.0349	0.0341	0.0334	0.0328	0.0322	0.0317	0.0312	0.0308	0.0304
2.2	2.12	0.0524	0.0499	0.0470	0.0461	0.0451	0.0443	0.0435	0.0421	0.0408	0.0397	0.0387	0.0378	0.0370	0.0363	0.0356	0.0350	0.0344	0.0339	0.0334	0.0330
2.3	2.21	0.0566	0.0538	0.0507	0.0497	0.0487	0.0479	0.0470	0.0455	0.0441	0.0429	0.0419	0.0409	0.0400	0.0392	0.0385	0.0379	0.0372	0.0367	0.0361	0.0357
2.4	2.31	0.0609	0.0579	0.0546	0.0535	0.0524	0.0515	0.0506	0.0490	0.0475	0.0463	0.0451	0.0441	0.0431	0.0423	0.0415	0.0408	0.0401	0.0395	0.0390	0.0385
2.5	2.41	0.0653	0.0622	0.0586	0.0575	0.0563	0.0553	0.0543	0.0526	0.0511	0.0497	0.0485	0.0474	0.0464	0.0455	0.0446	0.0439	0.0431	0.0425	0.0419	0.0413
2.6	2.50	0.0699	0.0665	0.0627	0.0615	0.0603	0.0592	0.0582	0.0563	0.0547	0.0532	0.0519	0.0507	0.0497	0.0487	0.0478	0.0470	0.0462	0.0456	0.0449	0.0443
2.7	2.60	0.0746	0.0710	0.0670	0.0657	0.0644	0.0633	0.0621	0.0602	0.0584	0.0569	0.0555	0.0542	0.0531	0.0521	0.0511	0.0503	0.0494	0.0487	0.0480	0.0474
2.8	2.69	0.0794	0.0756	0.0713	0.0700	0.0686	0.0674	0.0662	0.0641	0.0623	0.0606	0.0592	0.0578	0.0566	0.0555	0.0545	0.0536	0.0527	0.0520	0.0512	0.0506
2.9	2.79	0.0844	0.0804	0.0758	0.0744	0.0729	0.0717	0.0704	0.0682	0.0662	0.0645	0.0629	0.0615	0.0602	0.0591	0.0580	0.0570	0.0561	0.0553	0.0545	0.0538
3.0	2.89	0.0894	0.0852	0.0804	0.0789	0.0773	0.0760	0.0747	0.0723	0.0703	0.0684	0.0668	0.0653	0.0640	0.0627	0.0616	0.0606	0.0596	0.0587	0.0579	0.0572
3.1	2.98	0.0947	0.0902	0.0852	0.0836	0.0819	0.0805	0.0791	0.0766	0.0744	0.0725	0.0708	0.0692	0.0678	0.0665	0.0653	0.0642	0.0632	0.0623	0.0614	0.0606
3.2	3.08	0.1000	0.0953	0.0900	0.0883	0.0866	0.0851	0.0836	0.0810	0.0787	0.0767	0.0748	0.0732	0.0717	0.0703	0.0691	0.0679	0.0668	0.0659	0.0650	0.0641
3.3	3.18	0.1055	0.1005	0.0950	0.0932	0.0913	0.0898	0.0882	0.0855	0.0831	0.0809	0.0790	0.0773	0.0757	0.0743	0.0729	0.0717	0.0706	0.0696	0.0686	0.0677
3.4	3.27	0.1111	0.1059	0.1000	0.0982	0.0962	0.0946	0.0930	0.0901	0.0876	0.0853	0.0833	0.0815	0.0798	0.0783	0.0769	0.0756	0.0744	0.0734	0.0724	0.0714
3.5	3.37	0.1168	0.1114	0.1052	0.1033	0.1012	0.0996	0.0978	0.0948	0.0921	0.0898	0.0877	0.0857	0.0840	0.0824	0.0810	0.0796	0.0784	0.0773	0.0762	0.0752
3.6	3.46	0.1226	0.1169	0.1105	0.1085	0.1064	0.1046	0.1028	0.0996	0.0968	0.0943	0.0921	0.0901	0.0883	0.0866	0.0851	0.0837	0.0824	0.0812	0.0801	0.0791
3.7	3.56	0.1286	0.1226	0.1159	0.1138	0.1116	0.1097	0.1078	0.1045	0.1016	0.0990	0.0967	0.0946	0.0927	0.0910	0.0894	0.0879	0.0865	0.0853	0.0841	0.0831

Continued on next page

Recommended Head Loss Design Range

Sizing in this region will lead to excessive head loss conditions.

Appendix E

MLC Hydronic Friction Loss Tables

5/8" Uponor MLC — 100% Water — Feet of Head per Foot of Tubing

Velocity (ft./sec.)	GPM	40°F 4°C	45°F 7°C	50°F 10°C	55°F 13°C	60°F 16°C	65°F 18°C	70°F 21°C	80°F 27°C	90°F 32°C	100°F 38°C	110°F 43°C	120°F 49°C	130°F 54°C	140°F 60°C	150°F 66°C	160°F 71°C	170°F 77°C	180°F 82°C	190°F 88°C	200°F 93°C
3.8	3.66	0.1347	0.1285	0.1215	0.1192	0.1169	0.1150	0.1130	0.1095	0.1065	0.1038	0.1014	0.0992	0.0972	0.0954	0.0937	0.0922	0.0907	0.0894	0.0882	0.0871
3.9	3.75	0.1409	0.1344	0.1271	0.1248	0.1224	0.1204	0.1183	0.1147	0.1115	0.1087	0.1061	0.1038	0.1017	0.0999	0.0981	0.0965	0.0950	0.0937	0.0924	0.0913
4.0	3.85	0.1472	0.1405	0.1328	0.1304	0.1279	0.1258	0.1236	0.1199	0.1166	0.1136	0.1110	0.1086	0.1064	0.1045	0.1026	0.1010	0.0994	0.0980	0.0967	0.0955
4.1	3.95	0.1537	0.1466	0.1387	0.1362	0.1336	0.1314	0.1291	0.1252	0.1218	0.1187	0.1159	0.1134	0.1112	0.1091	0.1072	0.1055	0.1039	0.1024	0.1011	0.0998
4.2	4.04	0.1602	0.1529	0.1447	0.1421	0.1393	0.1371	0.1347	0.1306	0.1271	0.1239	0.1210	0.1184	0.1160	0.1139	0.1119	0.1101	0.1085	0.1069	0.1055	0.1042
4.3	4.14	0.1669	0.1593	0.1508	0.1481	0.1452	0.1429	0.1404	0.1362	0.1325	0.1291	0.1261	0.1234	0.1210	0.1188	0.1167	0.1149	0.1131	0.1115	0.1100	0.1087
4.4	4.23	0.1737	0.1659	0.1570	0.1541	0.1512	0.1487	0.1462	0.1418	0.1379	0.1345	0.1314	0.1286	0.1260	0.1237	0.1216	0.1197	0.1178	0.1162	0.1147	0.1132
4.5	4.33	0.1806	0.1725	0.1633	0.1603	0.1573	0.1547	0.1521	0.1475	0.1435	0.1399	0.1367	0.1338	0.1312	0.1288	0.1266	0.1246	0.1227	0.1209	0.1194	0.1179
4.6	4.43	0.1877	0.1792	0.1697	0.1666	0.1635	0.1608	0.1581	0.1534	0.1492	0.1455	0.1422	0.1391	0.1364	0.1339	0.1316	0.1295	0.1276	0.1258	0.1241	0.1226
4.7	4.52	0.1949	0.1861	0.1762	0.1730	0.1698	0.1670	0.1642	0.1593	0.1550	0.1511	0.1477	0.1446	0.1417	0.1391	0.1368	0.1346	0.1326	0.1307	0.1290	0.1274
4.8	4.62	0.2021	0.1931	0.1828	0.1796	0.1762	0.1733	0.1704	0.1653	0.1609	0.1569	0.1533	0.1501	0.1471	0.1445	0.1420	0.1398	0.1376	0.1357	0.1340	0.1323
4.9	4.72	0.2095	0.2002	0.1895	0.1862	0.1827	0.1797	0.1767	0.1715	0.1668	0.1627	0.1590	0.1557	0.1526	0.1499	0.1473	0.1450	0.1428	0.1408	0.1390	0.1373
5.0	4.81	0.2170	0.2074	0.1964	0.1929	0.1893	0.1863	0.1831	0.1777	0.1729	0.1686	0.1648	0.1614	0.1582	0.1554	0.1527	0.1503	0.1481	0.1460	0.1441	0.1424
5.1	4.91	0.2247	0.2147	0.2033	0.1997	0.1960	0.1929	0.1896	0.1840	0.1791	0.1747	0.1707	0.1671	0.1639	0.1609	0.1582	0.1557	0.1534	0.1513	0.1493	0.1475
5.2	5.00	0.2324	0.2221	0.2104	0.2067	0.2028	0.1996	0.1962	0.1904	0.1854	0.1808	0.1767	0.1730	0.1697	0.1666	0.1638	0.1612	0.1588	0.1566	0.1546	0.1527
5.3	5.10	0.2402	0.2296	0.2175	0.2137	0.2097	0.2064	0.2029	0.1970	0.1917	0.1870	0.1828	0.1790	0.1755	0.1724	0.1695	0.1668	0.1643	0.1621	0.1600	0.1580
5.4	5.20	0.2482	0.2372	0.2248	0.2209	0.2167	0.2133	0.2097	0.2036	0.1982	0.1933	0.1890	0.1850	0.1815	0.1782	0.1752	0.1725	0.1699	0.1676	0.1654	0.1634

Appendix E

MLC Hydronic Friction Loss Tables

5/8" Uponor MLC — 30% Propylene Glycol — Feet of Head per Foot of Tubing

Velocity (ft./sec.)	GPM	40°F 4°C	45°F 7°C	50°F 10°C	55°F 13°C	60°F 16°C	65°F 18°C	70°F 21°C	80°F 27°C	90°F 32°C	100°F 38°C	110°F 43°C	120°F 49°C	130°F 54°C	140°F 60°C	150°F 66°C	160°F 71°C	170°F 77°C	180°F 82°C	190°F 88°C	200°F 93°C
0.5	0.48	0.0064	0.0061	0.0058	0.0056	0.0053	0.0051	0.0049	0.0046	0.0043	0.0041	0.0039	0.0037	0.0036	0.0035	0.0034	0.0032	0.0032	0.0031	0.0030	0.0029
0.6	0.58	0.0085	0.0082	0.0078	0.0075	0.0072	0.0069	0.0066	0.0062	0.0059	0.0056	0.0053	0.0051	0.0049	0.0047	0.0046	0.0044	0.0043	0.0042	0.0041	0.0040
0.7	0.67	0.0109	0.0105	0.0100	0.0096	0.0092	0.0089	0.0086	0.0080	0.0076	0.0072	0.0069	0.0066	0.0063	0.0061	0.0059	0.0058	0.0056	0.0055	0.0053	0.0052
0.8	0.77	0.0136	0.0130	0.0124	0.0120	0.0115	0.0111	0.0107	0.0100	0.0095	0.0090	0.0086	0.0083	0.0079	0.0077	0.0074	0.0072	0.0070	0.0069	0.0067	0.0066
0.9	0.87	0.0164	0.0158	0.0151	0.0145	0.0140	0.0135	0.0130	0.0122	0.0116	0.0110	0.0105	0.0101	0.0097	0.0094	0.0091	0.0088	0.0086	0.0084	0.0082	0.0081
1.0	0.96	0.0195	0.0187	0.0179	0.0173	0.0166	0.0161	0.0155	0.0146	0.0138	0.0131	0.0125	0.0121	0.0116	0.0112	0.0109	0.0106	0.0103	0.0101	0.0098	0.0097
1.1	1.06	0.0228	0.0219	0.0210	0.0202	0.0195	0.0188	0.0182	0.0171	0.0162	0.0154	0.0148	0.0142	0.0137	0.0132	0.0128	0.0125	0.0122	0.0119	0.0116	0.0114
1.2	1.15	0.0263	0.0253	0.0242	0.0234	0.0225	0.0218	0.0210	0.0198	0.0188	0.0179	0.0171	0.0165	0.0159	0.0153	0.0149	0.0145	0.0141	0.0138	0.0135	0.0133
1.3	1.25	0.0300	0.0289	0.0277	0.0267	0.0257	0.0249	0.0241	0.0227	0.0215	0.0205	0.0196	0.0189	0.0182	0.0176	0.0171	0.0167	0.0162	0.0159	0.0155	0.0153
1.4	1.35	0.0340	0.0327	0.0313	0.0302	0.0291	0.0282	0.0273	0.0257	0.0244	0.0233	0.0223	0.0214	0.0207	0.0200	0.0195	0.0189	0.0185	0.0180	0.0176	0.0174
1.5	1.44	0.0381	0.0366	0.0351	0.0339	0.0327	0.0317	0.0306	0.0289	0.0274	0.0262	0.0251	0.0241	0.0233	0.0225	0.0219	0.0213	0.0208	0.0203	0.0199	0.0196
1.6	1.54	0.0424	0.0408	0.0391	0.0378	0.0364	0.0353	0.0342	0.0322	0.0306	0.0292	0.0280	0.0270	0.0260	0.0252	0.0245	0.0239	0.0233	0.0228	0.0223	0.0219
1.7	1.64	0.0469	0.0451	0.0433	0.0419	0.0404	0.0391	0.0378	0.0357	0.0339	0.0324	0.0311	0.0299	0.0289	0.0280	0.0272	0.0265	0.0258	0.0253	0.0248	0.0243
1.8	1.73	0.0515	0.0497	0.0476	0.0461	0.0444	0.0431	0.0417	0.0394	0.0374	0.0357	0.0343	0.0330	0.0319	0.0309	0.0301	0.0293	0.0286	0.0279	0.0273	0.0269
1.9	1.83	0.0564	0.0544	0.0522	0.0505	0.0487	0.0472	0.0457	0.0432	0.0411	0.0392	0.0376	0.0362	0.0350	0.0339	0.0330	0.0322	0.0314	0.0307	0.0301	0.0296
2.0	1.92	0.0614	0.0592	0.0569	0.0550	0.0531	0.0515	0.0498	0.0471	0.0448	0.0428	0.0411	0.0396	0.0383	0.0371	0.0361	0.0352	0.0343	0.0336	0.0329	0.0324
2.1	2.02	0.0667	0.0643	0.0617	0.0598	0.0577	0.0560	0.0542	0.0512	0.0487	0.0466	0.0447	0.0431	0.0417	0.0404	0.0393	0.0383	0.0374	0.0366	0.0358	0.0352
2.2	2.12	0.0721	0.0695	0.0668	0.0646	0.0624	0.0606	0.0586	0.0555	0.0528	0.0504	0.0484	0.0467	0.0452	0.0437	0.0426	0.0415	0.0405	0.0397	0.0389	0.0382
2.3	2.21	0.0776	0.0749	0.0720	0.0697	0.0673	0.0653	0.0632	0.0599	0.0570	0.0545	0.0523	0.0504	0.0488	0.0473	0.0461	0.0449	0.0438	0.0429	0.0420	0.0413
2.4	2.31	0.0834	0.0805	0.0773	0.0749	0.0723	0.0702	0.0680	0.0644	0.0613	0.0586	0.0563	0.0543	0.0525	0.0509	0.0496	0.0483	0.0472	0.0462	0.0453	0.0445
2.5	2.41	0.0893	0.0862	0.0828	0.0803	0.0775	0.0753	0.0729	0.0690	0.0657	0.0629	0.0604	0.0583	0.0564	0.0547	0.0533	0.0519	0.0507	0.0496	0.0486	0.0479
2.6	2.50	0.0954	0.0921	0.0885	0.0858	0.0828	0.0805	0.0779	0.0738	0.0703	0.0673	0.0646	0.0624	0.0604	0.0585	0.0570	0.0556	0.0543	0.0532	0.0521	0.0513
2.7	2.60	0.1016	0.0981	0.0944	0.0914	0.0883	0.0858	0.0831	0.0788	0.0750	0.0718	0.0690	0.0666	0.0645	0.0625	0.0609	0.0594	0.0580	0.0568	0.0557	0.0548
2.8	2.69	0.1081	0.1044	0.1004	0.0973	0.0940	0.0913	0.0885	0.0839	0.0799	0.0765	0.0735	0.0709	0.0687	0.0666	0.0649	0.0633	0.0618	0.0606	0.0593	0.0584
2.9	2.79	0.1147	0.1107	0.1065	0.1033	0.0998	0.0969	0.0939	0.0891	0.0849	0.0813	0.0781	0.0754	0.0730	0.0708	0.0690	0.0673	0.0657	0.0644	0.0631	0.0621
3.0	2.89	0.1214	0.1173	0.1128	0.1094	0.1057	0.1027	0.0996	0.0944	0.0900	0.0862	0.0828	0.0800	0.0774	0.0751	0.0733	0.0714	0.0698	0.0684	0.0670	0.0660
3.1	2.98	0.1283	0.1240	0.1193	0.1157	0.1118	0.1087	0.1053	0.0999	0.0952	0.0912	0.0877	0.0847	0.0820	0.0796	0.0776	0.0757	0.0739	0.0724	0.0710	0.0699
3.2	3.08	0.1354	0.1308	0.1259	0.1221	0.1180	0.1147	0.1112	0.1055	0.1006	0.0964	0.0927	0.0895	0.0867	0.0841	0.0820	0.0800	0.0781	0.0766	0.0751	0.0739
3.3	3.18	0.1426	0.1378	0.1327	0.1287	0.1244	0.1209	0.1172	0.1113	0.1061	0.1017	0.0978	0.0944	0.0915	0.0888	0.0866	0.0845	0.0825	0.0809	0.0792	0.0781
3.4	3.27	0.1500	0.1450	0.1396	0.1354	0.1309	0.1273	0.1234	0.1171	0.1117	0.1071	0.1030	0.0995	0.0964	0.0935	0.0912	0.0890	0.0869	0.0852	0.0835	0.0823
3.5	3.37	0.1576	0.1523	0.1467	0.1423	0.1376	0.1338	0.1297	0.1231	0.1175	0.1126	0.1083	0.1046	0.1014	0.0984	0.0960	0.0937	0.0915	0.0897	0.0879	0.0866
3.6	3.46	0.1653	0.1598	0.1539	0.1493	0.1444	0.1404	0.1362	0.1293	0.1234	0.1182	0.1137	0.1099	0.1065	0.1034	0.1009	0.0984	0.0961	0.0943	0.0924	0.0910
3.7	3.56	0.1732	0.1674	0.1612	0.1564	0.1513	0.1472	0.1427	0.1355	0.1293	0.1240	0.1193	0.1153	0.1117	0.1085	0.1058	0.1033	0.1009	0.0989	0.0970	0.0955
3.8	3.66	0.1812	0.1752	0.1687	0.1637	0.1584	0.1541	0.1494	0.1419	0.1355	0.1299	0.1250	0.1208	0.1171	0.1136	0.1109	0.1082	0.1058	0.1037	0.1017	0.1002

Continued on next page

Recommended Head Loss Design Range

Sizing in this region will lead to excessive head loss conditions.

Appendix E

MLC Hydronic Friction Loss Tables

5/8" Uponor MLC — 30% Propylene Glycol — Feet of Head per Foot of Tubing

Velocity (ft./sec.)	GPM	40°F 4°C	45°F 7°C	50°F 10°C	55°F 13°C	60°F 16°C	65°F 18°C	70°F 21°C	80°F 27°C	90°F 32°C	100°F 38°C	110°F 43°C	120°F 49°C	130°F 54°C	140°F 60°C	150°F 66°C	160°F 71°C	170°F 77°C	180°F 82°C	190°F 88°C	200°F 93°C
3.9	3.75	0.1893	0.1831	0.1764	0.1712	0.1656	0.1611	0.1563	0.1485	0.1417	0.1359	0.1308	0.1264	0.1225	0.1189	0.1161	0.1133	0.1107	0.1086	0.1064	0.1049
4.0	3.85	0.1977	0.1912	0.1842	0.1788	0.1729	0.1683	0.1632	0.1551	0.1481	0.1420	0.1367	0.1321	0.1281	0.1244	0.1214	0.1185	0.1158	0.1135	0.1113	0.1097
4.1	3.95	0.2061	0.1994	0.1921	0.1865	0.1804	0.1756	0.1703	0.1619	0.1546	0.1482	0.1427	0.1380	0.1337	0.1299	0.1268	0.1237	0.1209	0.1186	0.1163	0.1146
4.2	4.04	0.2148	0.2077	0.2002	0.1943	0.1881	0.1830	0.1776	0.1688	0.1612	0.1546	0.1488	0.1439	0.1395	0.1355	0.1323	0.1291	0.1262	0.1238	0.1214	0.1196
4.3	4.14	0.2235	0.2163	0.2084	0.2023	0.1958	0.1906	0.1849	0.1758	0.1679	0.1611	0.1551	0.1500	0.1454	0.1412	0.1379	0.1346	0.1315	0.1290	0.1265	0.1247
4.4	4.23	0.2325	0.2249	0.2168	0.2105	0.2037	0.1983	0.1924	0.1829	0.1747	0.1677	0.1614	0.1561	0.1514	0.1470	0.1435	0.1401	0.1370	0.1344	0.1318	0.1299
4.5	4.33	0.2415	0.2337	0.2253	0.2188	0.2118	0.2061	0.2000	0.1902	0.1817	0.1744	0.1679	0.1624	0.1575	0.1530	0.1493	0.1458	0.1425	0.1398	0.1371	0.1351
4.6	4.43	0.2508	0.2427	0.2340	0.2272	0.2199	0.2141	0.2078	0.1976	0.1888	0.1812	0.1745	0.1688	0.1637	0.1590	0.1552	0.1516	0.1482	0.1454	0.1426	0.1405
4.7	4.52	0.2601	0.2517	0.2427	0.2357	0.2282	0.2221	0.2157	0.2051	0.1960	0.1881	0.1812	0.1753	0.1700	0.1651	0.1612	0.1574	0.1539	0.1510	0.1481	0.1460
4.8	4.62	0.2696	0.2610	0.2517	0.2444	0.2366	0.2304	0.2237	0.2127	0.2033	0.1951	0.1880	0.1819	0.1764	0.1714	0.1673	0.1634	0.1598	0.1567	0.1537	0.1515
4.9	4.72	0.2793	0.2704	0.2607	0.2532	0.2452	0.2387	0.2318	0.2205	0.2107	0.2023	0.1949	0.1886	0.1829	0.1777	0.1735	0.1695	0.1657	0.1626	0.1595	0.1572
5.0	4.81	0.2891	0.2799	0.2699	0.2622	0.2539	0.2472	0.2400	0.2284	0.2183	0.2096	0.2019	0.1954	0.1895	0.1841	0.1798	0.1756	0.1717	0.1685	0.1653	0.1629

Recommended Head Loss Design Range

Sizing in this region will lead to excessive head loss conditions.

Appendix E

MLC Hydronic Friction Loss Tables

5/8" Uponor MLC — 40% Propylene Glycol — Feet of Head per Foot of Tubing

Velocity (ft./sec.)	GPM	40°F 4°C	45°F 7°C	50°F 10°C	55°F 13°C	60°F 16°C	65°F 18°C	70°F 21°C	80°F 27°C	90°F 32°C	100°F 38°C	110°F 43°C	120°F 49°C	130°F 54°C	140°F 60°C	150°F 66°C	160°F 71°C	170°F 77°C	180°F 82°C	190°F 88°C	200°F 93°C	
0.5	0.48	0.0078	0.0074	0.0070	0.0066	0.0063	0.0060	0.0057	0.0053	0.0049	0.0046	0.0043	0.0041	0.0039	0.0038	0.0036	0.0035	0.0034	0.0034	0.0035	0.0034	0.0033
0.6	0.58	0.0104	0.0099	0.0093	0.0089	0.0084	0.0080	0.0077	0.0071	0.0066	0.0062	0.0059	0.0056	0.0053	0.0051	0.0049	0.0048	0.0046	0.0046	0.0047	0.0047	0.0045
0.7	0.67	0.0133	0.0126	0.0119	0.0113	0.0108	0.0103	0.0099	0.0091	0.0085	0.0080	0.0076	0.0072	0.0069	0.0066	0.0064	0.0062	0.0060	0.0061	0.0061	0.0061	0.0059
0.8	0.77	0.0165	0.0156	0.0147	0.0141	0.0134	0.0128	0.0123	0.0114	0.0106	0.0100	0.0095	0.0090	0.0086	0.0083	0.0080	0.0077	0.0075	0.0076	0.0076	0.0076	0.0074
0.9	0.87	0.0199	0.0189	0.0178	0.0170	0.0162	0.0156	0.0149	0.0138	0.0129	0.0122	0.0115	0.0110	0.0105	0.0101	0.0098	0.0095	0.0092	0.0093	0.0093	0.0093	0.0091
1.0	0.96	0.0236	0.0224	0.0212	0.0202	0.0193	0.0185	0.0177	0.0164	0.0154	0.0145	0.0138	0.0131	0.0126	0.0121	0.0117	0.0113	0.0110	0.0111	0.0111	0.0111	0.0108
1.1	1.06	0.0275	0.0262	0.0247	0.0236	0.0225	0.0217	0.0207	0.0193	0.0181	0.0170	0.0162	0.0154	0.0148	0.0142	0.0138	0.0133	0.0129	0.0131	0.0131	0.0131	0.0128
1.2	1.15	0.0317	0.0301	0.0285	0.0273	0.0260	0.0250	0.0240	0.0223	0.0209	0.0197	0.0188	0.0179	0.0172	0.0165	0.0160	0.0155	0.0150	0.0152	0.0152	0.0152	0.0148
1.3	1.25	0.0360	0.0343	0.0325	0.0311	0.0297	0.0285	0.0274	0.0255	0.0239	0.0226	0.0215	0.0205	0.0197	0.0189	0.0183	0.0178	0.0172	0.0175	0.0175	0.0175	0.0170
1.4	1.35	0.0407	0.0387	0.0367	0.0352	0.0335	0.0323	0.0310	0.0288	0.0271	0.0256	0.0244	0.0233	0.0223	0.0215	0.0208	0.0202	0.0196	0.0204	0.0204	0.0204	0.0194
1.5	1.44	0.0455	0.0434	0.0411	0.0394	0.0376	0.0362	0.0347	0.0324	0.0304	0.0288	0.0274	0.0262	0.0251	0.0242	0.0234	0.0227	0.0221	0.0230	0.0230	0.0230	0.0218
1.6	1.54	0.0506	0.0482	0.0457	0.0438	0.0418	0.0403	0.0387	0.0361	0.0339	0.0321	0.0306	0.0292	0.0281	0.0270	0.0262	0.0254	0.0247	0.0257	0.0257	0.0257	0.0244
1.7	1.64	0.0558	0.0533	0.0505	0.0485	0.0463	0.0446	0.0428	0.0400	0.0376	0.0356	0.0339	0.0324	0.0311	0.0300	0.0291	0.0282	0.0274	0.0285	0.0285	0.0285	0.0271
1.8	1.73	0.0613	0.0585	0.0555	0.0533	0.0509	0.0491	0.0471	0.0440	0.0414	0.0392	0.0374	0.0357	0.0344	0.0331	0.0321	0.0312	0.0303	0.0314	0.0314	0.0314	0.0299
1.9	1.83	0.0670	0.0640	0.0607	0.0583	0.0557	0.0537	0.0516	0.0482	0.0454	0.0430	0.0410	0.0392	0.0377	0.0363	0.0352	0.0342	0.0333	0.0345	0.0345	0.0345	0.0329
2.0	1.92	0.0729	0.0697	0.0661	0.0635	0.0607	0.0586	0.0563	0.0526	0.0495	0.0470	0.0448	0.0428	0.0412	0.0397	0.0385	0.0374	0.0364	0.0377	0.0377	0.0377	0.0359
2.1	2.02	0.0791	0.0755	0.0717	0.0689	0.0659	0.0635	0.0611	0.0571	0.0538	0.0510	0.0487	0.0466	0.0448	0.0432	0.0419	0.0407	0.0396	0.0411	0.0411	0.0411	0.0391
2.2	2.12	0.0854	0.0816	0.0775	0.0745	0.0712	0.0687	0.0661	0.0618	0.0582	0.0553	0.0527	0.0504	0.0485	0.0468	0.0454	0.0441	0.0429	0.0445	0.0445	0.0445	0.0424
2.3	2.21	0.0919	0.0878	0.0834	0.0802	0.0767	0.0741	0.0712	0.0666	0.0628	0.0596	0.0569	0.0545	0.0524	0.0506	0.0490	0.0477	0.0464	0.0481	0.0481	0.0481	0.0458
2.4	2.31	0.0986	0.0943	0.0896	0.0861	0.0824	0.0796	0.0765	0.0716	0.0675	0.0641	0.0612	0.0586	0.0564	0.0544	0.0528	0.0514	0.0499	0.0518	0.0518	0.0518	0.0494
2.5	2.41	0.1055	0.1009	0.0959	0.0922	0.0883	0.0852	0.0820	0.0768	0.0724	0.0688	0.0656	0.0629	0.0605	0.0584	0.0567	0.0551	0.0536	0.0556	0.0556	0.0556	0.0530
2.6	2.50	0.1126	0.1077	0.1024	0.0985	0.0943	0.0911	0.0876	0.0821	0.0774	0.0736	0.0702	0.0673	0.0648	0.0625	0.0607	0.0590	0.0574	0.0595	0.0595	0.0595	0.0568
2.7	2.60	0.1199	0.1147	0.1091	0.1049	0.1005	0.0971	0.0934	0.0875	0.0826	0.0785	0.0749	0.0718	0.0692	0.0668	0.0648	0.0631	0.0613	0.0636	0.0636	0.0636	0.0606
2.8	2.69	0.1273	0.1219	0.1159	0.1115	0.1068	0.1032	0.0993	0.0931	0.0879	0.0835	0.0798	0.0765	0.0737	0.0711	0.0690	0.0672	0.0653	0.0677	0.0677	0.0677	0.0646
2.9	2.79	0.1350	0.1292	0.1230	0.1183	0.1133	0.1095	0.1054	0.0989	0.0934	0.0887	0.0848	0.0813	0.0783	0.0756	0.0734	0.0714	0.0695	0.0720	0.0720	0.0720	0.0687
3.0	2.89	0.1428	0.1367	0.1302	0.1253	0.1200	0.1160	0.1117	0.1048	0.0989	0.0941	0.0899	0.0862	0.0830	0.0802	0.0778	0.0758	0.0737	0.0764	0.0764	0.0764	0.0729
3.1	2.98	0.1509	0.1445	0.1375	0.1324	0.1269	0.1226	0.1181	0.1108	0.1047	0.0995	0.0951	0.0912	0.0879	0.0849	0.0824	0.0802	0.0781	0.0809	0.0809	0.0809	0.0772
3.2	3.08	0.1591	0.1523	0.1451	0.1397	0.1339	0.1294	0.1246	0.1170	0.1105	0.1051	0.1005	0.0964	0.0929	0.0897	0.0871	0.0848	0.0826	0.0855	0.0855	0.0855	0.0817
3.3	3.18	0.1674	0.1604	0.1528	0.1471	0.1410	0.1363	0.1313	0.1233	0.1165	0.1109	0.1060	0.1017	0.0980	0.0947	0.0919	0.0895	0.0871	0.0902	0.0902	0.0902	0.0862
3.4	3.27	0.1760	0.1686	0.1607	0.1547	0.1483	0.1434	0.1382	0.1298	0.1227	0.1167	0.1116	0.1071	0.1032	0.0998	0.0968	0.0943	0.0918	0.0951	0.0951	0.0951	0.0908
3.5	3.37	0.1848	0.1771	0.1687	0.1625	0.1558	0.1507	0.1452	0.1364	0.1289	0.1227	0.1173	0.1126	0.1085	0.1049	0.1019	0.0992	0.0966	0.1000	0.1000	0.1000	0.0956
3.6	3.46	0.1937	0.1856	0.1769	0.1704	0.1634	0.1581	0.1523	0.1431	0.1353	0.1288	0.1232	0.1182	0.1140	0.1102	0.1070	0.1043	0.1015	0.1051	0.1051	0.1051	0.1004
3.7	3.56	0.2028	0.1944	0.1853	0.1785	0.1712	0.1656	0.1596	0.1500	0.1419	0.1351	0.1292	0.1240	0.1196	0.1156	0.1123	0.1094	0.1065	0.1103	0.1103	0.1103	0.1054
3.8	3.66	0.2121	0.2033	0.1938	0.1868	0.1791	0.1733	0.1671	0.1570	0.1485	0.1414	0.1353	0.1299	0.1253	0.1211	0.1176	0.1146	0.1116	0.1155	0.1155	0.1155	0.1104

Continued on next page

Recommended Head Loss Design Range

Sizing in this region will lead to excessive head loss conditions.

Appendix E

MLC Hydronic Friction Loss Tables

5/8" Uponor MLC — 40% Propylene Glycol — Feet of Head per Foot of Tubing

Velocity (ft./sec.)	GPM	40°F 4°C	45°F 7°C	50°F 10°C	55°F 13°C	60°F 16°C	65°F 18°C	70°F 21°C	80°F 27°C	90°F 32°C	100°F 38°C	110°F 43°C	120°F 49°C	130°F 54°C	140°F 60°C	150°F 66°C	160°F 71°C	170°F 77°C	180°F 82°C	190°F 88°C	200°F 93°C
3.9	3.75	0.2215	0.2124	0.2025	0.1952	0.1872	0.1812	0.1747	0.1642	0.1553	0.1479	0.1415	0.1359	0.1311	0.1267	0.1231	0.1200	0.1168	0.1209	0.1182	0.1156
4.0	3.85	0.2311	0.2216	0.2114	0.2037	0.1955	0.1892	0.1824	0.1715	0.1623	0.1546	0.1479	0.1420	0.1370	0.1325	0.1287	0.1254	0.1221	0.1264	0.1236	0.1208
4.1	3.95	0.2409	0.2311	0.2204	0.2124	0.2039	0.1973	0.1903	0.1789	0.1693	0.1613	0.1544	0.1482	0.1430	0.1383	0.1344	0.1310	0.1275	0.1320	0.1291	0.1262
4.2	4.04	0.2509	0.2406	0.2296	0.2213	0.2124	0.2056	0.1983	0.1865	0.1765	0.1682	0.1610	0.1546	0.1492	0.1443	0.1402	0.1366	0.1331	0.1377	0.1347	0.1317
4.3	4.14	0.2610	0.2504	0.2389	0.2303	0.2211	0.2140	0.2064	0.1942	0.1838	0.1752	0.1677	0.1611	0.1554	0.1504	0.1461	0.1424	0.1387	0.1435	0.1403	0.1372
4.4	4.23	0.2713	0.2603	0.2484	0.2395	0.2299	0.2226	0.2147	0.2020	0.1913	0.1823	0.1745	0.1676	0.1618	0.1565	0.1521	0.1483	0.1444	0.1494	0.1461	0.1429
4.5	4.33	0.2818	0.2704	0.2580	0.2488	0.2389	0.2313	0.2231	0.2100	0.1989	0.1895	0.1815	0.1743	0.1683	0.1628	0.1582	0.1542	0.1503	0.1554	0.1520	0.1487
4.6	4.43	0.2924	0.2806	0.2678	0.2583	0.2480	0.2402	0.2317	0.2181	0.2066	0.1969	0.1886	0.1812	0.1749	0.1692	0.1644	0.1603	0.1562	0.1616	0.1580	0.1546
4.7	4.52	0.3032	0.2910	0.2778	0.2679	0.2573	0.2492	0.2404	0.2263	0.2144	0.2044	0.1957	0.1881	0.1816	0.1757	0.1708	0.1665	0.1622	0.1678	0.1641	0.1605

Appendix E

MLC Hydronic Friction Loss Tables

5/8" Uponor MLC — 50% Propylene Glycol — Feet of Head per Foot of Tubing

Velocity (ft./sec.)	GPM	40°F 4°C	45°F 7°C	50°F 10°C	55°F 13°C	60°F 16°C	65°F 18°C	70°F 21°C	80°F 27°C	90°F 32°C	100°F 38°C	110°F 43°C	120°F 49°C	130°F 54°C	140°F 60°C	150°F 66°C	160°F 71°C	170°F 77°C	180°F 82°C	190°F 88°C	200°F 93°C
0.5	0.48	0.0093	0.0088	0.0082	0.0077	0.0073	0.0069	0.0066	0.0060	0.0055	0.0052	0.0048	0.0046	0.0043	0.0041	0.0039	0.0038	0.0037	0.0035	0.0034	0.0033
0.6	0.58	0.0123	0.0116	0.0109	0.0103	0.0097	0.0093	0.0088	0.0081	0.0075	0.0069	0.0065	0.0062	0.0059	0.0056	0.0054	0.0052	0.0050	0.0048	0.0047	0.0045
0.7	0.67	0.0157	0.0148	0.0139	0.0132	0.0124	0.0119	0.0113	0.0104	0.0096	0.0090	0.0084	0.0080	0.0076	0.0072	0.0069	0.0067	0.0064	0.0062	0.0061	0.0059
0.8	0.77	0.0193	0.0183	0.0171	0.0163	0.0154	0.0147	0.0140	0.0129	0.0119	0.0112	0.0105	0.0099	0.0095	0.0090	0.0087	0.0084	0.0081	0.0078	0.0076	0.0074
0.9	0.87	0.0233	0.0220	0.0207	0.0197	0.0186	0.0178	0.0170	0.0156	0.0145	0.0136	0.0128	0.0121	0.0115	0.0110	0.0106	0.0102	0.0099	0.0096	0.0093	0.0091
1.0	0.96	0.0275	0.0260	0.0245	0.0233	0.0221	0.0211	0.0201	0.0186	0.0172	0.0162	0.0152	0.0145	0.0138	0.0132	0.0127	0.0122	0.0118	0.0114	0.0111	0.0108
1.1	1.06	0.0320	0.0303	0.0285	0.0272	0.0258	0.0247	0.0235	0.0217	0.0202	0.0189	0.0179	0.0170	0.0162	0.0155	0.0149	0.0144	0.0139	0.0135	0.0131	0.0128
1.2	1.15	0.0368	0.0349	0.0328	0.0313	0.0297	0.0284	0.0271	0.0251	0.0233	0.0219	0.0207	0.0196	0.0187	0.0180	0.0173	0.0167	0.0161	0.0156	0.0152	0.0148
1.3	1.25	0.0418	0.0397	0.0374	0.0356	0.0338	0.0324	0.0310	0.0286	0.0267	0.0250	0.0237	0.0225	0.0215	0.0206	0.0198	0.0191	0.0185	0.0179	0.0175	0.0170
1.4	1.35	0.0471	0.0447	0.0421	0.0402	0.0382	0.0366	0.0350	0.0324	0.0302	0.0284	0.0268	0.0255	0.0243	0.0233	0.0225	0.0217	0.0210	0.0204	0.0199	0.0194
1.5	1.44	0.0526	0.0500	0.0471	0.0450	0.0427	0.0410	0.0392	0.0363	0.0339	0.0318	0.0301	0.0286	0.0274	0.0263	0.0253	0.0244	0.0237	0.0230	0.0224	0.0218
1.6	1.54	0.0584	0.0555	0.0523	0.0500	0.0475	0.0456	0.0436	0.0404	0.0377	0.0355	0.0336	0.0320	0.0306	0.0293	0.0282	0.0273	0.0264	0.0257	0.0250	0.0244
1.7	1.64	0.0644	0.0612	0.0578	0.0552	0.0525	0.0504	0.0482	0.0447	0.0418	0.0393	0.0372	0.0354	0.0339	0.0325	0.0313	0.0303	0.0293	0.0285	0.0278	0.0271
1.8	1.73	0.0707	0.0672	0.0635	0.0607	0.0577	0.0554	0.0530	0.0492	0.0460	0.0433	0.0410	0.0391	0.0374	0.0359	0.0346	0.0334	0.0324	0.0314	0.0307	0.0299
1.9	1.83	0.0771	0.0734	0.0693	0.0663	0.0631	0.0606	0.0580	0.0539	0.0504	0.0474	0.0450	0.0428	0.0410	0.0393	0.0379	0.0367	0.0356	0.0345	0.0337	0.0329
2.0	1.92	0.0838	0.0798	0.0754	0.0722	0.0687	0.0660	0.0632	0.0587	0.0549	0.0517	0.0491	0.0467	0.0447	0.0430	0.0414	0.0401	0.0389	0.0377	0.0368	0.0359
2.1	2.02	0.0908	0.0864	0.0817	0.0782	0.0745	0.0716	0.0686	0.0637	0.0596	0.0562	0.0533	0.0508	0.0486	0.0467	0.0451	0.0436	0.0423	0.0411	0.0401	0.0391
2.2	2.12	0.0979	0.0933	0.0882	0.0845	0.0804	0.0774	0.0741	0.0689	0.0645	0.0608	0.0577	0.0550	0.0527	0.0506	0.0488	0.0473	0.0458	0.0445	0.0435	0.0424
2.3	2.21	0.1053	0.1003	0.0949	0.0909	0.0866	0.0833	0.0798	0.0742	0.0695	0.0656	0.0622	0.0594	0.0568	0.0546	0.0527	0.0510	0.0495	0.0481	0.0470	0.0458
2.4	2.31	0.1129	0.1076	0.1018	0.0976	0.0930	0.0895	0.0857	0.0797	0.0747	0.0705	0.0669	0.0638	0.0612	0.0588	0.0567	0.0550	0.0533	0.0518	0.0506	0.0494
2.5	2.41	0.1207	0.1150	0.1089	0.1044	0.0995	0.0958	0.0918	0.0854	0.0801	0.0756	0.0718	0.0685	0.0656	0.0631	0.0609	0.0590	0.0572	0.0556	0.0543	0.0530
2.6	2.50	0.1287	0.1227	0.1162	0.1114	0.1062	0.1023	0.0980	0.0913	0.0856	0.0808	0.0767	0.0732	0.0702	0.0675	0.0652	0.0631	0.0612	0.0595	0.0581	0.0568
2.7	2.60	0.1370	0.1306	0.1237	0.1186	0.1131	0.1089	0.1044	0.0973	0.0913	0.0862	0.0819	0.0781	0.0749	0.0721	0.0696	0.0674	0.0654	0.0636	0.0621	0.0606
2.8	2.69	0.1454	0.1387	0.1314	0.1260	0.1202	0.1158	0.1110	0.1034	0.0971	0.0917	0.0871	0.0832	0.0797	0.0767	0.0741	0.0718	0.0697	0.0677	0.0662	0.0646
2.9	2.79	0.1540	0.1470	0.1393	0.1336	0.1275	0.1228	0.1178	0.1098	0.1030	0.0974	0.0925	0.0884	0.0847	0.0815	0.0787	0.0763	0.0740	0.0720	0.0703	0.0687
3.0	2.89	0.1629	0.1554	0.1474	0.1414	0.1349	0.1300	0.1247	0.1163	0.1092	0.1032	0.0981	0.0937	0.0898	0.0865	0.0835	0.0809	0.0786	0.0764	0.0746	0.0729
3.1	2.98	0.1719	0.1641	0.1557	0.1493	0.1425	0.1374	0.1318	0.1229	0.1154	0.1091	0.1037	0.0991	0.0951	0.0915	0.0884	0.0857	0.0832	0.0809	0.0790	0.0772
3.2	3.08	0.1812	0.1730	0.1641	0.1575	0.1503	0.1449	0.1390	0.1297	0.1218	0.1152	0.1096	0.1047	0.1004	0.0967	0.0934	0.0906	0.0879	0.0855	0.0836	0.0817
3.3	3.18	0.1906	0.1820	0.1727	0.1658	0.1583	0.1526	0.1465	0.1367	0.1284	0.1214	0.1155	0.1104	0.1059	0.1020	0.0986	0.0955	0.0928	0.0902	0.0882	0.0862
3.4	3.27	0.2003	0.1913	0.1816	0.1743	0.1664	0.1604	0.1540	0.1438	0.1351	0.1278	0.1216	0.1162	0.1115	0.1074	0.1038	0.1006	0.0977	0.0951	0.0929	0.0908
3.5	3.37	0.2101	0.2007	0.1906	0.1829	0.1747	0.1685	0.1618	0.1510	0.1420	0.1343	0.1278	0.1222	0.1173	0.1129	0.1092	0.1059	0.1028	0.1000	0.0978	0.0956
3.6	3.46	0.2202	0.2104	0.1997	0.1918	0.1832	0.1767	0.1697	0.1584	0.1490	0.1410	0.1342	0.1283	0.1231	0.1186	0.1147	0.1112	0.1080	0.1051	0.1027	0.1004
3.7	3.56	0.2304	0.2202	0.2091	0.2008	0.1919	0.1850	0.1777	0.1660	0.1561	0.1478	0.1407	0.1345	0.1291	0.1244	0.1203	0.1166	0.1133	0.1103	0.1078	0.1054
3.8	3.66	0.2408	0.2302	0.2186	0.2100	0.2007	0.1936	0.1859	0.1737	0.1634	0.1547	0.1473	0.1408	0.1352	0.1303	0.1260	0.1222	0.1187	0.1155	0.1129	0.1104

Continued on next page

Recommended Head Loss Design Range

Sizing in this region will lead to excessive head loss conditions.

Appendix E

MLC Hydronic Friction Loss Tables

5/8" Uponor MLC — 50% Propylene Glycol — Feet of Head per Foot of Tubing

Velocity (ft./sec.)	GPM	40°F 4°C	45°F 7°C	50°F 10°C	55°F 13°C	60°F 16°C	65°F 18°C	70°F 21°C	80°F 27°C	90°F 32°C	100°F 38°C	110°F 43°C	120°F 49°C	130°F 54°C	140°F 60°C	150°F 66°C	160°F 71°C	170°F 77°C	180°F 82°C	190°F 88°C	200°F 93°C
3.9	3.75	0.2514	0.2404	0.2283	0.2193	0.2097	0.2023	0.1943	0.1816	0.1708	0.1618	0.1540	0.1473	0.1415	0.1363	0.1318	0.1279	0.1242	0.1209	0.1182	0.1156
4.0	3.85	0.2622	0.2507	0.2382	0.2289	0.2188	0.2111	0.2028	0.1896	0.1784	0.1690	0.1609	0.1539	0.1478	0.1424	0.1378	0.1337	0.1298	0.1264	0.1236	0.1208
4.1	3.95	0.2732	0.2613	0.2483	0.2386	0.2281	0.2201	0.2115	0.1977	0.1861	0.1763	0.1679	0.1606	0.1543	0.1487	0.1438	0.1395	0.1356	0.1320	0.1291	0.1262
4.2	4.04	0.2844	0.2720	0.2585	0.2485	0.2376	0.2293	0.2203	0.2060	0.1940	0.1837	0.1750	0.1675	0.1609	0.1551	0.1500	0.1456	0.1414	0.1377	0.1347	0.1317
4.3	4.14	0.2958	0.2829	0.2689	0.2585	0.2472	0.2386	0.2293	0.2145	0.2019	0.1913	0.1823	0.1744	0.1676	0.1616	0.1563	0.1517	0.1474	0.1435	0.1403	0.1372
4.4	4.23	0.3073	0.2940	0.2795	0.2687	0.2570	0.2481	0.2385	0.2231	0.2101	0.1991	0.1897	0.1815	0.1744	0.1682	0.1627	0.1579	0.1534	0.1494	0.1461	0.1429
4.5	4.33	0.3191	0.3053	0.2903	0.2791	0.2670	0.2577	0.2478	0.2318	0.2183	0.2069	0.1972	0.1887	0.1814	0.1749	0.1692	0.1642	0.1596	0.1554	0.1520	0.1487
4.6	4.43	0.3310	0.3167	0.3012	0.2896	0.2771	0.2675	0.2572	0.2407	0.2267	0.2149	0.2048	0.1961	0.1885	0.1817	0.1758	0.1707	0.1659	0.1616	0.1580	0.1546
4.7	4.52	0.3431	0.3283	0.3123	0.3003	0.2873	0.2774	0.2668	0.2497	0.2353	0.2230	0.2126	0.2035	0.1956	0.1887	0.1826	0.1772	0.1723	0.1678	0.1641	0.1605

Appendix E

MLC Hydronic Friction Loss Tables

3/4" Uponor MLC — 100% Water — Feet of Head per Foot of Tubing

Velocity (ft./sec.)	GPM	40°F / 4°C	45°F / 7°C	50°F / 10°C	55°F / 13°C	60°F / 16°C	65°F / 18°C	70°F / 21°C	80°F / 27°C	90°F / 32°C	100°F / 38°C	110°F / 43°C	120°F / 49°C	130°F / 54°C	140°F / 60°C	150°F / 66°C	160°F / 71°C	170°F / 77°C	180°F / 82°C	190°F / 88°C	200°F / 93°C	
0.5	0.77	0.0031	0.0030	0.0028	0.0027	0.0026	0.0025	0.0024	0.0023	0.0023	0.0023	0.0022	0.0021	0.0021	0.0020	0.0020	0.0020	0.0019	0.0019	0.0019	0.0019	0.0018
0.6	0.92	0.0043	0.0040	0.0038	0.0037	0.0036	0.0035	0.0034	0.0033	0.0032	0.0032	0.0031	0.0030	0.0029	0.0028	0.0027	0.0027	0.0026	0.0026	0.0026	0.0026	0.0025
0.7	1.08	0.0055	0.0052	0.0049	0.0048	0.0047	0.0046	0.0045	0.0043	0.0042	0.0042	0.0040	0.0039	0.0038	0.0037	0.0036	0.0035	0.0035	0.0034	0.0033	0.0033	0.0033
0.8	1.23	0.0069	0.0065	0.0061	0.0060	0.0059	0.0057	0.0056	0.0054	0.0053	0.0051	0.0050	0.0048	0.0047	0.0046	0.0045	0.0044	0.0044	0.0043	0.0042	0.0042	0.0042
0.9	1.38	0.0084	0.0080	0.0075	0.0073	0.0072	0.0070	0.0069	0.0066	0.0064	0.0062	0.0061	0.0059	0.0058	0.0057	0.0056	0.0054	0.0054	0.0053	0.0052	0.0051	0.0051
1.0	1.54	0.0101	0.0096	0.0090	0.0088	0.0086	0.0084	0.0083	0.0080	0.0077	0.0075	0.0073	0.0071	0.0070	0.0068	0.0067	0.0065	0.0064	0.0063	0.0062	0.0061	0.0061
1.1	1.69	0.0119	0.0112	0.0106	0.0103	0.0101	0.0099	0.0097	0.0094	0.0091	0.0088	0.0086	0.0084	0.0082	0.0080	0.0079	0.0077	0.0076	0.0075	0.0074	0.0073	0.0073
1.2	1.84	0.0138	0.0131	0.0123	0.0120	0.0117	0.0115	0.0113	0.0109	0.0106	0.0103	0.0100	0.0098	0.0096	0.0094	0.0092	0.0090	0.0089	0.0087	0.0086	0.0085	0.0085
1.3	2.00	0.0158	0.0150	0.0141	0.0138	0.0135	0.0132	0.0130	0.0125	0.0122	0.0118	0.0115	0.0112	0.0110	0.0108	0.0106	0.0104	0.0102	0.0100	0.0099	0.0097	0.0097
1.4	2.15	0.0179	0.0170	0.0160	0.0157	0.0153	0.0150	0.0148	0.0143	0.0138	0.0135	0.0131	0.0128	0.0125	0.0123	0.0120	0.0118	0.0116	0.0114	0.0113	0.0111	0.0111
1.5	2.30	0.0201	0.0191	0.0180	0.0176	0.0173	0.0170	0.0166	0.0161	0.0156	0.0152	0.0148	0.0144	0.0141	0.0138	0.0136	0.0133	0.0131	0.0129	0.0127	0.0125	0.0125
1.6	2.46	0.0225	0.0214	0.0201	0.0197	0.0193	0.0190	0.0186	0.0180	0.0175	0.0170	0.0166	0.0162	0.0158	0.0155	0.0152	0.0149	0.0147	0.0145	0.0143	0.0141	0.0141
1.7	2.61	0.0250	0.0237	0.0223	0.0219	0.0214	0.0211	0.0207	0.0200	0.0194	0.0189	0.0184	0.0180	0.0176	0.0172	0.0169	0.0166	0.0163	0.0161	0.0159	0.0157	0.0157
1.8	2.76	0.0275	0.0262	0.0247	0.0242	0.0237	0.0233	0.0228	0.0221	0.0214	0.0209	0.0203	0.0199	0.0195	0.0191	0.0187	0.0184	0.0181	0.0178	0.0176	0.0173	0.0173
1.9	2.92	0.0302	0.0287	0.0271	0.0266	0.0260	0.0256	0.0251	0.0243	0.0236	0.0229	0.0224	0.0219	0.0214	0.0210	0.0206	0.0202	0.0199	0.0196	0.0193	0.0191	0.0191
2.0	3.07	0.0330	0.0314	0.0296	0.0290	0.0284	0.0279	0.0274	0.0266	0.0258	0.0251	0.0245	0.0239	0.0234	0.0230	0.0225	0.0222	0.0218	0.0215	0.0212	0.0209	0.0209
2.1	3.23	0.0359	0.0342	0.0322	0.0316	0.0310	0.0304	0.0299	0.0289	0.0281	0.0273	0.0267	0.0261	0.0255	0.0250	0.0246	0.0241	0.0238	0.0234	0.0231	0.0228	0.0228
2.2	3.38	0.0389	0.0370	0.0349	0.0343	0.0336	0.0330	0.0324	0.0314	0.0305	0.0297	0.0289	0.0283	0.0277	0.0272	0.0267	0.0262	0.0258	0.0254	0.0251	0.0247	0.0247
2.3	3.53	0.0420	0.0400	0.0377	0.0370	0.0363	0.0357	0.0350	0.0339	0.0329	0.0321	0.0313	0.0306	0.0300	0.0294	0.0289	0.0284	0.0279	0.0275	0.0271	0.0268	0.0268
2.4	3.69	0.0452	0.0430	0.0406	0.0399	0.0391	0.0384	0.0377	0.0365	0.0355	0.0346	0.0337	0.0330	0.0323	0.0317	0.0311	0.0306	0.0301	0.0297	0.0292	0.0289	0.0289
2.5	3.84	0.0485	0.0462	0.0436	0.0428	0.0419	0.0412	0.0405	0.0392	0.0381	0.0371	0.0362	0.0354	0.0347	0.0341	0.0334	0.0329	0.0324	0.0319	0.0314	0.0310	0.0310
2.6	3.99	0.0519	0.0495	0.0467	0.0458	0.0449	0.0442	0.0434	0.0420	0.0409	0.0398	0.0388	0.0380	0.0372	0.0365	0.0358	0.0353	0.0347	0.0342	0.0337	0.0333	0.0333
2.7	4.15	0.0554	0.0528	0.0499	0.0490	0.0480	0.0472	0.0464	0.0449	0.0437	0.0425	0.0415	0.0406	0.0398	0.0390	0.0383	0.0377	0.0371	0.0366	0.0361	0.0356	0.0356
2.8	4.30	0.0590	0.0562	0.0531	0.0522	0.0511	0.0503	0.0494	0.0479	0.0465	0.0453	0.0443	0.0433	0.0424	0.0416	0.0409	0.0402	0.0396	0.0390	0.0385	0.0380	0.0380
2.9	4.45	0.0627	0.0598	0.0565	0.0555	0.0544	0.0535	0.0525	0.0509	0.0495	0.0482	0.0471	0.0461	0.0451	0.0443	0.0435	0.0428	0.0421	0.0415	0.0410	0.0404	0.0404
3.0	4.61	0.0665	0.0634	0.0599	0.0588	0.0577	0.0567	0.0558	0.0541	0.0526	0.0512	0.0500	0.0489	0.0479	0.0470	0.0462	0.0455	0.0447	0.0441	0.0435	0.0430	0.0430
3.1	4.76	0.0704	0.0671	0.0635	0.0623	0.0611	0.0601	0.0591	0.0573	0.0557	0.0543	0.0530	0.0518	0.0508	0.0499	0.0490	0.0482	0.0474	0.0468	0.0461	0.0455	0.0455
3.2	4.91	0.0744	0.0710	0.0671	0.0659	0.0646	0.0635	0.0624	0.0606	0.0589	0.0574	0.0561	0.0548	0.0537	0.0527	0.0518	0.0510	0.0502	0.0495	0.0488	0.0482	0.0482
3.3	5.07	0.0784	0.0749	0.0708	0.0695	0.0682	0.0671	0.0659	0.0639	0.0622	0.0606	0.0592	0.0579	0.0568	0.0557	0.0547	0.0539	0.0530	0.0523	0.0516	0.0509	0.0509
3.4	5.22	0.0826	0.0789	0.0746	0.0733	0.0718	0.0707	0.0695	0.0674	0.0655	0.0639	0.0624	0.0611	0.0598	0.0587	0.0577	0.0568	0.0559	0.0551	0.0544	0.0537	0.0537
3.5	5.38	0.0869	0.0829	0.0785	0.0771	0.0756	0.0744	0.0731	0.0709	0.0690	0.0672	0.0657	0.0643	0.0630	0.0618	0.0608	0.0598	0.0589	0.0581	0.0573	0.0566	0.0566
3.6	5.53	0.0912	0.0871	0.0825	0.0810	0.0794	0.0782	0.0768	0.0745	0.0725	0.0707	0.0690	0.0676	0.0662	0.0650	0.0639	0.0629	0.0619	0.0611	0.0603	0.0595	0.0595
3.7	5.68	0.0957	0.0914	0.0865	0.0850	0.0833	0.0820	0.0806	0.0782	0.0761	0.0742	0.0725	0.0709	0.0695	0.0683	0.0671	0.0660	0.0650	0.0641	0.0633	0.0625	0.0625
3.8	5.84	0.1002	0.0958	0.0907	0.0890	0.0873	0.0859	0.0845	0.0820	0.0798	0.0778	0.0760	0.0744	0.0729	0.0716	0.0704	0.0693	0.0682	0.0672	0.0664	0.0655	0.0655

Continued on next page

Recommended Head Loss Design Range

Sizing in this region will lead to excessive head loss conditions.

Appendix E

MLC Hydronic Friction Loss Tables

3/4" Uponor MLC — 100% Water — Feet of Head per Foot of Tubing

Velocity (ft./sec.)	GPM	40°F 4°C	45°F 7°C	50°F 10°C	55°F 13°C	60°F 16°C	65°F 18°C	70°F 21°C	80°F 27°C	90°F 32°C	100°F 38°C	110°F 43°C	120°F 49°C	130°F 54°C	140°F 60°C	150°F 66°C	160°F 71°C	170°F 77°C	180°F 82°C	190°F 88°C	200°F 93°C
3.9	5.99	0.1049	0.1002	0.0949	0.0932	0.0914	0.0900	0.0884	0.0858	0.0835	0.0814	0.0796	0.0779	0.0764	0.0750	0.0737	0.0725	0.0714	0.0704	0.0695	0.0687
4.0	6.14	0.1096	0.1047	0.0992	0.0974	0.0956	0.0941	0.0925	0.0897	0.0873	0.0852	0.0832	0.0815	0.0799	0.0784	0.0771	0.0759	0.0747	0.0737	0.0727	0.0718
4.1	6.30	0.1144	0.1094	0.1036	0.1018	0.0998	0.0982	0.0966	0.0937	0.0912	0.0890	0.0870	0.0851	0.0835	0.0820	0.0806	0.0793	0.0781	0.0770	0.0760	0.0751
4.2	6.45	0.1194	0.1141	0.1081	0.1062	0.1042	0.1025	0.1008	0.0978	0.0952	0.0929	0.0908	0.0889	0.0871	0.0856	0.0841	0.0828	0.0816	0.0804	0.0794	0.0784
4.3	6.60	0.1244	0.1189	0.1126	0.1106	0.1086	0.1069	0.1051	0.1020	0.0993	0.0968	0.0946	0.0927	0.0909	0.0892	0.0877	0.0864	0.0851	0.0839	0.0828	0.0818
4.4	6.76	0.1294	0.1237	0.1173	0.1152	0.1130	0.1113	0.1094	0.1062	0.1034	0.1008	0.0986	0.0965	0.0947	0.0930	0.0914	0.0900	0.0886	0.0874	0.0863	0.0852
4.5	6.91	0.1346	0.1287	0.1220	0.1199	0.1176	0.1158	0.1138	0.1105	0.1076	0.1049	0.1026	0.1005	0.0985	0.0968	0.0951	0.0937	0.0923	0.0910	0.0898	0.0887
4.6	7.06	0.1399	0.1338	0.1268	0.1246	0.1223	0.1203	0.1183	0.1149	0.1119	0.1091	0.1067	0.1045	0.1025	0.1006	0.0990	0.0974	0.0960	0.0947	0.0934	0.0923
4.7	7.22	0.1453	0.1389	0.1317	0.1294	0.1270	0.1250	0.1229	0.1194	0.1162	0.1134	0.1108	0.1085	0.1065	0.1046	0.1028	0.1012	0.0997	0.0984	0.0971	0.0959
4.8	7.37	0.1507	0.1441	0.1367	0.1343	0.1318	0.1297	0.1276	0.1239	0.1206	0.1177	0.1151	0.1127	0.1105	0.1086	0.1068	0.1051	0.1036	0.1022	0.1009	0.0996
4.9	7.53	0.1562	0.1494	0.1417	0.1392	0.1367	0.1345	0.1323	0.1285	0.1251	0.1221	0.1194	0.1169	0.1147	0.1127	0.1108	0.1091	0.1075	0.1060	0.1047	0.1034
5.0	7.68	0.1619	0.1548	0.1468	0.1443	0.1416	0.1394	0.1371	0.1332	0.1297	0.1265	0.1237	0.1212	0.1189	0.1168	0.1149	0.1131	0.1114	0.1099	0.1085	0.1072
5.1	7.83	0.1676	0.1603	0.1520	0.1494	0.1467	0.1444	0.1420	0.1379	0.1343	0.1311	0.1282	0.1256	0.1232	0.1210	0.1190	0.1172	0.1155	0.1139	0.1125	0.1111
5.2	7.99	0.1734	0.1659	0.1573	0.1546	0.1518	0.1494	0.1470	0.1428	0.1390	0.1357	0.1327	0.1300	0.1275	0.1253	0.1232	0.1213	0.1195	0.1179	0.1165	0.1151
5.3	8.14	0.1792	0.1715	0.1627	0.1599	0.1570	0.1546	0.1520	0.1477	0.1438	0.1404	0.1373	0.1345	0.1319	0.1296	0.1275	0.1255	0.1237	0.1220	0.1205	0.1191
5.4	8.29	0.1852	0.1772	0.1682	0.1653	0.1623	0.1598	0.1571	0.1526	0.1487	0.1451	0.1419	0.1390	0.1364	0.1340	0.1318	0.1298	0.1279	0.1262	0.1246	0.1231
5.5	8.45	0.1913	0.1830	0.1737	0.1707	0.1676	0.1650	0.1623	0.1577	0.1536	0.1499	0.1466	0.1437	0.1410	0.1385	0.1362	0.1342	0.1322	0.1304	0.1288	0.1273
5.6	8.60	0.1974	0.1889	0.1793	0.1762	0.1730	0.1704	0.1676	0.1628	0.1586	0.1548	0.1514	0.1484	0.1456	0.1430	0.1407	0.1386	0.1365	0.1347	0.1330	0.1315
5.7	8.75	0.2036	0.1949	0.1850	0.1818	0.1785	0.1758	0.1729	0.1680	0.1637	0.1598	0.1563	0.1531	0.1503	0.1476	0.1452	0.1430	0.1410	0.1391	0.1373	0.1357
5.8	8.91	0.2099	0.2009	0.1907	0.1875	0.1841	0.1813	0.1784	0.1733	0.1688	0.1648	0.1612	0.1580	0.1550	0.1523	0.1498	0.1476	0.1454	0.1435	0.1417	0.1400
5.9	9.06	0.2163	0.2071	0.1966	0.1933	0.1898	0.1869	0.1838	0.1786	0.1740	0.1699	0.1662	0.1629	0.1598	0.1570	0.1545	0.1522	0.1500	0.1480	0.1461	0.1444
6.0	9.21	0.2228	0.2133	0.2025	0.1991	0.1955	0.1925	0.1894	0.1840	0.1793	0.1751	0.1713	0.1678	0.1647	0.1618	0.1592	0.1568	0.1546	0.1525	0.1506	0.1489
6.1	9.37	0.2293	0.2196	0.2085	0.2050	0.2013	0.1982	0.1950	0.1895	0.1847	0.1803	0.1764	0.1728	0.1696	0.1667	0.1640	0.1615	0.1592	0.1571	0.1552	0.1534
6.2	9.52	0.2360	0.2260	0.2146	0.2110	0.2072	0.2040	0.2007	0.1951	0.1901	0.1856	0.1816	0.1779	0.1746	0.1716	0.1689	0.1663	0.1639	0.1618	0.1598	0.1579
6.3	9.68	0.2427	0.2324	0.2207	0.2170	0.2131	0.2099	0.2065	0.2007	0.1956	0.1910	0.1869	0.1831	0.1797	0.1766	0.1738	0.1712	0.1687	0.1665	0.1645	0.1625

Recommended Head Loss Design Range

Sizing in this region will lead to excessive head loss conditions.

Appendix E

MLC Hydronic Friction Loss Tables

3/4" Uponor MLC — 30% Propylene Glycol — Feet of Head per Foot of Tubing

Velocity (ft./sec.)	GPM	40°F 4°C	45°F 7°C	50°F 10°C	55°F 13°C	60°F 16°C	65°F 18°C	70°F 21°C	80°F 27°C	90°F 32°C	100°F 38°C	110°F 43°C	120°F 49°C	130°F 54°C	140°F 60°C	150°F 66°C	160°F 71°C	170°F 77°C	180°F 82°C	190°F 88°C	200°F 93°C
0.5	0.77	0.0046	0.0044	0.0042	0.0040	0.0039	0.0037	0.0036	0.0034	0.0032	0.0030	0.0029	0.0027	0.0026	0.0025	0.0025	0.0024	0.0023	0.0023	0.0022	0.0022
0.6	0.92	0.0062	0.0059	0.0056	0.0054	0.0052	0.0050	0.0049	0.0046	0.0043	0.0041	0.0039	0.0037	0.0036	0.0035	0.0034	0.0033	0.0032	0.0031	0.0030	0.0030
0.7	1.08	0.0079	0.0076	0.0073	0.0070	0.0067	0.0065	0.0063	0.0059	0.0056	0.0053	0.0051	0.0049	0.0047	0.0045	0.0044	0.0043	0.0041	0.0040	0.0040	0.0039
0.8	1.23	0.0098	0.0095	0.0090	0.0087	0.0084	0.0081	0.0078	0.0074	0.0070	0.0066	0.0063	0.0061	0.0059	0.0057	0.0055	0.0054	0.0052	0.0051	0.0050	0.0049
0.9	1.38	0.0119	0.0115	0.0110	0.0106	0.0102	0.0099	0.0095	0.0090	0.0085	0.0081	0.0077	0.0074	0.0072	0.0069	0.0067	0.0066	0.0064	0.0062	0.0061	0.0060
1.0	1.54	0.0142	0.0137	0.0131	0.0126	0.0122	0.0118	0.0114	0.0107	0.0102	0.0097	0.0093	0.0089	0.0086	0.0083	0.0081	0.0079	0.0077	0.0075	0.0073	0.0072
1.1	1.69	0.0166	0.0160	0.0153	0.0148	0.0143	0.0138	0.0134	0.0126	0.0119	0.0114	0.0109	0.0105	0.0101	0.0098	0.0095	0.0093	0.0090	0.0088	0.0086	0.0085
1.2	1.84	0.0192	0.0185	0.0177	0.0171	0.0165	0.0160	0.0155	0.0146	0.0139	0.0132	0.0127	0.0122	0.0118	0.0114	0.0111	0.0108	0.0105	0.0103	0.0101	0.0099
1.3	2.00	0.0219	0.0211	0.0203	0.0196	0.0189	0.0183	0.0177	0.0167	0.0159	0.0151	0.0145	0.0140	0.0135	0.0131	0.0127	0.0124	0.0121	0.0118	0.0116	0.0114
1.4	2.15	0.0248	0.0239	0.0229	0.0222	0.0214	0.0208	0.0201	0.0190	0.0180	0.0172	0.0165	0.0159	0.0153	0.0149	0.0145	0.0141	0.0137	0.0134	0.0132	0.0129
1.5	2.30	0.0278	0.0268	0.0258	0.0249	0.0240	0.0233	0.0226	0.0213	0.0203	0.0194	0.0186	0.0179	0.0173	0.0167	0.0163	0.0159	0.0155	0.0152	0.0148	0.0146
1.6	2.46	0.0310	0.0299	0.0287	0.0278	0.0268	0.0260	0.0252	0.0238	0.0226	0.0216	0.0207	0.0200	0.0193	0.0187	0.0182	0.0178	0.0173	0.0170	0.0166	0.0163
1.7	2.61	0.0343	0.0331	0.0318	0.0308	0.0297	0.0288	0.0279	0.0264	0.0251	0.0240	0.0230	0.0222	0.0215	0.0208	0.0203	0.0197	0.0193	0.0189	0.0185	0.0182
1.8	2.76	0.0378	0.0364	0.0350	0.0339	0.0327	0.0318	0.0308	0.0291	0.0277	0.0265	0.0254	0.0245	0.0237	0.0230	0.0224	0.0218	0.0213	0.0208	0.0204	0.0201
1.9	2.92	0.0414	0.0399	0.0384	0.0372	0.0359	0.0348	0.0337	0.0319	0.0304	0.0291	0.0279	0.0269	0.0260	0.0252	0.0246	0.0240	0.0234	0.0229	0.0224	0.0221
2.0	3.07	0.0451	0.0435	0.0418	0.0405	0.0391	0.0380	0.0368	0.0349	0.0332	0.0318	0.0305	0.0294	0.0285	0.0276	0.0269	0.0262	0.0256	0.0251	0.0246	0.0242
2.1	3.23	0.0489	0.0472	0.0454	0.0440	0.0425	0.0413	0.0400	0.0379	0.0361	0.0346	0.0332	0.0320	0.0310	0.0301	0.0293	0.0286	0.0279	0.0273	0.0268	0.0263
2.2	3.38	0.0529	0.0511	0.0492	0.0476	0.0460	0.0447	0.0433	0.0411	0.0391	0.0374	0.0360	0.0347	0.0336	0.0326	0.0318	0.0310	0.0302	0.0296	0.0290	0.0286
2.3	3.53	0.0571	0.0551	0.0530	0.0514	0.0496	0.0482	0.0467	0.0443	0.0422	0.0404	0.0389	0.0375	0.0363	0.0352	0.0343	0.0335	0.0327	0.0320	0.0314	0.0309
2.4	3.69	0.0613	0.0592	0.0570	0.0552	0.0534	0.0519	0.0503	0.0477	0.0455	0.0435	0.0418	0.0404	0.0391	0.0379	0.0370	0.0361	0.0352	0.0345	0.0338	0.0333
2.5	3.84	0.0657	0.0635	0.0611	0.0592	0.0572	0.0556	0.0539	0.0512	0.0488	0.0467	0.0449	0.0434	0.0420	0.0408	0.0397	0.0388	0.0379	0.0371	0.0364	0.0358
2.6	3.99	0.0702	0.0678	0.0653	0.0633	0.0612	0.0595	0.0577	0.0547	0.0522	0.0500	0.0481	0.0464	0.0450	0.0436	0.0426	0.0415	0.0406	0.0398	0.0390	0.0384
2.7	4.15	0.0748	0.0723	0.0696	0.0675	0.0653	0.0635	0.0615	0.0584	0.0557	0.0534	0.0513	0.0496	0.0480	0.0466	0.0455	0.0444	0.0433	0.0425	0.0416	0.0410
2.8	4.30	0.0796	0.0769	0.0741	0.0718	0.0695	0.0676	0.0655	0.0622	0.0593	0.0569	0.0547	0.0529	0.0512	0.0497	0.0485	0.0473	0.0462	0.0453	0.0444	0.0437
2.9	4.45	0.0845	0.0816	0.0786	0.0763	0.0738	0.0718	0.0696	0.0661	0.0631	0.0604	0.0581	0.0562	0.0544	0.0528	0.0516	0.0503	0.0492	0.0482	0.0472	0.0465
3.0	4.61	0.0895	0.0865	0.0833	0.0808	0.0782	0.0761	0.0738	0.0701	0.0669	0.0641	0.0617	0.0596	0.0578	0.0561	0.0547	0.0534	0.0522	0.0512	0.0502	0.0494
3.1	4.76	0.0946	0.0915	0.0881	0.0855	0.0827	0.0805	0.0781	0.0742	0.0708	0.0679	0.0653	0.0631	0.0612	0.0594	0.0580	0.0566	0.0553	0.0542	0.0531	0.0524
3.2	4.91	0.0998	0.0965	0.0930	0.0903	0.0873	0.0850	0.0825	0.0783	0.0748	0.0717	0.0690	0.0667	0.0647	0.0628	0.0613	0.0598	0.0585	0.0573	0.0562	0.0554
3.3	5.07	0.1052	0.1017	0.0980	0.0952	0.0921	0.0896	0.0869	0.0826	0.0789	0.0757	0.0728	0.0704	0.0683	0.0663	0.0647	0.0632	0.0617	0.0605	0.0594	0.0585
3.4	5.22	0.1107	0.1071	0.1032	0.1002	0.0969	0.0943	0.0915	0.0870	0.0831	0.0797	0.0767	0.0742	0.0719	0.0699	0.0682	0.0666	0.0651	0.0638	0.0626	0.0617
3.5	5.38	0.1163	0.1125	0.1084	0.1053	0.1019	0.0992	0.0962	0.0915	0.0874	0.0838	0.0807	0.0781	0.0757	0.0735	0.0718	0.0701	0.0685	0.0672	0.0659	0.0649
3.6	5.53	0.1220	0.1180	0.1138	0.1105	0.1069	0.1041	0.1010	0.0961	0.0918	0.0881	0.0848	0.0820	0.0795	0.0773	0.0754	0.0736	0.0720	0.0706	0.0692	0.0682
3.7	5.68	0.1278	0.1237	0.1193	0.1158	0.1121	0.1091	0.1059	0.1007	0.0963	0.0924	0.0890	0.0861	0.0834	0.0811	0.0792	0.0773	0.0756	0.0741	0.0727	0.0716
3.8	5.84	0.1338	0.1295	0.1248	0.1212	0.1174	0.1143	0.1109	0.1055	0.1008	0.0968	0.0932	0.0902	0.0875	0.0850	0.0830	0.0810	0.0792	0.0777	0.0762	0.0751

Continued on next page

Recommended Head Loss Design Range

Sizing in this region will lead to excessive head loss conditions.

Appendix E

MLC Hydronic Friction Loss Tables

3/4" Uponor MLC — 30% Propylene Glycol — Feet of Head per Foot of Tubing

Velocity (ft./sec.)	GPM	40°F 4°C	45°F 7°C	50°F 10°C	55°F 13°C	60°F 16°C	65°F 18°C	70°F 21°C	80°F 27°C	90°F 32°C	100°F 38°C	110°F 43°C	120°F 49°C	130°F 54°C	140°F 60°C	150°F 66°C	160°F 71°C	170°F 77°C	180°F 82°C	190°F 88°C	200°F 93°C
3.9	5.99	0.1398	0.1353	0.1305	0.1268	0.1228	0.1195	0.1160	0.1104	0.1055	0.1013	0.0975	0.0944	0.0915	0.0889	0.0869	0.0848	0.0829	0.0814	0.0798	0.0787
4.0	6.14	0.1460	0.1413	0.1363	0.1324	0.1282	0.1248	0.1212	0.1153	0.1103	0.1058	0.1020	0.0987	0.0957	0.0930	0.0908	0.0887	0.0867	0.0851	0.0835	0.0823
4.1	6.30	0.1523	0.1474	0.1422	0.1382	0.1338	0.1303	0.1265	0.1204	0.1151	0.1105	0.1065	0.1030	0.1000	0.0971	0.0949	0.0927	0.0906	0.0889	0.0872	0.0860
4.2	6.45	0.1587	0.1537	0.1482	0.1440	0.1395	0.1358	0.1319	0.1255	0.1200	0.1153	0.1111	0.1075	0.1043	0.1014	0.0990	0.0967	0.0946	0.0928	0.0910	0.0897
4.3	6.60	0.1652	0.1600	0.1544	0.1500	0.1453	0.1415	0.1374	0.1308	0.1251	0.1201	0.1158	0.1120	0.1087	0.1056	0.1032	0.1008	0.0986	0.0967	0.0949	0.0936
4.4	6.76	0.1719	0.1664	0.1606	0.1560	0.1512	0.1472	0.1430	0.1361	0.1302	0.1250	0.1205	0.1167	0.1132	0.1100	0.1075	0.1050	0.1027	0.1008	0.0989	0.0975
4.5	6.91	0.1786	0.1730	0.1669	0.1622	0.1572	0.1531	0.1487	0.1416	0.1354	0.1301	0.1254	0.1214	0.1178	0.1145	0.1118	0.1092	0.1069	0.1049	0.1029	0.1014
4.6	7.06	0.1855	0.1796	0.1734	0.1685	0.1632	0.1590	0.1545	0.1471	0.1407	0.1352	0.1303	0.1261	0.1224	0.1190	0.1163	0.1136	0.1111	0.1090	0.1070	0.1055
4.7	7.22	0.1924	0.1864	0.1799	0.1748	0.1694	0.1650	0.1603	0.1527	0.1461	0.1403	0.1353	0.1310	0.1271	0.1236	0.1208	0.1180	0.1154	0.1133	0.1112	0.1096
4.8	7.37	0.1995	0.1933	0.1865	0.1813	0.1757	0.1712	0.1663	0.1584	0.1516	0.1456	0.1404	0.1360	0.1319	0.1283	0.1254	0.1225	0.1198	0.1176	0.1154	0.1138
4.9	7.53	0.2067	0.2002	0.1933	0.1879	0.1821	0.1774	0.1724	0.1642	0.1571	0.1510	0.1456	0.1410	0.1368	0.1331	0.1300	0.1270	0.1243	0.1220	0.1197	0.1180
5.0	7.68	0.2140	0.2073	0.2001	0.1946	0.1886	0.1837	0.1785	0.1701	0.1628	0.1564	0.1508	0.1461	0.1418	0.1379	0.1347	0.1317	0.1288	0.1264	0.1241	0.1224
5.1	7.83	0.2214	0.2145	0.2071	0.2013	0.1952	0.1901	0.1848	0.1761	0.1685	0.1620	0.1562	0.1513	0.1468	0.1428	0.1396	0.1364	0.1334	0.1310	0.1285	0.1267
5.2	7.99	0.2289	0.2218	0.2142	0.2082	0.2018	0.1967	0.1911	0.1821	0.1743	0.1676	0.1616	0.1565	0.1520	0.1478	0.1444	0.1412	0.1381	0.1356	0.1331	0.1312
5.3	8.14	0.2365	0.2292	0.2213	0.2152	0.2086	0.2033	0.1976	0.1883	0.1802	0.1733	0.1671	0.1619	0.1572	0.1529	0.1494	0.1460	0.1429	0.1403	0.1377	0.1357
5.4	8.29	0.2442	0.2367	0.2286	0.2223	0.2155	0.2100	0.2041	0.1945	0.1862	0.1790	0.1727	0.1673	0.1624	0.1580	0.1544	0.1509	0.1477	0.1450	0.1423	0.1403
5.5	8.45	0.2520	0.2443	0.2359	0.2294	0.2225	0.2168	0.2107	0.2009	0.1923	0.1849	0.1784	0.1728	0.1678	0.1632	0.1595	0.1559	0.1526	0.1498	0.1471	0.1450
5.6	8.60	0.2600	0.2520	0.2434	0.2367	0.2295	0.2237	0.2175	0.2073	0.1985	0.1909	0.1841	0.1784	0.1732	0.1685	0.1647	0.1610	0.1576	0.1547	0.1519	0.1498
5.7	8.75	0.2680	0.2598	0.2510	0.2441	0.2367	0.2307	0.2243	0.2138	0.2047	0.1969	0.1900	0.1841	0.1787	0.1739	0.1700	0.1661	0.1626	0.1596	0.1567	0.1546
5.8	8.91	0.2762	0.2677	0.2586	0.2515	0.2439	0.2378	0.2312	0.2204	0.2111	0.2030	0.1959	0.1898	0.1843	0.1793	0.1753	0.1714	0.1677	0.1647	0.1617	0.1594
5.9	9.06	0.2844	0.2757	0.2664	0.2591	0.2513	0.2449	0.2382	0.2271	0.2175	0.2092	0.2019	0.1956	0.1900	0.1848	0.1807	0.1766	0.1729	0.1698	0.1667	0.1644

Appendix E

MLC Hydronic Friction Loss Tables

3/4" Uponor MLC — 40% Propylene Glycol — Feet of Head per Foot of Tubing

Velocity (ft./sec.)	GPM	40°F 4°C	45°F 7°C	50°F 10°C	55°F 13°C	60°F 16°C	65°F 18°C	70°F 21°C	80°F 27°C	90°F 32°C	100°F 38°C	110°F 43°C	120°F 49°C	130°F 54°C	140°F 60°C	150°F 66°C	160°F 71°C	170°F 77°C	180°F 82°C	190°F 88°C	200°F 93°C	
0.5	0.77	0.0056	0.0053	0.0050	0.0048	0.0045	0.0043	0.0041	0.0038	0.0036	0.0033	0.0032	0.0030	0.0029	0.0028	0.0027	0.0026	0.0025	0.0025	0.0026	0.0025	0.0025
0.6	0.92	0.0075	0.0071	0.0067	0.0064	0.0061	0.0058	0.0056	0.0052	0.0048	0.0045	0.0043	0.0041	0.0039	0.0037	0.0036	0.0035	0.0034	0.0034	0.0035	0.0034	0.0033
0.7	1.08	0.0096	0.0091	0.0086	0.0082	0.0078	0.0075	0.0072	0.0067	0.0062	0.0059	0.0056	0.0053	0.0051	0.0049	0.0047	0.0046	0.0044	0.0044	0.0046	0.0045	0.0044
0.8	1.23	0.0119	0.0113	0.0107	0.0102	0.0097	0.0093	0.0089	0.0083	0.0078	0.0073	0.0070	0.0066	0.0064	0.0061	0.0059	0.0057	0.0055	0.0055	0.0058	0.0056	0.0055
0.9	1.38	0.0144	0.0137	0.0129	0.0124	0.0118	0.0113	0.0109	0.0101	0.0095	0.0089	0.0085	0.0081	0.0078	0.0075	0.0072	0.0070	0.0068	0.0067	0.0071	0.0069	0.0067
1.0	1.54	0.0171	0.0162	0.0154	0.0147	0.0140	0.0135	0.0129	0.0120	0.0113	0.0107	0.0101	0.0097	0.0093	0.0089	0.0086	0.0084	0.0081	0.0083	0.0085	0.0083	0.0080
1.1	1.69	0.0199	0.0190	0.0180	0.0172	0.0164	0.0158	0.0152	0.0141	0.0133	0.0125	0.0119	0.0114	0.0109	0.0105	0.0102	0.0099	0.0096	0.0100	0.0097	0.0097	0.0095
1.2	1.84	0.0230	0.0219	0.0207	0.0199	0.0190	0.0183	0.0175	0.0163	0.0154	0.0145	0.0138	0.0132	0.0127	0.0122	0.0118	0.0115	0.0112	0.0116	0.0113	0.0113	0.0110
1.3	2.00	0.0262	0.0250	0.0237	0.0227	0.0217	0.0209	0.0200	0.0187	0.0176	0.0167	0.0159	0.0151	0.0146	0.0140	0.0136	0.0132	0.0128	0.0133	0.0130	0.0130	0.0127
1.4	2.15	0.0296	0.0282	0.0268	0.0257	0.0245	0.0236	0.0227	0.0212	0.0199	0.0189	0.0180	0.0172	0.0165	0.0159	0.0154	0.0146	0.0146	0.0151	0.0148	0.0148	0.0144
1.5	2.30	0.0331	0.0316	0.0300	0.0288	0.0275	0.0265	0.0255	0.0238	0.0224	0.0212	0.0202	0.0194	0.0186	0.0179	0.0174	0.0169	0.0164	0.0170	0.0166	0.0166	0.0162
1.6	2.46	0.0368	0.0352	0.0334	0.0321	0.0306	0.0296	0.0284	0.0266	0.0250	0.0237	0.0226	0.0216	0.0208	0.0201	0.0194	0.0189	0.0184	0.0191	0.0186	0.0186	0.0182
1.7	2.61	0.0407	0.0389	0.0369	0.0355	0.0339	0.0327	0.0315	0.0294	0.0277	0.0263	0.0251	0.0240	0.0231	0.0223	0.0216	0.0210	0.0204	0.0212	0.0207	0.0207	0.0202
1.8	2.76	0.0447	0.0427	0.0406	0.0390	0.0373	0.0360	0.0346	0.0324	0.0306	0.0290	0.0277	0.0265	0.0255	0.0246	0.0238	0.0232	0.0225	0.0234	0.0228	0.0228	0.0223
1.9	2.92	0.0489	0.0468	0.0444	0.0427	0.0409	0.0395	0.0380	0.0355	0.0335	0.0318	0.0304	0.0291	0.0280	0.0270	0.0262	0.0255	0.0248	0.0257	0.0251	0.0251	0.0245
2.0	3.07	0.0532	0.0509	0.0484	0.0466	0.0446	0.0430	0.0414	0.0388	0.0366	0.0347	0.0332	0.0318	0.0306	0.0295	0.0286	0.0279	0.0271	0.0281	0.0274	0.0274	0.0268
2.1	3.23	0.0577	0.0552	0.0525	0.0505	0.0484	0.0467	0.0450	0.0421	0.0398	0.0378	0.0361	0.0345	0.0333	0.0321	0.0312	0.0303	0.0295	0.0306	0.0299	0.0299	0.0292
2.2	3.38	0.0624	0.0597	0.0568	0.0546	0.0523	0.0506	0.0487	0.0456	0.0431	0.0409	0.0391	0.0374	0.0361	0.0348	0.0338	0.0329	0.0320	0.0332	0.0324	0.0324	0.0316
2.3	3.53	0.0672	0.0643	0.0612	0.0589	0.0564	0.0545	0.0525	0.0492	0.0465	0.0442	0.0422	0.0404	0.0389	0.0376	0.0365	0.0355	0.0346	0.0358	0.0350	0.0350	0.0342
2.4	3.69	0.0721	0.0690	0.0657	0.0633	0.0606	0.0586	0.0564	0.0529	0.0500	0.0475	0.0454	0.0435	0.0419	0.0405	0.0393	0.0383	0.0372	0.0386	0.0377	0.0377	0.0368
2.5	3.84	0.0772	0.0739	0.0704	0.0678	0.0649	0.0628	0.0605	0.0567	0.0536	0.0510	0.0487	0.0467	0.0450	0.0435	0.0422	0.0411	0.0400	0.0414	0.0405	0.0405	0.0396
2.6	3.99	0.0824	0.0789	0.0752	0.0724	0.0694	0.0671	0.0646	0.0607	0.0573	0.0545	0.0521	0.0500	0.0482	0.0466	0.0452	0.0440	0.0428	0.0444	0.0434	0.0434	0.0424
2.7	4.15	0.0878	0.0841	0.0801	0.0772	0.0740	0.0715	0.0689	0.0647	0.0612	0.0582	0.0556	0.0534	0.0515	0.0497	0.0483	0.0470	0.0458	0.0474	0.0463	0.0463	0.0453
2.8	4.30	0.0933	0.0894	0.0852	0.0821	0.0787	0.0761	0.0733	0.0689	0.0651	0.0620	0.0593	0.0569	0.0548	0.0530	0.0515	0.0501	0.0488	0.0505	0.0494	0.0494	0.0483
2.9	4.45	0.0989	0.0948	0.0904	0.0871	0.0835	0.0808	0.0779	0.0731	0.0692	0.0658	0.0630	0.0604	0.0583	0.0563	0.0547	0.0533	0.0519	0.0537	0.0525	0.0525	0.0513
3.0	4.61	0.1047	0.1004	0.0957	0.0922	0.0885	0.0856	0.0825	0.0775	0.0733	0.0698	0.0668	0.0641	0.0618	0.0598	0.0581	0.0566	0.0551	0.0570	0.0557	0.0557	0.0545
3.1	4.76	0.1106	0.1061	0.1012	0.0975	0.0935	0.0905	0.0872	0.0820	0.0776	0.0739	0.0707	0.0679	0.0655	0.0633	0.0615	0.0599	0.0583	0.0604	0.0590	0.0590	0.0577
3.2	4.91	0.1167	0.1119	0.1067	0.1029	0.0987	0.0955	0.0921	0.0866	0.0820	0.0781	0.0747	0.0717	0.0692	0.0669	0.0650	0.0633	0.0617	0.0638	0.0624	0.0624	0.0610
3.3	5.07	0.1229	0.1179	0.1124	0.1084	0.1040	0.1007	0.0971	0.0913	0.0864	0.0823	0.0788	0.0757	0.0730	0.0706	0.0686	0.0669	0.0651	0.0674	0.0659	0.0659	0.0644
3.4	5.22	0.1292	0.1240	0.1183	0.1140	0.1094	0.1059	0.1022	0.0961	0.0910	0.0867	0.0830	0.0797	0.0769	0.0744	0.0723	0.0705	0.0686	0.0710	0.0694	0.0694	0.0679
3.5	5.38	0.1357	0.1302	0.1242	0.1198	0.1150	0.1113	0.1074	0.1010	0.0957	0.0912	0.0873	0.0838	0.0809	0.0783	0.0761	0.0741	0.0722	0.0747	0.0731	0.0731	0.0715
3.6	5.53	0.1423	0.1365	0.1303	0.1257	0.1207	0.1168	0.1127	0.1061	0.1004	0.0957	0.0917	0.0881	0.0850	0.0822	0.0799	0.0779	0.0759	0.0785	0.0768	0.0768	0.0751
3.7	5.68	0.1490	0.1430	0.1365	0.1317	0.1264	0.1224	0.1181	0.1112	0.1053	0.1004	0.0961	0.0924	0.0892	0.0863	0.0838	0.0817	0.0796	0.0824	0.0806	0.0806	0.0788
3.8	5.84	0.1558	0.1496	0.1428	0.1378	0.1323	0.1281	0.1236	0.1164	0.1103	0.1051	0.1007	0.0968	0.0934	0.0904	0.0879	0.0857	0.0835	0.0863	0.0845	0.0845	0.0826

Continued on next page

Recommended Head Loss Design Range

Sizing in this region will lead to excessive head loss conditions.

Appendix E

MLC Hydronic Friction Loss Tables

3/4" Uponor MLC — 40% Propylene Glycol — Feet of Head per Foot of Tubing

Velocity (ft./sec.)	GPM	40°F 4°C	45°F 7°C	50°F 10°C	55°F 13°C	60°F 16°C	65°F 18°C	70°F 21°C	80°F 27°C	90°F 32°C	100°F 38°C	110°F 43°C	120°F 49°C	130°F 54°C	140°F 60°C	150°F 66°C	160°F 71°C	170°F 77°C	180°F 82°C	190°F 88°C	200°F 93°C
3.9	5.99	0.1628	0.1563	0.1493	0.1440	0.1383	0.1340	0.1293	0.1217	0.1154	0.1100	0.1054	0.1013	0.0978	0.0946	0.0920	0.0897	0.0874	0.0904	0.0884	0.0865
4.0	6.14	0.1699	0.1632	0.1558	0.1504	0.1444	0.1399	0.1350	0.1272	0.1205	0.1149	0.1101	0.1058	0.1022	0.0989	0.0962	0.0938	0.0914	0.0945	0.0924	0.0904
4.1	6.30	0.1772	0.1701	0.1625	0.1568	0.1507	0.1460	0.1409	0.1327	0.1258	0.1200	0.1150	0.1105	0.1067	0.1033	0.1004	0.0979	0.0954	0.0987	0.0966	0.0945
4.2	6.45	0.1845	0.1772	0.1693	0.1634	0.1570	0.1521	0.1468	0.1383	0.1312	0.1251	0.1199	0.1153	0.1113	0.1078	0.1048	0.1022	0.0996	0.1030	0.1007	0.0986
4.3	6.60	0.1920	0.1845	0.1762	0.1701	0.1635	0.1584	0.1529	0.1441	0.1366	0.1303	0.1249	0.1201	0.1160	0.1123	0.1092	0.1065	0.1038	0.1073	0.1050	0.1027
4.4	6.76	0.1997	0.1918	0.1833	0.1769	0.1700	0.1648	0.1591	0.1499	0.1422	0.1357	0.1300	0.1250	0.1208	0.1170	0.1137	0.1109	0.1081	0.1118	0.1094	0.1070
4.5	6.91	0.2074	0.1993	0.1904	0.1838	0.1767	0.1712	0.1654	0.1559	0.1478	0.1411	0.1352	0.1301	0.1256	0.1217	0.1183	0.1154	0.1125	0.1163	0.1138	0.1113
4.6	7.06	0.2153	0.2068	0.1977	0.1909	0.1835	0.1778	0.1717	0.1619	0.1536	0.1466	0.1405	0.1352	0.1306	0.1265	0.1230	0.1200	0.1169	0.1209	0.1183	0.1158
4.7	7.22	0.2233	0.2146	0.2051	0.1980	0.1904	0.1845	0.1782	0.1680	0.1594	0.1522	0.1459	0.1403	0.1356	0.1313	0.1277	0.1246	0.1215	0.1256	0.1229	0.1202
4.8	7.37	0.2314	0.2224	0.2126	0.2053	0.1974	0.1913	0.1848	0.1743	0.1654	0.1579	0.1514	0.1456	0.1407	0.1363	0.1326	0.1293	0.1261	0.1303	0.1275	0.1248
4.9	7.53	0.2396	0.2303	0.2202	0.2127	0.2045	0.1982	0.1915	0.1806	0.1714	0.1636	0.1569	0.1510	0.1459	0.1413	0.1375	0.1341	0.1308	0.1351	0.1323	0.1295
5.0	7.68	0.2480	0.2384	0.2279	0.2201	0.2117	0.2053	0.1983	0.1871	0.1775	0.1695	0.1626	0.1564	0.1512	0.1464	0.1425	0.1390	0.1355	0.1401	0.1371	0.1342
5.1	7.83	0.2565	0.2466	0.2358	0.2277	0.2191	0.2124	0.2052	0.1936	0.1838	0.1755	0.1683	0.1619	0.1565	0.1516	0.1475	0.1440	0.1404	0.1450	0.1420	0.1390
5.2	7.99	0.2651	0.2548	0.2437	0.2355	0.2265	0.2196	0.2122	0.2002	0.1901	0.1815	0.1741	0.1676	0.1620	0.1569	0.1527	0.1490	0.1453	0.1501	0.1469	0.1438
5.3	8.14	0.2738	0.2633	0.2518	0.2433	0.2340	0.2269	0.2193	0.2069	0.1965	0.1877	0.1800	0.1733	0.1675	0.1623	0.1579	0.1541	0.1503	0.1552	0.1520	0.1488
5.4	8.29	0.2826	0.2718	0.2600	0.2512	0.2417	0.2344	0.2265	0.2138	0.2030	0.1939	0.1860	0.1790	0.1731	0.1677	0.1632	0.1593	0.1553	0.1605	0.1571	0.1538
5.5	8.45	0.2916	0.2804	0.2683	0.2592	0.2494	0.2419	0.2338	0.2207	0.2096	0.2002	0.1921	0.1849	0.1788	0.1732	0.1686	0.1645	0.1605	0.1657	0.1623	0.1589
5.6	8.60	0.3007	0.2892	0.2767	0.2674	0.2573	0.2495	0.2412	0.2277	0.2162	0.2066	0.1983	0.1908	0.1845	0.1788	0.1740	0.1698	0.1657	0.1711	0.1675	0.1640

Sizing in this region will lead to excessive head loss conditions.

Recommended Head Loss Design Range

Appendix E

MLC Hydronic Friction Loss Tables

3/4" Uponor MLC — 50% Propylene Glycol — Feet of Head per Foot of Tubing

Velocity (ft./sec.)	GPM	40°F 4°C	45°F 7°C	50°F 10°C	55°F 13°C	60°F 16°C	65°F 18°C	70°F 21°C	80°F 27°C	90°F 32°C	100°F 38°C	110°F 43°C	120°F 49°C	130°F 54°C	140°F 60°C	150°F 66°C	160°F 71°C	170°F 77°C	180°F 82°C	190°F 88°C	200°F 93°C
0.5	0.77	0.0066	0.0062	0.0058	0.0055	0.0052	0.0050	0.0047	0.0043	0.0040	0.0037	0.0035	0.0033	0.0032	0.0030	0.0029	0.0028	0.0027	0.0026	0.0025	0.0025
0.6	0.92	0.0088	0.0083	0.0078	0.0074	0.0070	0.0067	0.0064	0.0058	0.0054	0.0051	0.0048	0.0045	0.0043	0.0041	0.0039	0.0038	0.0037	0.0035	0.0034	0.0033
0.7	1.08	0.0112	0.0106	0.0100	0.0095	0.0090	0.0086	0.0082	0.0075	0.0070	0.0065	0.0062	0.0058	0.0056	0.0053	0.0051	0.0049	0.0048	0.0046	0.0045	0.0044
0.8	1.23	0.0139	0.0131	0.0123	0.0118	0.0111	0.0107	0.0102	0.0094	0.0087	0.0082	0.0077	0.0073	0.0070	0.0067	0.0064	0.0062	0.0060	0.0058	0.0056	0.0055
0.9	1.38	0.0167	0.0159	0.0149	0.0142	0.0135	0.0129	0.0123	0.0114	0.0106	0.0099	0.0094	0.0089	0.0085	0.0081	0.0078	0.0075	0.0073	0.0071	0.0069	0.0067
1.0	1.54	0.0198	0.0188	0.0177	0.0169	0.0160	0.0153	0.0146	0.0135	0.0126	0.0118	0.0112	0.0106	0.0101	0.0097	0.0094	0.0090	0.0087	0.0085	0.0083	0.0080
1.1	1.69	0.0231	0.0219	0.0206	0.0197	0.0187	0.0179	0.0171	0.0159	0.0148	0.0139	0.0131	0.0125	0.0119	0.0114	0.0110	0.0106	0.0103	0.0100	0.0097	0.0095
1.2	1.84	0.0266	0.0252	0.0238	0.0227	0.0216	0.0207	0.0198	0.0183	0.0171	0.0161	0.0152	0.0145	0.0138	0.0133	0.0128	0.0123	0.0119	0.0116	0.0113	0.0110
1.3	2.00	0.0302	0.0287	0.0271	0.0259	0.0246	0.0236	0.0226	0.0209	0.0196	0.0184	0.0174	0.0166	0.0158	0.0152	0.0146	0.0142	0.0137	0.0133	0.0130	0.0127
1.4	2.15	0.0341	0.0324	0.0306	0.0292	0.0278	0.0267	0.0255	0.0237	0.0221	0.0208	0.0197	0.0188	0.0180	0.0173	0.0166	0.0161	0.0156	0.0151	0.0148	0.0144
1.5	2.30	0.0381	0.0362	0.0342	0.0328	0.0312	0.0299	0.0287	0.0266	0.0249	0.0234	0.0222	0.0211	0.0202	0.0194	0.0187	0.0181	0.0176	0.0170	0.0166	0.0162
1.6	2.46	0.0423	0.0403	0.0381	0.0364	0.0347	0.0333	0.0319	0.0296	0.0277	0.0261	0.0248	0.0236	0.0226	0.0217	0.0209	0.0203	0.0196	0.0191	0.0186	0.0182
1.7	2.61	0.0467	0.0445	0.0421	0.0403	0.0383	0.0369	0.0353	0.0328	0.0307	0.0290	0.0275	0.0262	0.0251	0.0241	0.0232	0.0225	0.0218	0.0212	0.0207	0.0202
1.8	2.76	0.0513	0.0488	0.0462	0.0443	0.0422	0.0406	0.0388	0.0361	0.0338	0.0319	0.0303	0.0289	0.0276	0.0266	0.0256	0.0248	0.0241	0.0234	0.0228	0.0223
1.9	2.92	0.0560	0.0534	0.0505	0.0484	0.0461	0.0444	0.0425	0.0396	0.0371	0.0350	0.0332	0.0317	0.0303	0.0292	0.0281	0.0273	0.0264	0.0257	0.0251	0.0245
2.0	3.07	0.0609	0.0581	0.0550	0.0527	0.0502	0.0484	0.0463	0.0431	0.0404	0.0382	0.0362	0.0346	0.0331	0.0319	0.0308	0.0298	0.0289	0.0281	0.0274	0.0268
2.1	3.23	0.0660	0.0629	0.0596	0.0571	0.0545	0.0525	0.0503	0.0468	0.0439	0.0415	0.0394	0.0376	0.0360	0.0347	0.0335	0.0324	0.0314	0.0306	0.0299	0.0292
2.2	3.38	0.0712	0.0680	0.0644	0.0617	0.0589	0.0567	0.0544	0.0507	0.0475	0.0449	0.0427	0.0407	0.0390	0.0376	0.0363	0.0351	0.0341	0.0332	0.0324	0.0316
2.3	3.53	0.0767	0.0731	0.0693	0.0665	0.0634	0.0611	0.0586	0.0546	0.0513	0.0484	0.0460	0.0440	0.0422	0.0406	0.0392	0.0380	0.0368	0.0358	0.0350	0.0342
2.4	3.69	0.0822	0.0785	0.0744	0.0714	0.0681	0.0656	0.0630	0.0587	0.0551	0.0521	0.0495	0.0473	0.0454	0.0437	0.0422	0.0409	0.0397	0.0386	0.0377	0.0368
2.5	3.84	0.0879	0.0840	0.0796	0.0764	0.0729	0.0703	0.0675	0.0629	0.0591	0.0559	0.0531	0.0507	0.0487	0.0469	0.0453	0.0439	0.0426	0.0414	0.0405	0.0396
2.6	3.99	0.0938	0.0896	0.0850	0.0816	0.0779	0.0751	0.0721	0.0672	0.0632	0.0598	0.0568	0.0543	0.0521	0.0502	0.0485	0.0470	0.0456	0.0444	0.0434	0.0424
2.7	4.15	0.0999	0.0954	0.0905	0.0869	0.0830	0.0800	0.0768	0.0717	0.0674	0.0637	0.0606	0.0580	0.0556	0.0536	0.0518	0.0502	0.0487	0.0474	0.0463	0.0453
2.8	4.30	0.1061	0.1013	0.0962	0.0924	0.0882	0.0851	0.0817	0.0763	0.0717	0.0678	0.0646	0.0617	0.0592	0.0570	0.0551	0.0535	0.0519	0.0505	0.0494	0.0483
2.9	4.45	0.1124	0.1074	0.1020	0.0980	0.0936	0.0903	0.0867	0.0810	0.0761	0.0721	0.0686	0.0656	0.0629	0.0606	0.0586	0.0568	0.0552	0.0537	0.0525	0.0513
3.0	4.61	0.1189	0.1137	0.1080	0.1037	0.0991	0.0956	0.0918	0.0858	0.0807	0.0764	0.0727	0.0695	0.0667	0.0643	0.0622	0.0603	0.0586	0.0570	0.0557	0.0545
3.1	4.76	0.1256	0.1200	0.1141	0.1096	0.1047	0.1010	0.0971	0.0907	0.0853	0.0808	0.0769	0.0736	0.0707	0.0681	0.0658	0.0639	0.0620	0.0604	0.0590	0.0577
3.2	4.91	0.1324	0.1266	0.1203	0.1156	0.1105	0.1066	0.1024	0.0957	0.0901	0.0853	0.0813	0.0777	0.0747	0.0719	0.0696	0.0675	0.0656	0.0638	0.0624	0.0610
3.3	5.07	0.1393	0.1332	0.1266	0.1217	0.1164	0.1123	0.1079	0.1009	0.0950	0.0900	0.0857	0.0820	0.0788	0.0759	0.0734	0.0712	0.0692	0.0674	0.0659	0.0644
3.4	5.22	0.1464	0.1401	0.1332	0.1280	0.1224	0.1181	0.1135	0.1062	0.1000	0.0947	0.0902	0.0863	0.0829	0.0800	0.0773	0.0751	0.0729	0.0710	0.0694	0.0679
3.5	5.38	0.1537	0.1470	0.1398	0.1344	0.1285	0.1241	0.1193	0.1116	0.1051	0.0996	0.0949	0.0908	0.0872	0.0841	0.0814	0.0790	0.0767	0.0747	0.0731	0.0715
3.6	5.53	0.1611	0.1541	0.1466	0.1409	0.1348	0.1301	0.1251	0.1171	0.1103	0.1045	0.0996	0.0953	0.0916	0.0883	0.0855	0.0830	0.0806	0.0785	0.0768	0.0751
3.7	5.68	0.1686	0.1614	0.1535	0.1476	0.1412	0.1363	0.1311	0.1227	0.1156	0.1096	0.1044	0.1000	0.0961	0.0927	0.0897	0.0870	0.0846	0.0824	0.0806	0.0788
3.8	5.84	0.1763	0.1687	0.1605	0.1544	0.1477	0.1426	0.1372	0.1284	0.1210	0.1147	0.1094	0.1047	0.1007	0.0971	0.0939	0.0912	0.0886	0.0863	0.0845	0.0826

Continued on next page

Recommended Head Loss Design Range Sizing in this region will lead to excessive head loss conditions.

Appendix E

MLC Hydronic Friction Loss Tables

3/4" Uponor MLC — 50% Propylene Glycol — Feet of Head per Foot of Tubing

Velocity (ft./sec.)	GPM	40°F 4°C	45°F 7°C	50°F 10°C	55°F 13°C	60°F 16°C	65°F 18°C	70°F 21°C	80°F 27°C	90°F 32°C	100°F 38°C	110°F 43°C	120°F 49°C	130°F 54°C	140°F 60°C	150°F 66°C	160°F 71°C	170°F 77°C	180°F 82°C	190°F 88°C	200°F 93°C
3.9	5.99	0.1841	0.1762	0.1677	0.1613	0.1544	0.1491	0.1434	0.1343	0.1265	0.1200	0.1144	0.1095	0.1053	0.1016	0.0983	0.0954	0.0928	0.0904	0.0884	0.0865
4.0	6.14	0.1921	0.1839	0.1750	0.1683	0.1611	0.1556	0.1497	0.1402	0.1322	0.1254	0.1195	0.1145	0.1101	0.1062	0.1028	0.0998	0.0970	0.0945	0.0924	0.0904
4.1	6.30	0.2002	0.1917	0.1824	0.1755	0.1680	0.1623	0.1561	0.1463	0.1379	0.1308	0.1248	0.1195	0.1149	0.1108	0.1073	0.1042	0.1013	0.0987	0.0966	0.0945
4.2	6.45	0.2084	0.1996	0.1900	0.1828	0.1750	0.1691	0.1627	0.1524	0.1437	0.1364	0.1301	0.1246	0.1198	0.1156	0.1119	0.1087	0.1057	0.1030	0.1007	0.0986
4.3	6.60	0.2168	0.2076	0.1977	0.1902	0.1822	0.1760	0.1694	0.1587	0.1497	0.1420	0.1355	0.1298	0.1249	0.1205	0.1166	0.1133	0.1102	0.1073	0.1050	0.1027
4.4	6.76	0.2253	0.2158	0.2055	0.1978	0.1894	0.1830	0.1762	0.1651	0.1557	0.1478	0.1410	0.1351	0.1300	0.1254	0.1214	0.1179	0.1147	0.1118	0.1094	0.1070
4.5	6.91	0.2340	0.2242	0.2135	0.2055	0.1968	0.1902	0.1831	0.1716	0.1619	0.1537	0.1466	0.1405	0.1352	0.1304	0.1263	0.1227	0.1193	0.1163	0.1138	0.1113
4.6	7.06	0.2428	0.2326	0.2216	0.2133	0.2043	0.1975	0.1901	0.1782	0.1682	0.1596	0.1523	0.1460	0.1405	0.1356	0.1313	0.1275	0.1240	0.1209	0.1183	0.1158
4.7	7.22	0.2517	0.2412	0.2298	0.2212	0.2119	0.2048	0.1972	0.1849	0.1745	0.1657	0.1581	0.1516	0.1458	0.1408	0.1363	0.1324	0.1288	0.1256	0.1229	0.1202
4.8	7.37	0.2608	0.2499	0.2381	0.2293	0.2197	0.2123	0.2044	0.1917	0.1810	0.1718	0.1640	0.1572	0.1513	0.1461	0.1415	0.1374	0.1337	0.1303	0.1275	0.1248
4.9	7.53	0.2700	0.2588	0.2466	0.2374	0.2275	0.2199	0.2118	0.1987	0.1875	0.1781	0.1700	0.1630	0.1569	0.1514	0.1467	0.1425	0.1386	0.1351	0.1323	0.1295
5.0	7.68	0.2793	0.2677	0.2552	0.2457	0.2355	0.2277	0.2192	0.2057	0.1942	0.1844	0.1761	0.1688	0.1625	0.1569	0.1520	0.1477	0.1437	0.1401	0.1371	0.1342
5.1	7.83	0.2888	0.2768	0.2639	0.2541	0.2436	0.2355	0.2268	0.2128	0.2010	0.1909	0.1823	0.1748	0.1682	0.1624	0.1574	0.1529	0.1488	0.1450	0.1420	0.1390
5.2	7.99	0.2984	0.2861	0.2727	0.2626	0.2518	0.2435	0.2345	0.2201	0.2078	0.1974	0.1885	0.1808	0.1740	0.1681	0.1628	0.1582	0.1540	0.1501	0.1469	0.1438
5.3	8.14	0.3081	0.2954	0.2816	0.2713	0.2601	0.2515	0.2423	0.2274	0.2148	0.2041	0.1949	0.1869	0.1799	0.1738	0.1684	0.1636	0.1592	0.1552	0.1520	0.1488
5.4	8.29	0.3179	0.3049	0.2907	0.2801	0.2685	0.2597	0.2502	0.2348	0.2218	0.2108	0.2013	0.1931	0.1859	0.1796	0.1740	0.1691	0.1646	0.1605	0.1571	0.1538
5.5	8.45	0.3279	0.3145	0.2999	0.2890	0.2771	0.2680	0.2582	0.2424	0.2290	0.2176	0.2079	0.1994	0.1920	0.1855	0.1797	0.1747	0.1700	0.1657	0.1623	0.1589
5.6	8.60	0.3380	0.3242	0.3092	0.2980	0.2857	0.2764	0.2663	0.2500	0.2363	0.2246	0.2145	0.2058	0.1982	0.1914	0.1855	0.1803	0.1755	0.1711	0.1675	0.1640

Sizing in this region will lead to excessive head loss conditions.

Recommended Head Loss Design Range

Appendix E

MLC Hydronic Friction Loss Tables

1" Uponor MLC — 100% Water — Feet of Head per 100 Feet of Tubing

Velocity (ft./sec.)	GPM	40°F 4°C	45°F 7°C	50°F 10°C	55°F 13°C	60°F 16°C	65°F 18°C	70°F 21°C	80°F 27°C	90°F 32°C	100°F 38°C	110°F 43°C	120°F 49°C	130°F 54°C	140°F 60°C	150°F 66°C	160°F 71°C	170°F 77°C	180°F 82°C	190°F 88°C	200°F 93°C
1.5	3.78	1.47	1.39	1.31	1.29	1.26	1.24	1.22	1.18	1.14	1.11	1.09	1.06	1.04	1.02	1.00	0.98	0.97	0.95	0.94	0.92
1.6	4.03	1.64	1.56	1.47	1.44	1.41	1.39	1.36	1.32	1.28	1.25	1.22	1.19	1.16	1.14	1.12	1.10	1.08	1.07	1.05	1.04
1.7	4.28	1.82	1.73	1.63	1.60	1.57	1.54	1.51	1.47	1.42	1.39	1.35	1.32	1.29	1.27	1.25	1.22	1.21	1.19	1.17	1.15
1.8	4.53	2.01	1.91	1.80	1.77	1.73	1.70	1.67	1.62	1.57	1.53	1.50	1.46	1.43	1.40	1.38	1.36	1.33	1.31	1.30	1.28
1.9	4.78	2.20	2.10	1.98	1.94	1.91	1.87	1.84	1.78	1.73	1.69	1.65	1.61	1.58	1.54	1.52	1.49	1.47	1.45	1.43	1.41
2.0	5.03	2.41	2.29	2.17	2.13	2.08	2.05	2.01	1.95	1.89	1.84	1.80	1.76	1.72	1.69	1.66	1.63	1.61	1.58	1.56	1.54
2.1	5.29	2.62	2.50	2.36	2.31	2.27	2.23	2.19	2.12	2.06	2.01	1.96	1.92	1.88	1.84	1.81	1.78	1.75	1.73	1.70	1.68
2.2	5.54	2.84	2.71	2.56	2.51	2.46	2.42	2.38	2.30	2.24	2.18	2.13	2.08	2.04	2.00	1.97	1.93	1.90	1.88	1.85	1.83
2.3	5.79	3.07	2.92	2.76	2.71	2.66	2.62	2.57	2.49	2.42	2.36	2.30	2.25	2.21	2.17	2.13	2.09	2.06	2.03	2.00	1.98
2.4	6.04	3.30	3.15	2.98	2.92	2.87	2.82	2.77	2.68	2.61	2.54	2.48	2.43	2.38	2.34	2.30	2.26	2.22	2.19	2.16	2.13
2.5	6.29	3.54	3.38	3.20	3.14	3.08	3.03	2.98	2.88	2.81	2.73	2.67	2.61	2.56	2.51	2.47	2.43	2.39	2.36	2.32	2.29
2.6	6.55	3.79	3.62	3.42	3.36	3.30	3.24	3.19	3.09	3.01	2.93	2.86	2.80	2.74	2.69	2.65	2.60	2.56	2.53	2.49	2.46
2.7	6.80	4.05	3.87	3.66	3.59	3.52	3.47	3.41	3.30	3.21	3.13	3.06	2.99	2.93	2.88	2.83	2.78	2.74	2.70	2.67	2.63
2.8	7.05	4.31	4.12	3.90	3.83	3.76	3.69	3.63	3.52	3.43	3.34	3.26	3.19	3.13	3.07	3.02	2.97	2.93	2.88	2.85	2.81
2.9	7.30	4.59	4.38	4.15	4.07	3.99	3.93	3.86	3.75	3.65	3.55	3.47	3.40	3.33	3.27	3.21	3.16	3.11	3.07	3.03	2.99
3.0	7.55	4.87	4.65	4.40	4.32	4.24	4.17	4.10	3.98	3.87	3.77	3.69	3.61	3.54	3.47	3.41	3.36	3.31	3.26	3.22	3.18
3.1	7.80	5.15	4.92	4.66	4.58	4.49	4.42	4.34	4.21	4.10	4.00	3.91	3.83	3.75	3.68	3.62	3.56	3.51	3.46	3.41	3.37
3.2	8.06	5.44	5.20	4.93	4.84	4.75	4.67	4.59	4.46	4.34	4.23	4.13	4.05	3.97	3.90	3.83	3.77	3.71	3.66	3.61	3.57
3.3	8.31	5.74	5.49	5.20	5.11	5.01	4.93	4.85	4.71	4.58	4.47	4.37	4.27	4.19	4.12	4.05	3.98	3.92	3.87	3.82	3.77
3.4	8.56	6.05	5.78	5.48	5.38	5.28	5.20	5.11	4.96	4.83	4.71	4.60	4.51	4.42	4.34	4.27	4.20	4.14	4.08	4.03	3.98
3.5	8.81	6.37	6.09	5.77	5.67	5.56	5.47	5.38	5.22	5.08	4.96	4.85	4.75	4.65	4.57	4.49	4.42	4.36	4.30	4.24	4.19
3.6	9.06	6.69	6.39	6.06	5.95	5.84	5.75	5.65	5.49	5.34	5.21	5.10	4.99	4.89	4.81	4.73	4.65	4.58	4.52	4.46	4.41
3.7	9.31	7.01	6.71	6.36	6.25	6.13	6.04	5.94	5.76	5.61	5.47	5.35	5.24	5.14	5.05	4.96	4.89	4.81	4.75	4.69	4.63
3.8	9.57	7.35	7.03	6.66	6.55	6.43	6.33	6.22	6.04	5.88	5.74	5.61	5.49	5.39	5.29	5.21	5.12	5.05	4.98	4.92	4.86
3.9	9.82	7.69	7.36	6.98	6.86	6.73	6.62	6.51	6.33	6.16	6.01	5.88	5.75	5.65	5.55	5.45	5.37	5.29	5.22	5.15	5.09
4.0	10.07	8.04	7.69	7.29	7.17	7.04	6.93	6.81	6.62	6.44	6.29	6.15	6.02	5.91	5.80	5.71	5.62	5.53	5.46	5.39	5.32
4.1	10.32	8.39	8.03	7.62	7.49	7.35	7.24	7.12	6.91	6.73	6.57	6.42	6.29	6.17	6.06	5.96	5.87	5.78	5.71	5.63	5.57
4.2	10.57	8.76	8.38	7.95	7.81	7.67	7.55	7.43	7.21	7.03	6.86	6.71	6.57	6.44	6.33	6.23	6.13	6.04	5.96	5.88	5.81
4.3	10.82	9.12	8.73	8.29	8.14	7.99	7.87	7.74	7.52	7.32	7.15	6.99	6.85	6.72	6.60	6.49	6.39	6.30	6.22	6.14	6.06
4.4	11.08	9.50	9.09	8.63	8.48	8.33	8.20	8.06	7.83	7.63	7.45	7.28	7.14	7.00	6.88	6.77	6.66	6.57	6.48	6.40	6.32
4.5	11.33	9.88	9.46	8.98	8.82	8.66	8.53	8.39	8.15	7.94	7.75	7.58	7.43	7.29	7.16	7.04	6.94	6.84	6.74	6.66	6.58
4.6	11.58	10.27	9.83	9.33	9.17	9.01	8.87	8.72	8.48	8.26	8.06	7.89	7.73	7.58	7.45	7.33	7.22	7.11	7.02	6.93	6.85
4.7	11.83	10.66	10.21	9.69	9.53	9.36	9.21	9.06	8.81	8.58	8.38	8.19	8.03	7.88	7.74	7.61	7.50	7.39	7.29	7.20	7.12
4.8	12.08	11.07	10.60	10.06	9.89	9.71	9.56	9.41	9.14	8.91	8.70	8.51	8.34	8.18	8.04	7.91	7.79	7.68	7.57	7.48	7.39

Continued on next page

Recommended Head Loss Design Range

Sizing in this region will lead to excessive head loss conditions.

Appendix E MLC Hydronic Friction Loss Tables

1" Uponor MLC — 100% Water — Feet of Head per 100 Feet of Tubing

Velocity (ft./sec.)	GPM	40°F 4°C	45°F 7°C	50°F 10°C	55°F 13°C	60°F 16°C	65°F 18°C	70°F 21°C	80°F 27°C	90°F 32°C	100°F 38°C	110°F 43°C	120°F 49°C	130°F 54°C	140°F 60°C	150°F 66°C	160°F 71°C	170°F 77°C	180°F 82°C	190°F 88°C	200°F 93°C
4.9	12.33	11.47	10.99	10.43	10.26	10.07	9.92	9.76	9.48	9.24	9.02	8.83	8.65	8.49	8.34	8.21	8.08	7.97	7.86	7.76	7.67
5.0	12.59	11.89	11.38	10.81	10.63	10.44	10.28	10.12	9.83	9.58	9.35	9.15	8.97	8.80	8.65	8.51	8.38	8.26	8.15	8.05	7.95
5.1	12.84	12.31	11.79	11.20	11.01	10.81	10.65	10.48	10.18	9.92	9.69	9.48	9.29	9.12	8.96	8.82	8.68	8.56	8.45	8.34	8.24
5.2	13.09	12.74	12.20	11.59	11.39	11.19	11.02	10.84	10.54	10.27	10.03	9.81	9.62	9.44	9.28	9.13	8.99	8.86	8.75	8.64	8.54
5.3	13.34	13.17	12.62	11.99	11.78	11.57	11.40	11.22	10.90	10.63	10.38	10.15	9.95	9.77	9.60	9.45	9.31	9.17	9.05	8.94	8.84
5.4	13.59	13.61	13.04	12.39	12.18	11.96	11.78	11.60	11.27	10.99	10.73	10.50	10.29	10.10	9.93	9.77	9.62	9.49	9.36	9.25	9.14
5.5	13.85	14.06	13.47	12.80	12.58	12.36	12.17	11.98	11.65	11.35	11.09	10.85	10.63	10.44	10.26	10.10	9.95	9.80	9.68	9.56	9.45
5.6	14.10	14.51	13.90	13.21	12.99	12.76	12.57	12.37	12.03	11.72	11.45	11.20	10.98	10.78	10.60	10.43	10.27	10.13	10.00	9.87	9.76
5.7	14.35	14.97	14.34	13.63	13.41	13.17	12.97	12.77	12.41	12.10	11.82	11.56	11.34	11.13	10.94	10.76	10.61	10.45	10.32	10.19	10.07
5.8	14.60	15.43	14.79	14.06	13.83	13.58	13.38	13.17	12.80	12.48	12.19	11.93	11.69	11.48	11.29	11.11	10.94	10.79	10.65	10.52	10.40
5.9	14.85	15.91	15.24	14.49	14.25	14.00	13.79	13.57	13.20	12.87	12.57	12.30	12.06	11.84	11.64	11.45	11.28	11.12	10.98	10.85	10.72
6.0	15.10	16.38	15.70	14.93	14.68	14.42	14.21	13.98	13.60	13.26	12.95	12.68	12.43	12.20	11.99	11.80	11.63	11.47	11.32	11.18	11.05
6.1	15.36	16.87	16.17	15.37	15.12	14.85	14.63	14.40	14.01	13.65	13.34	13.06	12.80	12.57	12.36	12.16	11.98	11.81	11.66	11.52	11.39
6.2	15.61	17.36	16.64	15.82	15.56	15.29	15.06	14.82	14.42	14.06	13.73	13.44	13.18	12.94	12.72	12.52	12.34	12.16	12.01	11.86	11.73
6.3	15.86	17.85	17.12	16.28	16.01	15.73	15.50	15.25	14.83	14.46	14.13	13.83	13.56	13.32	13.09	12.89	12.70	12.52	12.36	12.21	12.07
6.4	16.11	18.36	17.60	16.74	16.46	16.17	15.94	15.69	15.26	14.88	14.53	14.23	13.95	13.70	13.47	13.26	13.06	12.88	12.72	12.56	12.42
6.5	16.36	18.86	18.09	17.20	16.92	16.63	16.38	16.13	15.68	15.29	14.94	14.63	14.34	14.09	13.85	13.63	13.43	13.25	13.08	12.92	12.77
6.6	16.61	19.38	18.58	17.68	17.39	17.08	16.83	16.57	16.12	15.72	15.36	15.04	14.74	14.48	14.24	14.01	13.81	13.62	13.44	13.28	13.13
6.7	16.87	19.90	19.08	18.15	17.86	17.55	17.29	17.02	16.56	16.15	15.78	15.45	15.15	14.87	14.63	14.40	14.19	13.99	13.81	13.65	13.49
6.8	17.12	20.43	19.59	18.64	18.33	18.02	17.75	17.48	17.00	16.58	16.20	15.86	15.55	15.28	15.02	14.79	14.57	14.37	14.19	14.02	13.86
6.9	17.37	20.96	20.10	19.13	18.82	18.49	18.22	17.94	17.45	17.02	16.63	16.28	15.97	15.68	15.42	15.18	14.96	14.75	14.57	14.39	14.23
7.0	17.62	21.50	20.62	19.62	19.30	18.97	18.69	18.40	17.90	17.46	17.06	16.71	16.39	16.09	15.83	15.58	15.35	15.14	14.95	14.77	14.60
7.1	17.87	22.05	21.15	20.12	19.80	19.45	19.17	18.87	18.36	17.91	17.50	17.14	16.81	16.51	16.23	15.98	15.75	15.53	15.34	15.15	14.98
7.2	18.12	22.60	21.68	20.63	20.29	19.94	19.65	19.35	18.83	18.36	17.95	17.57	17.24	16.93	16.65	16.39	16.15	15.93	15.73	15.54	15.37
7.3	18.38	23.15	22.21	21.14	20.80	20.44	20.14	19.83	19.30	18.82	18.40	18.02	17.67	17.35	17.07	16.80	16.56	16.33	16.13	15.94	15.76
7.4	18.63	23.72	22.75	21.66	21.31	20.94	20.64	20.32	19.77	19.29	18.85	18.46	18.11	17.78	17.49	17.22	16.97	16.74	16.53	16.33	16.15
7.5	18.88	24.29	23.30	22.18	21.82	21.45	21.14	20.81	20.25	19.76	19.31	18.91	18.55	18.22	17.92	17.64	17.39	17.15	16.93	16.73	16.55
7.6	19.13	24.86	23.86	22.71	22.34	21.96	21.64	21.31	20.74	20.23	19.77	19.37	18.99	18.66	18.35	18.07	17.81	17.56	17.34	17.14	16.95
7.7	19.38	25.44	24.41	23.24	22.87	22.48	22.15	21.81	21.23	20.71	20.24	19.83	19.45	19.10	18.79	18.50	18.23	17.98	17.76	17.55	17.35
7.8	19.64	26.03	24.98	23.78	23.40	23.00	22.67	22.32	21.72	21.19	20.72	20.29	19.90	19.55	19.23	18.93	18.66	18.41	18.18	17.96	17.76
7.9	19.89	26.62	25.55	24.33	23.94	23.53	23.19	22.83	22.22	21.68	21.20	20.76	20.36	20.00	19.68	19.37	19.10	18.84	18.60	18.38	18.18
8.0	20.14	27.22	26.13	24.88	24.48	24.06	23.72	23.35	22.73	22.18	21.68	21.23	20.83	20.46	20.13	19.82	19.54	19.27	19.03	18.81	18.60

Sizing in this region will lead to excessive head loss conditions.

Recommended Head Loss Design Range

Appendix E

MLC Hydronic Friction Loss Tables

1" Uponor MLC — 30% Propylene Glycol — Feet of Head per 100 Feet of Tubing

Velocity (ft./sec.)	GPM	40°F 4°C	45°F 7°C	50°F 10°C	55°F 13°C	60°F 16°C	65°F 18°C	70°F 21°C	80°F 27°C	90°F 32°C	100°F 38°C	110°F 43°C	120°F 49°C	130°F 54°C	140°F 60°C	150°F 66°C	160°F 71°C	170°F 77°C	180°F 82°C	190°F 88°C	200°F 93°C
1.5	3.78	2.0067	1.9363	1.8609	1.8025	1.7401	1.6898	1.6363	1.5495	1.4749	1.4107	1.3545	1.3068	1.2640	1.2251	1.1940	1.1635	1.1355	1.1121	1.0891	1.0720
1.6	4.03	2.2366	2.1588	2.0755	2.0108	1.9418	1.8861	1.8269	1.7308	1.6481	1.5769	1.5145	1.4615	1.4141	1.3709	1.3363	1.3024	1.2713	1.2454	1.2197	1.2008
1.7	4.28	2.4769	2.3914	2.2998	2.2287	2.1528	2.0916	2.0264	1.9205	1.8294	1.7509	1.6822	1.6238	1.5714	1.5237	1.4856	1.4482	1.4138	1.3851	1.3568	1.3359
1.8	4.53	2.7275	2.6340	2.5339	2.4561	2.3731	2.3060	2.2346	2.1187	2.0189	1.9328	1.8574	1.7934	1.7359	1.6836	1.6417	1.6006	1.5629	1.5314	1.5003	1.4773
1.9	4.78	2.9881	2.8864	2.7775	2.6928	2.6024	2.5293	2.4515	2.3252	2.2163	2.1225	2.0402	1.9702	1.9075	1.8504	1.8046	1.7598	1.7185	1.6841	1.6501	1.6249
2.0	5.03	3.2588	3.1486	3.0305	2.9386	2.8406	2.7614	2.6770	2.5398	2.4217	2.3197	2.2303	2.1543	2.0861	2.0240	1.9742	1.9254	1.8805	1.8431	1.8061	1.7787
2.1	5.29	3.5392	3.4203	3.2928	3.1936	3.0877	3.0021	2.9109	2.7626	2.6348	2.5246	2.4278	2.3455	2.2717	2.2044	2.1505	2.0976	2.0490	2.0084	1.9683	1.9386
2.2	5.54	3.8295	3.7016	3.5643	3.4576	3.3436	3.2514	3.1532	2.9935	2.8557	2.7369	2.6325	2.5438	2.4641	2.3915	2.3333	2.2763	2.2237	2.1800	2.1367	2.1046
2.3	5.79	4.1293	3.9922	3.8450	3.7305	3.6082	3.5092	3.4038	3.2323	3.0843	2.9566	2.8444	2.7490	2.6633	2.5853	2.5227	2.4613	2.4048	2.3577	2.3111	2.2766
2.4	6.04	4.4387	4.2921	4.1347	4.0122	3.8813	3.7754	3.6626	3.4789	3.3205	3.1836	3.0634	2.9612	2.8693	2.7856	2.7185	2.6527	2.5921	2.5415	2.4915	2.4545
2.5	6.29	4.7576	4.6012	4.4333	4.3026	4.1630	4.0500	3.9295	3.7334	3.5641	3.4179	3.2895	3.1802	3.0820	2.9925	2.9208	2.8504	2.7855	2.7314	2.6779	2.6383
2.6	6.55	5.0857	4.9194	4.7408	4.6017	4.4530	4.3327	4.2045	3.9956	3.8153	3.6595	3.5226	3.4061	3.3014	3.2059	3.1294	3.0543	2.9851	2.9273	2.8703	2.8280
2.7	6.80	5.4232	5.2466	5.0570	4.9094	4.7515	4.6237	4.4874	4.2655	4.0738	3.9081	3.7626	3.6386	3.5273	3.4257	3.3443	3.2643	3.1907	3.1293	3.0685	3.0235
2.8	7.05	5.7698	5.5828	5.3819	5.2255	5.0582	4.9227	4.7783	4.5429	4.3397	4.1639	4.0095	3.8779	3.7597	3.6519	3.5654	3.4806	3.4023	3.3371	3.2726	3.2248
2.9	7.30	6.1256	5.9279	5.7155	5.5501	5.3731	5.2298	5.0770	4.8280	4.6128	4.4268	4.2632	4.1239	3.9987	3.8845	3.7928	3.7029	3.6200	3.5509	3.4824	3.4318
3.0	7.55	6.4904	6.2818	6.0577	5.8830	5.6962	5.5449	5.3835	5.1205	4.8932	4.6966	4.5237	4.3765	4.2441	4.1233	4.0264	3.9313	3.8436	3.7705	3.6981	3.6445
3.1	7.80	6.8641	6.6444	6.4083	6.2243	6.0274	5.8680	5.6978	5.4205	5.1807	4.9734	4.7910	4.6356	4.4959	4.3684	4.2661	4.1657	4.0731	3.9959	3.9194	3.8629
3.2	8.06	7.2468	7.0157	6.7674	6.5738	6.3666	6.1988	6.0198	5.7278	5.4754	5.2570	5.0649	4.9012	4.7540	4.6197	4.5119	4.4061	4.3085	4.2271	4.1465	4.0869
3.3	8.31	7.6383	7.3957	7.1348	6.9315	6.7139	6.5376	6.3494	6.0425	5.7772	5.5476	5.3455	5.1734	5.0185	4.8772	4.7638	4.6524	4.5497	4.4641	4.3793	4.3165
3.4	8.56	8.0385	7.7842	7.5106	7.2973	7.0690	6.8840	6.6866	6.3645	6.0860	5.8449	5.6327	5.4519	5.2893	5.1409	5.0217	4.9047	4.7968	4.7067	4.6176	4.5516
3.5	8.81	8.4475	8.1811	7.8946	7.6712	7.4320	7.2382	7.0313	6.6938	6.4018	6.1490	5.9265	5.7369	5.5663	5.4106	5.2856	5.1628	5.0496	4.9551	4.8616	4.7923
3.6	9.06	8.8652	8.5866	8.2868	8.0531	7.8029	7.6001	7.3835	7.0302	6.7245	6.4599	6.2269	6.0283	5.8496	5.6864	5.5554	5.4268	5.3082	5.2092	5.1111	5.0385
3.7	9.31	9.2914	9.0004	8.6872	8.4430	8.1815	7.9696	7.7432	7.3739	7.0542	6.7774	6.5337	6.3259	6.1390	5.9683	5.8312	5.6966	5.5724	5.4688	5.3662	5.2902
3.8	9.57	9.7262	9.4225	9.0958	8.8409	8.5679	8.3466	8.1103	7.7246	7.3908	7.1016	6.8470	6.6299	6.4345	6.2562	6.1129	5.9722	5.8424	5.7341	5.6268	5.5474
3.9	9.82	10.1695	9.8530	9.5123	9.2466	8.9620	8.7312	8.4847	8.0824	7.7342	7.4324	7.1667	6.9402	6.7362	6.5500	6.4005	6.2536	6.1180	6.0049	5.8929	5.8100
4.0	10.07	10.6213	10.2917	9.9369	9.6602	9.3637	9.1233	8.8665	8.4473	8.0843	7.7699	7.4929	7.2567	7.0440	6.8498	6.6939	6.5407	6.3993	6.2813	6.1645	6.0779
4.1	10.32	11.0814	10.7386	10.3695	10.0816	9.7730	9.5228	9.2556	8.8192	8.4413	8.1138	7.8254	7.5794	7.3579	7.1556	6.9931	6.8335	6.6862	6.5632	6.4415	6.3513
4.2	10.57	11.5499	11.1937	10.8100	10.5107	10.1899	9.9298	9.6519	9.1981	8.8050	8.4643	8.1642	7.9082	7.6777	7.4672	7.2981	7.1320	6.9786	6.8507	6.7239	6.6300
4.3	10.82	12.0268	11.6568	11.2585	10.9475	10.6144	10.3442	10.0554	9.5839	9.1754	8.8213	8.5094	8.2433	8.0036	7.7847	7.6089	7.4361	7.2767	7.1436	7.0117	6.9141
4.4	11.08	12.5119	12.1281	11.7147	11.3921	11.0463	10.7658	10.4661	9.9766	9.5525	9.1848	8.8608	8.5844	8.3355	8.1081	7.9254	7.7459	7.5802	7.4419	7.3049	7.2034
4.5	11.33	13.0052	12.6074	12.1788	11.8443	11.4857	11.1948	10.8840	10.3762	9.9362	9.5547	9.2185	8.9316	8.6733	8.4372	8.2476	8.0613	7.8893	7.7457	7.6035	7.4981
4.6	11.58	13.5068	13.0946	12.6507	12.3041	11.9325	11.6311	11.3089	10.7826	10.3265	9.9310	9.5824	9.2849	9.0170	8.7722	8.5755	8.3822	8.2038	8.0549	7.9073	7.7980
4.7	11.83	14.0164	13.5898	13.1302	12.7714	12.3867	12.0746	11.7410	11.1959	10.7234	10.3137	9.9525	9.6443	9.3666	9.1130	8.9091	8.7088	8.5238	8.3694	8.2165	8.1032
4.8	12.08	14.5342	14.0930	13.6175	13.2463	12.8483	12.5253	12.1801	11.6159	11.1269	10.7027	10.3288	10.0097	9.7222	9.4594	9.2483	9.0408	8.8493	8.6894	8.5310	8.4136

Continued on next page

Recommended Head Loss Design Range

Sizing in this region will lead to excessive head loss conditions.

Appendix E

MLC Hydronic Friction Loss Tables

1" Uponor MLC — 30% Propylene Glycol — Feet of Head per 100 Feet of Tubing

Velocity (ft./sec.)	GPM	40°F 4°C	45°F 7°C	50°F 10°C	55°F 13°C	60°F 16°C	65°F 18°C	70°F 21°C	80°F 27°C	90°F 32°C	100°F 38°C	110°F 43°C	120°F 49°C	130°F 54°C	140°F 60°C	150°F 66°C	160°F 71°C	170°F 77°C	180°F 82°C	190°F 88°C	200°F 93°C
4.9	12.33	15.0601	14.6040	14.1125	13.7287	13.3172	12.9832	12.6262	12.0427	11.5369	11.0981	10.7112	10.3810	10.0835	9.8117	9.5932	9.3784	9.1802	9.0147	8.8507	8.7292
5.0	12.59	15.5940	15.1229	14.6151	14.2186	13.7934	13.4483	13.0793	12.4763	11.9534	11.4998	11.0998	10.7584	10.4507	10.1696	9.9436	9.7215	9.5165	9.3453	9.1757	9.0500
5.1	12.84	16.1359	15.6496	15.1253	14.7159	14.2768	13.9204	13.5394	12.9165	12.3764	11.9077	11.4945	11.1416	10.8237	10.5332	10.2997	10.0701	9.8582	9.6812	9.5059	9.3760
5.2	13.09	16.6858	16.1840	15.6431	15.2206	14.7675	14.3997	14.0064	13.3634	12.8058	12.3219	11.8952	11.5309	11.2025	10.9025	10.6613	10.4242	10.2053	10.0225	9.8414	9.7071
5.3	13.34	17.2436	16.7262	16.1685	15.7327	15.2654	14.8860	14.4803	13.8170	13.2416	12.7423	12.3020	11.9260	11.5871	11.2774	11.0284	10.7837	10.5577	10.3690	10.1820	10.0434
5.4	13.59	17.8094	17.2761	16.7013	16.2522	15.7704	15.3793	14.9611	14.2772	13.6839	13.1690	12.7148	12.3270	11.9774	11.6579	11.4011	11.1486	10.9154	10.7207	10.5278	10.3848
5.5	13.85	18.3830	17.8338	17.2416	16.7790	16.2826	15.8797	15.4487	14.7440	14.1325	13.6018	13.1336	12.7338	12.3735	12.0441	11.7793	11.5189	11.2785	11.0777	10.8788	10.7313
5.6	14.10	18.9644	18.3990	17.7894	17.3130	16.8020	16.3870	15.9432	15.2173	14.5875	14.0408	13.5585	13.1466	12.7753	12.4358	12.1629	11.8946	11.6469	11.4399	11.2349	11.0829
5.7	14.35	19.5537	18.9719	18.3446	17.8544	17.3284	16.9013	16.4444	15.6972	15.0488	14.4859	13.9893	13.5651	13.1827	12.8331	12.5521	12.2757	12.0205	11.8074	11.5962	11.4396
5.8	14.60	20.1507	19.5524	18.9072	18.4029	17.8619	17.4225	16.9525	16.1837	15.5165	14.9372	14.4260	13.9894	13.5959	13.2360	12.9466	12.6622	12.3994	12.1800	11.9625	11.8014
5.9	14.85	20.7555	20.1405	19.4771	18.9587	18.4024	17.9506	17.4673	16.6767	15.9904	15.3945	14.8687	14.4196	14.0146	13.6444	13.3467	13.0539	12.7836	12.5578	12.3340	12.1682
6.0	15.10	21.3680	20.7361	20.0545	19.5217	18.9500	18.4856	17.9888	17.1761	16.4706	15.8579	15.3173	14.8555	14.4391	14.0583	13.7521	13.4511	13.1730	12.9407	12.7106	12.5400
6.1	15.36	21.9882	21.3392	20.6391	20.0918	19.5045	19.0275	18.5171	17.6820	16.9570	16.3274	15.7718	15.2971	14.8691	14.4777	14.1630	13.8535	13.5676	13.3288	13.0922	12.9168
6.2	15.61	22.6161	21.9498	21.2310	20.6691	20.0660	19.5762	19.0520	18.1944	17.4497	16.8030	16.2322	15.7445	15.3048	14.9026	14.5792	14.2612	13.9674	13.7221	13.4789	13.2986
6.3	15.86	23.2516	22.5678	21.8302	21.2535	20.6345	20.1317	19.5936	18.7131	17.9486	17.2845	16.6984	16.1976	15.7460	15.3330	15.0008	14.6742	14.3725	14.1204	13.8706	13.6855
6.4	16.11	23.8947	23.1934	22.4366	21.8450	21.2099	20.6940	20.1418	19.2383	18.4537	17.7721	17.1705	16.6564	16.1928	15.7688	15.4278	15.0924	14.7827	14.5239	14.2674	14.0773
6.5	16.36	24.5454	23.8263	23.0503	22.4435	21.7922	21.2630	20.6967	19.7699	18.9650	18.2657	17.6484	17.1209	16.6452	16.2100	15.8601	15.5159	15.1980	14.9324	14.6692	14.4741
6.6	16.61	25.2037	24.4666	23.6711	23.0491	22.3814	21.8388	21.2582	20.3078	19.4824	18.7652	18.1321	17.5910	17.1031	16.6567	16.2977	15.9447	15.6185	15.3460	15.0760	14.8758
6.7	16.87	25.8696	25.1143	24.2992	23.6617	22.9774	22.4214	21.8262	20.8521	20.0059	19.2707	18.6216	18.0668	17.5665	17.1088	16.7407	16.3786	16.0441	15.7647	15.4878	15.2824
6.8	17.12	26.5429	25.7693	24.9343	24.2814	23.5803	23.0106	22.4008	21.4027	20.5356	19.7821	19.1169	18.5483	18.0354	17.5663	17.1889	16.8178	16.4749	16.1884	15.9045	15.6940
6.9	17.37	27.2238	26.4316	25.5767	24.9080	24.1900	23.6065	22.9820	21.9596	21.0714	20.2995	19.6179	19.0353	18.5099	18.0292	17.6425	17.2621	16.9108	16.6172	16.3262	16.1105
7.0	17.62	27.9121	27.1013	26.2261	25.5415	24.8065	24.2091	23.5697	22.5228	21.6132	20.8227	20.1247	19.5280	18.9898	18.4974	18.1013	17.7117	17.3517	17.0510	16.7529	16.5319
7.1	17.87	28.6078	27.7782	26.8826	26.1821	25.4298	24.8184	24.1639	23.0923	22.1611	21.3519	20.6372	20.0263	19.4751	18.9710	18.5653	18.1664	17.7978	17.4898	17.1846	16.9582
7.2	18.12	29.3110	28.4624	27.5462	26.8295	26.0598	25.4343	24.7646	23.6680	22.7151	21.8869	21.1554	20.5301	19.9660	19.4499	19.0347	18.6263	18.2489	17.9336	17.6211	17.3894
7.3	18.38	30.0216	29.1538	28.2168	27.4838	26.6966	26.0568	25.3717	24.2500	23.2751	22.4277	21.6793	21.0395	20.4623	19.9341	19.5092	19.0913	18.7051	18.3824	18.0626	17.8255
7.4	18.63	30.7396	29.8524	28.8944	28.1450	27.3401	26.6858	25.9853	24.8382	23.8412	22.9745	22.2090	21.5545	20.9640	20.4237	19.9890	19.5614	19.1663	18.8362	18.5090	18.2664
7.5	18.88	31.4650	30.5582	29.5791	28.8131	27.9903	27.3215	26.6054	25.4326	24.4132	23.5270	22.7442	22.0749	21.4711	20.9185	20.4740	20.0367	19.6326	19.2950	18.9603	18.7121
7.6	19.13	32.1977	31.2712	30.2708	29.4880	28.6472	27.9637	27.2319	26.0332	24.9912	24.0854	23.2852	22.6010	21.9836	21.4187	20.9642	20.5170	20.1039	19.7587	19.4164	19.1627
7.7	19.38	32.9377	31.9913	30.9694	30.1698	29.3108	28.6125	27.8647	26.6399	25.5752	24.6495	23.8318	23.1325	22.5015	21.9241	21.4595	21.0025	20.5802	20.2273	19.8775	19.6181
7.8	19.64	33.6850	32.7186	31.6750	30.8583	29.9810	29.2678	28.5040	27.2529	26.1652	25.2195	24.3840	23.6695	23.0248	22.4348	21.9601	21.4931	21.0615	20.7009	20.3434	20.0783
7.9	19.89	34.4396	33.4530	32.3875	31.5536	30.6579	29.9296	29.1496	27.8720	26.7611	25.7952	24.9418	24.2120	23.5534	22.9508	22.4658	21.9887	21.5478	21.1794	20.8142	20.5434
8.0	20.14	35.2015	34.1945	33.1069	32.2558	31.3413	30.5978	29.8016	28.4972	27.3630	26.3767	25.5052	24.7600	24.0874	23.4719	22.9766	22.4894	22.0391	21.6628	21.2898	21.0132

Appendix E

MLC Hydronic Friction Loss Tables

1" Uponor MLC — 40% Propylene Glycol — Feet of Head per 100 Feet of Tubing

Velocity (ft./sec.)	GPM	40°F 4°C	45°F 7°C	50°F 10°C	55°F 13°C	60°F 16°C	65°F 18°C	70°F 21°C	80°F 27°C	90°F 32°C	100°F 38°C	110°F 43°C	120°F 49°C	130°F 54°C	140°F 60°C	150°F 66°C	160°F 71°C	170°F 77°C	180°F 82°C	190°F 88°C	200°F 93°C
1.5	3.78	2.3720	2.2680	2.1557	2.0724	1.9830	1.9147	1.8416	1.7243	1.6259	1.5437	1.4730	1.4107	1.3577	1.3104	1.2705	1.2361	1.2018	1.1763	1.1476	1.1267
1.6	4.03	2.6399	2.5252	2.4012	2.3092	2.2104	2.1349	2.0541	1.9243	1.8154	1.7243	1.6459	1.5768	1.5181	1.4656	1.4213	1.3831	1.3450	1.3166	1.2848	1.2615
1.7	4.28	2.9196	2.7937	2.6577	2.5567	2.4481	2.3651	2.2763	2.1336	2.0137	1.9134	1.8271	1.7509	1.6861	1.6282	1.5794	1.5372	1.4951	1.4638	1.4287	1.4030
1.8	4.53	3.2109	3.0735	2.9250	2.8147	2.6960	2.6053	2.5081	2.3520	2.2207	2.1108	2.0163	1.9328	1.8617	1.7983	1.7446	1.6984	1.6522	1.6178	1.5792	1.5510
1.9	4.78	3.5136	3.3644	3.2029	3.0830	2.9539	2.8552	2.7494	2.5794	2.4364	2.3166	2.2135	2.1224	2.0449	1.9756	1.9171	1.8666	1.8161	1.7785	1.7364	1.7055
2.0	5.03	3.8276	3.6661	3.4914	3.3615	3.2217	3.1147	3.0001	2.8157	2.6605	2.5306	2.4186	2.3196	2.2354	2.1601	2.0965	2.0416	1.9867	1.9459	1.9000	1.8665
2.1	5.29	4.1528	3.9787	3.7902	3.6501	3.4992	3.3838	3.2600	3.0609	2.8931	2.7526	2.6315	2.5245	2.4333	2.3518	2.2829	2.2235	2.1640	2.1198	2.0701	2.0337
2.2	5.54	4.4889	4.3019	4.0993	3.9487	3.7864	3.6622	3.5290	3.3147	3.1341	2.9827	2.8522	2.7367	2.6385	2.5506	2.4762	2.4121	2.3479	2.3002	2.2465	2.2073
2.3	5.79	4.8359	4.6356	4.4186	4.2571	4.0832	3.9500	3.8071	3.5771	3.3832	3.2206	3.0805	2.9564	2.8509	2.7563	2.6764	2.6074	2.5384	2.4870	2.4293	2.3871
2.4	6.04	5.1937	4.9797	4.7479	4.5753	4.3894	4.2470	4.0941	3.8481	3.6406	3.4665	3.3163	3.1835	3.0703	2.9690	2.8833	2.8094	2.7353	2.6803	2.6183	2.5731
2.5	6.29	5.5621	5.3342	5.0871	4.9032	4.7049	4.5531	4.3901	4.1275	3.9060	3.7201	3.5597	3.4178	3.2969	3.1886	3.0970	3.0179	2.9387	2.8799	2.8136	2.7652
2.6	6.55	5.9410	5.6988	5.4362	5.2406	5.0298	4.8682	4.6947	4.4153	4.1794	3.9814	3.8106	3.6593	3.5304	3.4150	3.3173	3.2330	3.1485	3.0857	3.0151	2.9634
2.7	6.80	6.3304	6.0736	5.7950	5.5876	5.3638	5.1923	5.0081	4.7114	4.4608	4.2504	4.0688	3.9080	3.7709	3.6481	3.5443	3.4545	3.3647	3.2978	3.2226	3.1676
2.8	7.05	6.7302	6.4584	6.1635	5.9439	5.7069	5.5253	5.3302	5.0157	4.7501	4.5270	4.3344	4.1638	4.0183	3.8880	3.7778	3.6825	3.5871	3.5161	3.4363	3.3779
2.9	7.30	7.1402	6.8531	6.5416	6.3095	6.0591	5.8670	5.6608	5.3282	5.0472	4.8111	4.6072	4.4266	4.2726	4.1346	4.0178	3.9169	3.8158	3.7406	3.6559	3.5940
3.0	7.55	7.5603	7.2577	6.9292	6.6844	6.4202	6.2176	5.9999	5.6488	5.3520	5.1026	4.8872	4.6964	4.5336	4.3877	4.2643	4.1576	4.0507	3.9711	3.8816	3.8161
3.1	7.80	7.9906	7.6721	7.3263	7.0685	6.7902	6.5768	6.3474	5.9774	5.6646	5.4016	5.1745	4.9732	4.8014	4.6475	4.5172	4.4046	4.2917	4.2078	4.1132	4.0441
3.2	8.06	8.4309	8.0962	7.7327	7.4617	7.1690	6.9446	6.7033	6.3140	5.9848	5.7080	5.4688	5.2568	5.0759	4.9138	4.7765	4.6578	4.5389	4.4504	4.3508	4.2779
3.3	8.31	8.8810	8.5299	8.1484	7.8639	7.5566	7.3209	7.0675	6.6585	6.3126	6.0217	5.7703	5.5473	5.3571	5.1866	5.0421	4.9173	4.7922	4.6991	4.5943	4.5176
3.4	8.56	9.3411	8.9731	8.5733	8.2751	7.9529	7.7058	7.4400	7.0110	6.6480	6.3427	6.0787	5.8447	5.6449	5.4658	5.3141	5.1830	5.0515	4.9537	4.8436	4.7630
3.5	8.81	9.8109	9.4259	9.0074	8.6952	8.3579	8.0990	7.8207	7.3712	6.9909	6.6709	6.3942	6.1488	5.9393	5.7515	5.5923	5.4548	5.3169	5.2143	5.0987	5.0141
3.6	9.06	10.2905	9.8880	9.4506	9.1242	8.7714	8.5007	8.2095	7.7393	7.3412	7.0062	6.7166	6.4596	6.2403	6.0435	5.8768	5.7327	5.5883	5.4807	5.3596	5.2710
3.7	9.31	10.7797	10.3596	9.9028	9.5619	9.1935	8.9107	8.6065	8.1150	7.6990	7.3488	7.0459	6.7771	6.5477	6.3419	6.1675	6.0167	5.8656	5.7530	5.6263	5.5335
3.8	9.57	11.2786	10.8404	10.3640	10.0085	9.6241	9.3289	9.0115	8.4985	8.0641	7.6984	7.3820	7.1013	6.8616	6.6466	6.4644	6.3068	6.1488	6.0312	5.8987	5.8018
3.9	9.82	11.7869	11.3305	10.8342	10.4637	10.0630	9.7554	9.4245	8.8896	8.4366	8.0551	7.7250	7.4321	7.1820	6.9576	6.7674	6.6029	6.4379	6.3151	6.1768	6.0756
4.0	10.07	12.3048	11.8298	11.3132	10.9275	10.5104	10.1901	9.8454	9.2883	8.8163	8.4188	8.0748	7.7696	7.5088	7.2748	7.0765	6.9050	6.7330	6.6049	6.4606	6.3550
4.1	10.32	12.8320	12.3383	11.8011	11.4000	10.9661	10.6329	10.2743	9.6946	9.2033	8.7986	8.4314	8.1135	7.8420	7.5982	7.3917	7.2130	7.0338	6.9004	6.7500	6.6400
4.2	10.57	13.3687	12.8558	12.2977	11.8810	11.4301	11.0838	10.7111	10.1084	9.5976	9.1672	8.7947	8.4640	8.1815	7.9279	7.7129	7.5270	7.3405	7.2016	7.0451	6.9306
4.3	10.82	13.9147	13.3824	12.8031	12.3704	11.9024	11.5428	11.1556	10.5296	9.9990	9.5518	9.1647	8.8210	8.5273	8.2637	8.0402	7.8469	7.6529	7.5085	7.3458	7.2267
4.4	11.08	14.4699	13.9179	13.3172	12.8668	12.3828	12.0097	11.6080	10.9584	10.4075	9.9433	9.5414	9.1844	8.8794	8.6056	8.3735	8.1726	7.9712	7.8211	7.6520	7.5283
4.5	11.33	15.0343	14.4625	13.8399	13.3748	12.8714	12.4846	12.0682	11.3945	10.8232	10.3417	9.9247	9.5543	9.2378	8.9536	8.7127	8.5042	8.2951	8.1394	7.9638	7.8354
4.6	11.58	15.6080	15.0159	14.3712	13.8895	13.3682	12.9675	12.5361	11.8380	11.2460	10.7469	10.3146	9.9306	9.6025	9.3078	9.0579	8.8417	8.6248	8.4632	8.2812	8.1479
4.7	11.83	16.1907	15.5781	14.9111	14.4126	13.8730	13.4583	13.0116	12.2889	11.6758	11.1588	10.7111	10.3133	9.9733	9.6679	9.4090	9.1850	8.9602	8.7927	8.6040	8.4659
4.8	12.08	16.7825	16.1492	15.4595	14.9439	14.3859	13.9569	13.4948	12.7470	12.1126	11.5776	11.1141	10.7023	10.3503	10.0342	9.7660	9.5340	9.3012	9.1278	8.9324	8.7893

Continued on next page

Recommended Head Loss Design Range

Sizing in this region will lead to excessive head loss conditions.

Appendix E

MLC Hydronic Friction Loss Tables

1" Uponor MLC — 40% Propylene Glycol — Feet of Head per 100 Feet of Tubing

Velocity (ft./sec.)	GPM	40°F 4°C	45°F 7°C	50°F 10°C	55°F 13°C	60°F 16°C	65°F 18°C	70°F 21°C	80°F 27°C	90°F 32°C	100°F 38°C	110°F 43°C	120°F 49°C	130°F 54°C	140°F 60°C	150°F 66°C	160°F 71°C	170°F 77°C	180°F 82°C	190°F 88°C	200°F 93°C
4.9	12.33	17.3834	16.7291	16.0164	15.4836	14.9068	14.4633	13.9856	13.2125	12.5564	12.0031	11.5236	11.0977	10.7335	10.4064	10.1289	9.8888	9.6479	9.4685	9.2662	9.1181
5.0	12.59	17.9933	17.3176	16.5817	16.0314	15.4356	14.9775	14.4840	13.6852	13.0072	12.4353	11.9397	11.4993	11.1228	10.7846	10.4977	10.2494	10.0003	9.8146	9.6054	9.4523
5.1	12.84	18.6121	17.9149	17.1554	16.5874	15.9724	15.4995	14.9900	14.1651	13.4649	12.8742	12.3622	11.9073	11.5182	11.1687	10.8723	10.6157	10.3582	10.1664	9.9501	9.7918
5.2	13.09	19.2398	18.5208	17.7374	17.1516	16.5171	16.0292	15.5035	14.6522	13.9295	13.3197	12.7912	12.3214	11.9197	11.5588	11.2527	10.9877	10.7217	10.5236	10.3002	10.1367
5.3	13.34	19.8764	19.1354	18.3278	17.7239	17.0697	16.5666	16.0244	15.1464	14.4010	13.7719	13.2266	12.7419	12.3273	11.9548	11.6389	11.3653	11.0908	10.8863	10.6557	10.4869
5.4	13.59	20.5218	19.7585	18.9265	18.3042	17.6301	17.1116	16.5528	15.6478	14.8793	14.2307	13.6684	13.1685	12.7409	12.3567	12.0308	11.7487	11.4655	11.2544	11.0165	10.8424
5.5	13.85	21.1761	20.3901	19.5335	18.8926	18.1983	17.6643	17.0887	16.1563	15.3644	14.6960	14.1165	13.6013	13.1606	12.7645	12.4285	12.1376	11.8456	11.6281	11.3828	11.2032
5.6	14.10	21.8391	21.0303	20.1486	19.4890	18.7743	18.2245	17.6319	16.6719	15.8564	15.1680	14.5710	14.0403	13.5862	13.1782	12.8320	12.5322	12.2313	12.0071	11.7543	11.5692
5.7	14.35	22.5108	21.6789	20.7720	20.0934	19.3581	18.7924	18.1825	17.1945	16.3551	15.6464	15.0319	14.4854	14.0179	13.5977	13.2411	12.9324	12.6225	12.3916	12.1312	11.9405
5.8	14.60	23.1912	22.3360	21.4035	20.7057	19.9496	19.3677	18.7405	17.7242	16.8606	16.1314	15.4990	14.9366	14.4554	14.0230	13.6560	13.3382	13.0192	12.7814	12.5134	12.3171
5.9	14.85	23.8803	23.0015	22.0432	21.3260	20.5487	19.9506	19.3058	18.2608	17.3728	16.6229	15.9724	15.3939	14.8990	14.4540	14.0765	13.7495	13.4213	13.1767	12.9008	12.6989
6.0	15.10	24.5780	23.6753	22.6909	21.9541	21.1556	20.5410	19.8784	18.8044	17.8917	17.1208	16.4521	15.8574	15.3484	14.8909	14.5027	14.1664	13.8289	13.5773	13.2936	13.0858
6.1	15.36	25.2843	24.3575	23.3468	22.5902	21.7700	21.1388	20.4582	19.3550	18.4172	17.6252	16.9381	16.3268	15.8038	15.3336	14.9345	14.5888	14.2419	13.9832	13.6916	13.4780
6.2	15.61	25.9991	25.0481	24.0106	23.2340	22.3921	21.7441	21.0453	19.9125	18.9495	18.1360	17.4302	16.8024	16.2650	15.7819	15.3719	15.0168	14.6603	14.3945	14.0948	13.8754
6.3	15.86	26.7225	25.7469	24.6825	23.8857	23.0218	22.3568	21.6396	20.4769	19.4884	18.6532	17.9286	17.2839	16.7322	16.2360	15.8150	15.4503	15.0841	14.8111	14.5033	14.2779
6.4	16.11	27.4544	26.4539	25.3624	24.5451	23.6590	22.9768	22.2411	21.0482	20.0338	19.1768	18.4331	17.7715	17.2051	16.6959	16.2636	15.8892	15.5133	15.2330	14.9170	14.6855
6.5	16.36	28.1947	27.1692	26.0502	25.2123	24.3037	23.6042	22.8498	21.6263	20.5859	19.7068	18.9439	18.2650	17.6839	17.1614	16.7178	16.3336	15.9478	15.6602	15.3359	15.0983
6.6	16.61	28.9435	27.8927	26.7460	25.8872	24.9560	24.2390	23.4656	22.2113	21.1446	20.2431	19.4607	18.7645	18.1685	17.6326	17.1776	16.7835	16.3877	16.0927	15.7600	15.5163
6.7	16.87	29.7007	28.6243	27.4496	26.5698	25.6157	24.8810	24.0885	22.8031	21.7098	20.7858	19.9838	19.2700	18.6590	18.1094	17.6429	17.2388	16.8330	16.5304	16.1892	15.9393
6.8	17.12	30.4663	29.3641	28.1612	27.2601	26.2829	25.5304	24.7186	23.4018	22.2816	21.3347	20.5129	19.7814	19.1552	18.5919	18.1138	17.6995	17.2835	16.9734	16.6236	16.3674
6.9	17.37	31.2402	30.1120	28.8806	27.9581	26.9576	26.1870	25.3557	24.0071	22.8598	21.8900	21.0481	20.2987	19.6571	19.0801	18.5901	18.1657	17.7394	17.4216	17.0632	16.8006
7.0	17.62	32.0225	30.8680	29.6078	28.6637	27.6396	26.8509	25.9999	24.6193	23.4446	22.4515	21.5894	20.8220	20.1649	19.5738	19.0720	18.6372	18.2006	17.8750	17.5079	17.2389
7.1	17.87	32.8131	31.6321	30.3428	29.3769	28.3290	27.5219	26.6511	25.2382	24.0358	23.0193	22.1367	21.3511	20.6783	20.0732	19.5593	19.1142	18.6670	18.3337	17.9577	17.6822
7.2	18.12	33.6119	32.4042	31.0856	30.0977	29.0259	28.2002	27.3093	25.8638	24.6335	23.5934	22.6901	21.8861	21.1975	20.5781	20.0522	19.5965	19.1388	18.7975	18.4126	18.1306
7.3	18.38	34.4190	33.1844	31.8362	30.8260	29.7300	28.8857	27.9746	26.4961	25.2377	24.1736	23.2496	22.4269	21.7224	21.0886	20.5504	20.0841	19.6158	19.2665	18.8726	18.5840
7.4	18.63	35.2344	33.9725	32.5945	31.5619	30.4415	29.5783	28.6468	27.1351	25.8483	24.7601	23.8150	22.9736	22.2530	21.6047	21.0542	20.5771	20.0980	19.7407	19.3377	19.0425
7.5	18.88	36.0579	34.7686	33.3605	32.3053	31.1603	30.2781	29.3260	27.7807	26.4653	25.3527	24.3865	23.5262	22.7893	22.1263	21.5633	21.0755	20.5854	20.2200	19.8079	19.5059
7.6	19.13	36.8896	35.5726	34.1342	33.0562	31.8864	30.9850	30.0121	28.4330	27.0886	25.9516	24.9639	24.0845	23.3312	22.6535	22.0779	21.5791	21.0781	20.7045	20.2831	19.9744
7.7	19.38	37.7295	36.3846	34.9156	33.8146	32.6197	31.6990	30.7052	29.0920	27.7184	26.5565	25.5473	24.6486	23.8788	23.1862	22.5979	22.0881	21.5760	21.1942	20.7634	20.4478
7.8	19.64	38.5775	37.2045	35.7047	34.5804	33.3603	32.4200	31.4051	29.7575	28.3545	27.1677	26.1367	25.2186	24.4321	23.7244	23.1233	22.6024	22.0791	21.6889	21.2487	20.9262
7.9	19.89	39.4336	38.0322	36.5013	35.3537	34.1081	33.1482	32.1120	30.4296	28.9970	27.7849	26.7320	25.7943	24.9909	24.2680	23.6540	23.1219	22.5874	22.1888	21.7391	21.4096
8.0	20.14	40.2978	38.8678	37.3056	36.1344	34.8631	33.8834	32.8257	31.1084	29.6458	28.4083	27.3332	26.3757	25.5554	24.8172	24.1902	23.6467	23.1008	22.6937	22.2344	21.8979

Recommended Head Loss Design Range

Sizing in this region will lead to excessive head loss conditions.

Appendix E

MLC Hydronic Friction Loss Tables

1" Uponor MLC — 50% Propylene Glycol — Feet of Head per 100 Feet of Tubing

Velocity (ft./sec.)	GPM	40°F 4°C	45°F 7°C	50°F 10°C	55°F 13°C	60°F 16°C	65°F 18°C	70°F 21°C	80°F 27°C	90°F 32°C	100°F 38°C	110°F 43°C	120°F 49°C	130°F 54°C	140°F 60°C	150°F 66°C	160°F 71°C	170°F 77°C	180°F 82°C	190°F 88°C	200°F 93°C
1.5	3.78	2.7161	2.5882	2.4503	2.3474	2.2369	2.1528	2.0627	1.9191	1.7987	1.6973	1.6111	1.5367	1.4721	1.4154	1.3660	1.3227	1.2826	1.2466	1.2171	1.1882
1.6	4.03	3.0192	2.8783	2.7262	2.6128	2.4908	2.3980	2.2985	2.1398	2.0066	1.8944	1.7990	1.7165	1.6450	1.5821	1.5273	1.4792	1.4348	1.3947	1.3620	1.3299
1.7	4.28	3.3353	3.1809	3.0142	2.8898	2.7560	2.6541	2.5449	2.3706	2.2241	2.1007	1.9957	1.9048	1.8260	1.7567	1.6963	1.6433	1.5942	1.5501	1.5139	1.4785
1.8	4.53	3.6642	3.4959	3.3142	3.1784	3.0324	2.9211	2.8018	2.6112	2.4510	2.3160	2.2010	2.1015	2.0151	1.9391	1.8729	1.8148	1.7609	1.7125	1.6728	1.6340
1.9	4.78	4.0057	3.8231	3.6258	3.4783	3.3197	3.1987	3.0689	2.8617	2.6873	2.5402	2.4149	2.3064	2.2122	2.1293	2.0570	1.9936	1.9348	1.8819	1.8386	1.7962
2.0	5.03	4.3596	4.1623	3.9489	3.7895	3.6177	3.4868	3.3463	3.1217	2.9327	2.7732	2.6372	2.5195	2.4172	2.3272	2.2486	2.1797	2.1158	2.0583	2.0112	1.9650
2.1	5.29	4.7258	4.5133	4.2835	4.1116	3.9265	3.7853	3.6337	3.3913	3.1872	3.0148	2.8680	2.7407	2.6301	2.5326	2.4476	2.3730	2.3039	2.2416	2.1905	2.1405
2.2	5.54	5.1041	4.8760	4.6293	4.4447	4.2458	4.0940	3.9310	3.6704	3.4507	3.2651	3.1069	2.9698	2.8506	2.7455	2.6539	2.5734	2.4988	2.4316	2.3765	2.3226
2.3	5.79	5.4944	5.2504	4.9862	4.7886	4.5755	4.4129	4.2382	3.9587	3.7231	3.5239	3.3541	3.2068	3.0788	2.9659	2.8674	2.7809	2.7007	2.6284	2.5691	2.5111
2.4	6.04	5.8966	5.6361	5.3542	5.1431	4.9156	4.7418	4.5551	4.2563	4.0042	3.7912	3.6094	3.4517	3.3145	3.1936	3.0881	2.9954	2.9094	2.8319	2.7683	2.7061
2.5	6.29	6.3104	6.0332	5.7331	5.5083	5.2658	5.0806	4.8817	4.5630	4.2941	4.0668	3.8727	3.7043	3.5578	3.4286	3.3158	3.2167	3.1249	3.0420	2.9740	2.9075
2.6	6.55	6.7359	6.4415	6.1227	5.8838	5.6262	5.4293	5.2177	4.8788	4.5927	4.3506	4.1440	3.9646	3.8085	3.6709	3.5506	3.4450	3.3470	3.2587	3.1862	3.1152
2.7	6.80	7.1728	6.8609	6.5230	6.2698	5.9965	5.7877	5.5633	5.2036	4.8998	4.6427	4.4231	4.2325	4.0666	3.9203	3.7924	3.6801	3.5759	3.4819	3.4047	3.3292
2.8	7.05	7.6211	7.2913	6.9339	6.6660	6.3768	6.1558	5.9182	5.5372	5.2153	4.9429	4.7101	4.5080	4.3320	4.1768	4.0411	3.9219	3.8113	3.7115	3.6296	3.5495
2.9	7.30	8.0806	7.7326	7.3553	7.0724	6.7670	6.5335	6.2823	5.8797	5.5393	5.2511	5.0049	4.7910	4.6047	4.4404	4.2967	4.1705	4.0533	3.9476	3.8608	3.7759
3.0	7.55	8.5514	8.1847	7.7871	7.4889	7.1669	6.9206	6.6557	6.2309	5.8717	5.5674	5.3074	5.0814	4.8847	4.7110	4.5592	4.4257	4.3018	4.1901	4.0983	4.0085
3.1	7.80	9.0332	8.6475	8.2292	7.9154	7.5765	7.3172	7.0383	6.5908	6.2123	5.8917	5.6175	5.3793	5.1717	4.9885	4.8284	4.6875	4.5568	4.4389	4.3420	4.2472
3.2	8.06	9.5259	9.1210	8.6815	8.3519	7.9957	7.7232	7.4299	6.9593	6.5612	6.2238	5.9353	5.6845	5.4660	5.2730	5.1043	4.9560	4.8183	4.6940	4.5919	4.4920
3.3	8.31	10.0296	9.6050	9.1440	8.7982	8.4244	8.1384	7.8305	7.3364	6.9183	6.5638	6.2605	5.9969	5.7672	5.5643	5.3870	5.2309	5.0861	4.9554	4.8480	4.7428
3.4	8.56	10.5441	10.0994	9.6166	9.2543	8.8626	8.5628	8.2401	7.7220	7.2834	6.9115	6.5933	6.3167	6.0755	5.8625	5.6763	5.5124	5.3603	5.2229	5.1101	4.9997
3.5	8.81	11.0694	10.6043	10.0992	9.7201	9.3102	8.9964	8.6586	8.1161	7.6567	7.2670	6.9336	6.6436	6.3908	6.1675	5.9722	5.8003	5.6408	5.4967	5.3784	5.2625
3.6	9.06	11.6053	11.1194	10.5918	10.1955	9.7671	9.4391	9.0859	8.5185	8.0379	7.6302	7.2813	6.9777	6.7131	6.4792	6.2747	6.0947	5.9275	5.7766	5.6526	5.5312
3.7	9.31	12.1518	11.6449	11.0942	10.6806	10.2333	9.8908	9.5219	8.9293	8.4272	8.0011	7.6363	7.3190	7.0422	6.7977	6.5837	6.3954	6.2206	6.0627	5.9329	5.8059
3.8	9.57	12.7088	12.1805	11.6064	11.1752	10.7088	10.3515	9.9667	9.3484	8.8243	8.3795	7.9987	7.6673	7.3782	7.1228	6.8993	6.7025	6.5198	6.3548	6.2192	6.0864
3.9	9.82	13.2763	12.7262	12.1284	11.6793	11.1934	10.8212	10.4202	9.7757	9.2293	8.7655	8.3683	8.0226	7.7211	7.4545	7.2213	7.0160	6.8252	6.6530	6.5115	6.3728
4.0	10.07	13.8541	13.2820	12.6601	12.1927	11.6871	11.2997	10.8823	10.2112	9.6422	9.1591	8.7452	8.3850	8.0707	7.7929	7.5497	7.3357	7.1368	6.9572	6.8096	6.6650
4.1	10.32	14.4423	13.8477	13.2014	12.7156	12.1898	11.7870	11.3529	10.6548	10.0628	9.5601	9.1293	8.7543	8.4271	8.1378	7.8846	7.6616	7.4545	7.2675	7.1137	6.9631
4.2	10.57	15.0407	14.4235	13.7523	13.2477	12.7016	12.2831	11.8320	11.1066	10.4912	9.9685	9.5206	9.1306	8.7902	8.4893	8.2258	7.9939	7.7783	7.5837	7.4236	7.2668
4.3	10.82	15.6494	15.0090	14.3127	13.7891	13.2223	12.7879	12.3197	11.5664	10.9273	10.3844	9.9190	9.5137	9.1601	8.8472	8.5734	8.3323	8.1082	7.9058	7.7394	7.5764
4.4	11.08	16.2681	15.6045	14.8826	14.3397	13.7520	13.3014	12.8157	12.0343	11.3711	10.8076	10.3245	9.9038	9.5365	9.2117	8.9273	8.6769	8.4441	8.2339	8.0610	7.8916
4.5	11.33	16.8970	16.2096	15.4619	14.8995	14.2905	13.8236	13.3202	12.5101	11.8225	11.2381	10.7371	10.3007	9.9197	9.5826	9.2875	9.0276	8.7860	8.5678	8.3884	8.2125
4.6	11.58	17.5359	16.8246	16.0505	15.4683	14.8378	14.3543	13.8330	12.9939	12.2815	11.6759	11.1567	10.7043	10.3094	9.9600	9.6540	9.3845	9.1339	8.9076	8.7215	8.5391
4.7	11.83	18.1848	17.4491	16.6485	16.0462	15.3939	14.8936	14.3541	13.4856	12.7481	12.1210	11.5833	11.1148	10.7057	10.3437	10.0267	9.7474	9.4878	9.2533	9.0604	8.8714
4.8	12.08	18.8436	18.0833	17.2558	16.6332	15.9587	15.4414	14.8834	13.9851	13.2222	12.5734	12.0169	11.5320	11.1085	10.7338	10.4056	10.1164	9.8476	9.6048	9.4050	9.2093

Continued on next page

Recommended Head Loss Design Range

Sizing in this region will lead to excessive head loss conditions.

Appendix E

MLC Hydronic Friction Loss Tables

1" Uponor MLC — 50% Propylene Glycol — Feet of Head per 100 Feet of Tubing

Velocity (ft./sec.)	GPM	40°F 4°C	45°F 7°C	50°F 10°C	55°F 13°C	60°F 16°C	65°F 18°C	70°F 21°C	80°F 27°C	90°F 32°C	100°F 38°C	110°F 43°C	120°F 49°C	130°F 54°C	140°F 60°C	150°F 66°C	160°F 71°C	170°F 77°C	180°F 82°C	190°F 88°C	200°F 93°C
4.9	12.33	19.5123	18.7271	17.8723	17.2291	16.5322	15.9977	15.4210	14.4925	13.7037	13.0329	12.4575	11.9559	11.5179	11.1302	10.7907	10.4915	10.2134	9.9621	9.7553	9.5528
5.0	12.59	20.1909	19.3804	18.4980	17.8340	17.1144	16.5624	15.9668	15.0077	14.1928	13.4996	12.9049	12.3865	11.9337	11.5330	11.1819	10.8726	10.5850	10.3251	10.1113	9.9018
5.1	12.84	20.8792	20.0432	19.1329	18.4477	17.7051	17.1354	16.5207	15.5306	14.6893	13.9735	13.3593	12.8238	12.3561	11.9420	11.5793	11.2597	10.9625	10.6939	10.4730	10.2565
5.2	13.09	21.5772	20.7154	19.7769	19.0703	18.3045	17.7169	17.0828	16.0613	15.1931	14.4544	13.8205	13.2677	12.7848	12.3573	11.9828	11.6528	11.3459	11.0685	10.8403	10.6167
5.3	13.34	22.2850	21.3970	20.4299	19.7017	18.9124	18.3066	17.6529	16.5997	15.7044	14.9424	14.2885	13.7183	13.2200	12.7789	12.3924	12.0518	11.7350	11.4487	11.2132	10.9824
5.4	13.59	23.0024	22.0880	21.0919	20.3419	19.5288	18.9047	18.2311	17.1457	16.2230	15.4375	14.7633	14.1754	13.6616	13.2067	12.8081	12.4567	12.1300	11.8347	11.5917	11.3536
5.5	13.85	23.7294	22.7883	21.7630	20.9908	20.1536	19.5110	18.8173	17.6994	16.7488	15.9396	15.2450	14.6390	14.1095	13.6407	13.2298	12.8676	12.5308	12.2263	11.9758	11.7303
5.6	14.10	24.4660	23.4979	22.4430	21.6484	20.7869	20.1255	19.4115	18.2607	17.2820	16.4488	15.7333	15.1093	14.5638	14.0808	13.6575	13.2844	12.9373	12.6236	12.3655	12.1124
5.7	14.35	25.2122	24.2167	23.1319	22.3147	21.4285	20.7482	20.0137	18.8296	17.8224	16.9649	16.2284	15.5860	15.0245	14.5271	14.0913	13.7070	13.3496	13.0265	12.7607	12.5001
5.8	14.60	25.9678	24.9447	23.8297	22.9896	22.0786	21.3791	20.6238	19.4061	18.3701	17.4879	16.7303	16.0692	15.4914	14.9796	14.5310	14.1355	13.7677	13.4351	13.1614	12.8931
5.9	14.85	26.7329	25.6819	24.5363	23.6731	22.7369	22.0180	21.2417	19.9900	18.9250	18.0179	17.2387	16.5589	15.9646	15.4382	14.9767	14.5699	14.1914	13.8492	13.5677	13.2916
6.0	15.10	27.5073	26.4282	25.2517	24.3652	23.4036	22.6651	21.8676	20.5815	19.4870	18.5547	17.7539	17.0551	16.4441	15.9028	15.4284	15.0100	14.6208	14.2690	13.9794	13.6955
6.1	15.36	28.2912	27.1836	25.9759	25.0659	24.0785	23.3202	22.5013	21.1804	20.0562	19.0985	18.2757	17.5576	16.9298	16.3736	15.8859	15.4560	15.0560	14.6943	14.3966	14.1047
6.2	15.61	29.0844	27.9480	26.7089	25.7750	24.7617	23.9834	23.1427	21.7868	20.6325	19.6491	18.8041	18.0666	17.4217	16.8504	16.3494	15.9077	15.4967	15.1251	14.8193	14.5194
6.3	15.86	29.8869	28.7215	27.4506	26.4926	25.4531	24.6546	23.7920	22.4006	21.2159	20.2065	19.3391	18.5820	17.9199	17.3332	16.8188	16.3652	15.9432	15.5615	15.2474	14.9394
6.4	16.11	30.6987	29.5039	28.2009	27.2186	26.1526	25.3337	24.4491	23.0217	21.8065	20.7707	19.8807	19.1037	18.4242	17.8221	17.2941	16.8284	16.3952	16.0034	15.6809	15.3647
6.5	16.36	31.5197	30.2954	28.9599	27.9531	26.8604	26.0208	25.1138	23.6503	22.4040	21.3418	20.4289	19.6318	18.9347	18.3169	17.7752	17.2974	16.8529	16.4508	16.1199	15.7953
6.6	16.61	32.3500	31.0957	29.7275	28.6959	27.5762	26.7159	25.7863	24.2862	23.0086	21.9196	20.9835	20.1662	19.4513	18.8178	18.2622	17.7721	17.3161	16.9037	16.5642	16.2313
6.7	16.87	33.1894	31.9050	30.5037	29.4471	28.3001	27.4188	26.4664	24.9294	23.6202	22.5041	21.5447	20.7070	19.9741	19.3246	18.7549	18.2525	17.7849	17.3620	17.0139	16.6726
6.8	17.12	34.0379	32.7231	31.2885	30.2066	29.0321	28.1296	27.1542	25.5800	24.2389	23.0954	22.1124	21.2540	20.5030	19.8373	19.2535	18.7386	18.2593	17.8259	17.4690	17.1191
6.9	17.37	34.8956	33.5500	32.0818	30.9744	29.7722	28.8482	27.8497	26.2378	24.8644	23.6934	22.6866	21.8073	21.0379	20.3560	19.7579	19.2303	18.7393	18.2951	17.9295	17.5709
7.0	17.62	35.7623	34.3858	32.8836	31.7505	30.5203	29.5747	28.5527	26.9028	25.4970	24.2981	23.2672	22.3668	21.5790	20.8807	20.2681	19.7277	19.2248	18.7698	18.3953	18.0280
7.1	17.87	36.6381	35.2303	33.6939	32.5349	31.2763	30.3090	29.2633	27.5751	26.1364	24.9094	23.8543	22.9326	22.1261	21.4112	20.7840	20.2307	19.7158	19.2499	18.8664	18.4903
7.2	18.12	37.5229	36.0836	34.5126	33.3274	32.0404	31.0510	29.9815	28.2546	26.7828	25.5274	24.4477	23.5046	22.6793	21.9476	21.3057	20.7394	20.2123	19.7355	19.3429	18.9579
7.3	18.38	38.4167	36.9456	35.3398	34.1282	32.8124	31.8008	30.7073	28.9413	27.4361	26.1520	25.0476	24.0828	23.2385	22.4899	21.8331	21.2537	20.7143	20.2264	19.8246	19.4306
7.4	18.63	39.3195	37.8163	36.1753	34.9371	33.5923	32.5583	31.4405	29.6352	28.0962	26.7832	25.6539	24.6672	23.8037	23.0380	22.3662	21.7735	21.2218	20.7226	20.3117	19.9086
7.5	18.88	40.2312	38.6957	37.0192	35.7542	34.3801	33.3236	32.1813	30.3362	28.7632	27.4211	26.2666	25.2578	24.3749	23.5920	22.9051	22.2990	21.7348	21.2243	20.8040	20.3917
7.6	19.13	41.1518	39.5837	37.8715	36.5794	35.1758	34.0965	32.9295	31.0444	29.4370	28.0655	26.8856	25.8545	24.9520	24.1518	23.4496	22.8300	22.2532	21.7313	21.3016	20.8801
7.7	19.38	42.0813	40.4803	38.7321	37.4127	35.9793	34.8770	33.6851	31.7597	30.1177	28.7164	27.5109	26.4574	25.5352	24.7174	23.9998	23.3665	22.7770	22.2436	21.8044	21.3736
7.8	19.64	43.0197	41.3856	39.6010	38.2541	36.7907	35.6653	34.4483	32.4820	30.8051	29.3740	28.1426	27.0664	26.1243	25.2888	24.5556	23.9086	23.3063	22.7613	22.3125	21.8722
7.9	19.89	43.9668	42.2994	40.4782	39.1035	37.6099	36.4611	35.2188	33.2115	31.4993	30.0380	28.7805	27.6815	26.7193	25.8660	25.1171	24.4563	23.8410	23.2842	22.8258	22.3761
8.0	20.14	44.9228	43.2217	41.3636	39.9610	38.4369	37.2646	35.9967	33.9479	32.2003	30.7085	29.4248	28.3027	27.3203	26.4490	25.6843	25.0094	24.3811	23.8125	23.3443	22.8850

Recommended Head Loss Design Range

Sizing in this region will lead to excessive head loss conditions.

Appendix F: HDPE Hydronic Friction Loss Tables

Friction Loss Per 100 Feet
3/4" HDPE - SDR11 (100% Water)

Head (Feet of Water) Per 100 Feet of Tubing									
gpm	Velocity (ft/s)	40°F 4°C	60°F 16°C	80°F 27°C	100°F 38°C	120°F 49°C	140°F 60°C	160°F 71°C	180°F 82°C
0.5	0.28	0.07	0.07	0.06	0.06	0.06	0.06	0.06	0.06
1.0	0.55	0.27	0.25	0.23	0.23	0.22	0.21	0.20	0.20
1.5	0.83	0.56	0.52	0.49	0.48	0.46	0.44	0.43	0.43
2.0	1.10	0.96	0.89	0.84	0.81	0.78	0.75	0.74	0.72
2.5	1.38	1.45	1.34	1.27	1.23	1.17	1.14	1.12	1.09
3.0	1.66	2.03	1.88	1.78	1.72	1.64	1.60	1.56	1.53
4.0	2.21	3.46	3.20	3.04	2.93	2.80	2.72	2.66	2.61
5.0	2.76	5.23	4.83	4.59	4.43	4.23	4.10	4.02	3.94
6.0	3.31	7.33	6.77	6.43	6.20	5.92	5.75	5.64	5.53
7.0	3.87	9.75	9.00	8.55	8.25	7.87	7.65	7.50	7.35
8.0	4.42	12.48	11.52	10.95	10.56	10.08	9.79	9.60	9.41
9.0	4.97	15.52	14.33	13.61	13.13	12.54	12.18	11.94	11.70
10.0	5.52	18.86	17.41	16.54	15.96	15.23	14.80	14.51	14.22
11.0	6.08	22.50	20.77	19.73	19.04	18.17	17.65	17.31	16.96
12.0	6.63	26.43	24.39	23.17	22.36	21.34	20.73	20.33	19.92
13.0	7.18	30.64	28.29	26.87	25.93	24.75	24.04	23.57	23.10
14.0	7.73	35.15	32.44	30.82	29.74	28.39	27.58	27.04	26.50
15.0	8.28	39.93	36.86	35.02	33.79	32.25	31.33	30.72	30.10
16.0	8.84	45.00	41.54	39.46	38.07	36.34	35.31	34.61	33.92
17.0	9.39	50.34	46.47	44.14	42.59	40.66	39.50	38.72	37.95
18.0	9.94	55.95	51.65	49.07	47.34	45.19	43.90	43.04	42.18
19.0	10.49	61.84	57.08	54.23	52.32	49.95	48.52	47.57	46.62
20.0	11.05	67.99	62.76	59.63	57.53	54.92	53.35	52.30	51.26

Friction Loss Per 100 Feet
3/4" HDPE - SDR11 (30% Glycol)

Head (Feet of Water) Per 100 Feet of Tubing									
gpm	Velocity (ft/s)	40°F 4°C	60°F 16°C	80°F 27°C	100°F 38°C	120°F 49°C	140°F 60°C	160°F 71°C	180°F 82°C
0.5	0.28	0.09	0.08	0.08	0.08	0.07	0.07	0.07	0.07
1.0	0.55	0.33	0.30	0.29	0.28	0.27	0.26	0.25	0.25
1.5	0.83	0.70	0.65	0.61	0.59	0.56	0.55	0.54	0.53
2.0	1.10	1.19	1.10	1.04	1.01	0.96	0.93	0.92	0.90
2.5	1.38	1.80	1.66	1.58	1.52	1.45	1.41	1.38	1.36
3.0	1.66	2.52	2.33	2.21	2.13	2.04	1.98	1.94	1.90
4.0	2.21	4.29	3.96	3.76	3.63	3.47	3.37	3.30	3.24
5.0	2.76	6.49	5.99	5.69	5.49	5.24	5.09	4.99	4.89
6.0	3.31	9.09	8.39	7.97	7.69	7.34	7.13	6.99	6.85
7.0	3.87	12.09	11.16	10.60	10.23	9.76	9.49	9.30	9.11
8.0	4.42	15.48	14.29	13.57	13.10	12.50	12.14	11.91	11.67
9.0	4.97	19.25	17.77	16.88	16.28	15.54	15.10	14.80	14.51
10.0	5.52	23.39	21.59	20.51	19.79	18.89	18.35	17.99	17.63
11.0	6.08	27.90	25.75	24.46	23.61	22.53	21.89	21.46	21.03
12.0	6.63	32.77	30.25	28.74	27.73	26.47	25.71	25.21	24.70
13.0	7.18	38.00	35.08	33.32	32.15	30.69	29.82	29.23	28.65
14.0	7.73	43.58	40.23	38.22	36.88	35.20	34.20	33.53	32.86
15.0	8.28	49.52	45.71	43.42	41.90	39.99	38.85	38.09	37.33
16.0	8.84	55.80	51.50	48.93	47.21	45.07	43.78	42.92	42.06
17.0	9.39	62.42	57.62	54.74	52.82	50.41	48.97	48.01	47.05
18.0	9.94	69.38	64.04	60.84	58.71	56.04	54.44	53.37	52.30
19.0	10.49	76.68	70.78	67.24	64.88	61.93	60.16	58.98	57.80
20.0	11.05	84.31	77.83	73.94	71.34	68.10	66.15	64.86	63.56

Friction Loss Per 100 Feet
3/4" HDPE - SDR11 (40% Glycol)

Head (Feet of Water) Per 100 Feet of Tubing									
gpm	Velocity (ft/s)	40°F 4°C	60°F 16°C	80°F 27°C	100°F 38°C	120°F 49°C	140°F 60°C	160°F 71°C	180°F 82°C
0.5	0.28	0.10	0.09	0.09	0.08	0.08	0.08	0.08	0.07
1.0	0.55	0.35	0.33	0.31	0.30	0.29	0.28	0.27	0.27
1.5	0.83	0.75	0.69	0.66	0.63	0.61	0.59	0.58	0.57
2.0	1.10	1.28	1.18	1.12	1.08	1.03	1.00	0.98	0.96
2.5	1.38	1.93	1.78	1.69	1.63	1.56	1.51	1.48	1.46
3.0	1.66	2.70	2.50	2.37	2.29	2.18	2.12	2.08	2.04
4.0	2.21	4.60	4.25	4.04	3.90	3.72	3.61	3.54	3.47
5.0	2.76	6.96	6.42	6.10	5.89	5.62	5.46	5.35	5.25
6.0	3.31	9.75	9.00	8.55	8.25	7.87	7.65	7.50	7.35
7.0	3.87	12.97	11.97	11.37	10.97	10.47	10.17	9.97	9.78
8.0	4.42	16.60	15.32	14.56	14.05	13.41	13.03	12.77	12.51
9.0	4.97	20.64	19.05	18.10	17.47	16.67	16.20	15.88	15.56
10.0	5.52	25.08	23.16	22.00	21.23	20.26	19.68	19.30	18.91
11.0	6.08	29.92	27.62	26.24	25.32	24.17	23.48	23.02	22.56
12.0	6.63	35.15	32.44	30.82	29.74	28.39	27.58	27.04	26.50
13.0	7.18	40.76	37.62	35.74	34.49	32.92	31.98	31.35	30.72
14.0	7.73	46.75	43.15	40.99	39.55	37.76	36.68	35.96	35.24
15.0	8.28	53.11	49.03	46.57	44.94	42.90	41.67	40.85	40.04
16.0	8.84	59.85	55.24	52.48	50.64	48.34	46.96	46.04	45.11
17.0	9.39	66.95	61.80	58.71	56.65	54.07	52.53	51.50	50.47
18.0	9.94	74.42	68.69	65.26	62.97	60.11	58.39	57.24	56.10
19.0	10.49	82.24	75.92	72.12	69.59	66.43	64.53	63.27	62.00
20.0	11.05	90.43	83.48	79.30	76.52	73.04	70.95	69.56	68.17

Friction Loss Per 100 Feet
3/4" HDPE - SDR11 (50% Glycol)

Head (Feet of Water) Per 100 Feet of Tubing									
gpm	Velocity (ft/s)	40°F 4°C	60°F 16°C	80°F 27°C	100°F 38°C	120°F 49°C	140°F 60°C	160°F 71°C	180°F 82°C
0.5	0.28	0.10	0.10	0.09	0.09	0.08	0.08	0.08	0.08
1.0	0.55	0.37	0.34	0.33	0.32	0.30	0.29	0.29	0.28
1.5	0.83	0.79	0.73	0.69	0.67	0.64	0.62	0.61	0.60
2.0	1.10	1.34	1.24	1.18	1.14	1.09	1.05	1.03	1.01
2.5	1.38	2.03	1.88	1.78	1.72	1.64	1.59	1.56	1.53
3.0	1.66	2.85	2.63	2.50	2.41	2.30	2.23	2.19	2.15
4.0	2.21	4.85	4.47	4.25	4.10	3.92	3.80	3.73	3.65
5.0	2.76	7.32	6.76	6.42	6.20	5.92	5.75	5.63	5.52
6.0	3.31	10.26	9.47	9.00	8.68	8.29	8.05	7.89	7.74
7.0	3.87	13.65	12.60	11.97	11.55	11.02	10.71	10.50	10.29
8.0	4.42	17.47	16.13	15.32	14.79	14.11	13.71	13.44	13.17
9.0	4.97	21.73	20.06	19.05	18.39	17.55	17.05	16.71	16.38
10.0	5.52	26.41	24.37	23.16	22.34	21.33	20.72	20.31	19.91
11.0	6.08	31.50	29.07	27.62	26.65	25.44	24.71	24.23	23.74
12.0	6.63	37.00	34.15	32.44	31.31	29.88	29.03	28.46	27.89
13.0	7.18	42.90	39.60	37.62	36.30	34.65	33.66	33.00	32.34
14.0	7.73	49.21	45.42	43.15	41.64	39.74	38.61	37.85	37.09
15.0	8.28	55.91	51.61	49.03	47.31	45.15	43.86	43.00	42.14
16.0	8.84	63.00	58.15	55.24	53.30	50.88	49.43	48.46	47.49
17.0	9.39	70.47	65.05	61.80	59.63	56.92	55.29	54.21	53.13
18.0	9.94	78.33	72.31	68.69	66.28	63.27	61.46	60.26	59.05
19.0	10.49	86.57	79.91	75.92	73.25	69.92	67.93	66.59	65.26
20.0	11.05	95.19	87.87	83.48	80.55	76.88	74.69	73.22	71.76

Appendix F: HDPE Hydronic Friction Loss Tables

Friction Loss Per 100 Feet
1" HDPE - SDR11 (100% Water)

Head (Feet of Water) Per 100 Feet of Tubing									
gpm	Velocity (ft/s)	40°F 4°C	60°F 16°C	80°F 27°C	100°F 38°C	120°F 49°C	140°F 60°C	160°F 71°C	180°F 82°C
1.0	0.35	0.09	0.08	0.08	0.08	0.07	0.07	0.07	0.07
1.5	0.53	0.19	0.18	0.17	0.16	0.15	0.15	0.15	0.14
2.0	0.71	0.32	0.30	0.28	0.27	0.26	0.25	0.25	0.24
2.5	0.88	0.49	0.45	0.43	0.41	0.40	0.38	0.38	0.37
3.0	1.06	0.69	0.63	0.60	0.58	0.55	0.54	0.53	0.52
4.0	1.41	1.17	1.08	1.03	0.99	0.94	0.92	0.90	0.88
5.0	1.77	1.77	1.63	1.55	1.49	1.43	1.39	1.36	1.33
6.0	2.12	2.48	2.28	2.17	2.09	2.00	1.94	1.90	1.87
7.0	2.47	3.29	3.04	2.89	2.79	2.66	2.58	2.53	2.48
8.0	2.83	4.21	3.89	3.70	3.57	3.40	3.31	3.24	3.18
9.0	3.18	5.24	4.84	4.60	4.43	4.23	4.11	4.03	3.95
10.0	3.53	6.37	5.88	5.58	5.39	5.14	5.00	4.90	4.80
11.0	3.89	7.60	7.01	6.66	6.43	6.14	5.96	5.84	5.73
12.0	4.24	8.92	8.24	7.83	7.55	7.21	7.00	6.86	6.73
13.0	4.60	10.35	9.55	9.07	8.76	8.36	8.12	7.96	7.80
14.0	4.95	11.87	10.96	10.41	10.04	9.59	9.31	9.13	8.95
15.0	5.30	13.48	12.45	11.82	11.41	10.89	10.58	10.37	10.16
16.0	5.66	15.19	14.03	13.32	12.86	12.27	11.92	11.69	11.45
17.0	6.01	17.00	15.69	14.91	14.38	13.73	13.34	13.07	12.81
18.0	6.36	18.89	17.44	16.57	15.99	15.26	14.82	14.53	14.24
19.0	6.72	20.88	19.27	18.31	17.67	16.86	16.38	16.06	15.74
20.0	7.07	22.96	21.19	20.13	19.43	18.54	18.01	17.66	17.31
21.0	7.42	25.13	23.19	22.04	21.26	20.30	19.72	19.33	18.94
22.0	7.78	27.39	25.28	24.02	23.17	22.12	21.49	21.07	20.64
23.0	8.13	29.73	27.45	26.07	25.16	24.02	23.33	22.87	22.41
24.0	8.48	32.17	29.69	28.21	27.22	25.98	25.24	24.75	24.25
25.0	8.84	34.69	32.02	30.42	29.36	28.02	27.22	26.69	26.15
26.0	9.19	37.30	34.43	32.71	31.56	30.13	29.27	28.69	28.12
27.0	9.54	40.00	36.92	35.08	33.85	32.31	31.39	30.77	30.15
28.0	9.90	42.78	39.49	37.52	36.20	34.56	33.57	32.91	32.25
29.0	10.25	45.65	42.14	40.04	38.63	36.87	35.82	35.12	34.42
30.0	10.60	48.61	44.87	42.63	41.13	39.26	38.14	37.39	36.64

Friction Loss Per 100 Feet
1" HDPE - SDR11 (30% Glycol)

Head (Feet of Water) Per 100 Feet of Tubing									
gpm	Velocity (ft/s)	40°F 4°C	60°F 16°C	80°F 27°C	100°F 38°C	120°F 49°C	140°F 60°C	160°F 71°C	180°F 82°C
1.0	0.35	0.11	0.10	0.10	0.09	0.09	0.09	0.09	0.08
1.5	0.53	0.24	0.22	0.21	0.20	0.19	0.19	0.18	0.18
2.0	0.71	0.40	0.37	0.35	0.34	0.32	0.32	0.31	0.30
2.5	0.88	0.61	0.56	0.53	0.51	0.49	0.48	0.47	0.46
3.0	1.06	0.85	0.79	0.75	0.72	0.69	0.67	0.65	0.64
4.0	1.41	1.45	1.34	1.27	1.23	1.17	1.14	1.12	1.09
5.0	1.77	2.19	2.02	1.92	1.85	1.77	1.72	1.69	1.65
6.0	2.12	3.07	2.83	2.69	2.60	2.48	2.41	2.36	2.31
7.0	2.47	4.08	3.77	3.58	3.45	3.30	3.20	3.14	3.08
8.0	2.83	5.23	4.82	4.58	4.42	4.22	4.10	4.02	3.94
9.0	3.18	6.50	6.00	5.70	5.50	5.25	5.10	5.00	4.90
10.0	3.53	7.90	7.29	6.93	6.68	6.38	6.20	6.07	5.95
11.0	3.89	9.42	8.70	8.26	7.97	7.61	7.39	7.25	7.10
12.0	4.24	11.07	10.21	9.70	9.36	8.94	8.68	8.51	8.34
13.0	4.60	12.83	11.84	11.25	10.86	10.36	10.07	9.87	9.67
14.0	4.95	14.72	13.58	12.91	12.45	11.89	11.55	11.32	11.09
15.0	5.30	16.72	15.43	14.66	14.15	13.50	13.12	12.86	12.60
16.0	5.66	18.84	17.39	16.52	15.94	15.22	14.78	14.49	14.20
17.0	6.01	21.08	19.46	18.48	17.83	17.02	16.54	16.21	15.89
18.0	6.36	23.43	21.63	20.54	19.82	18.92	18.38	18.02	17.66
19.0	6.72	25.89	23.90	22.71	21.91	20.91	20.32	19.92	19.52
20.0	7.07	28.47	26.28	24.97	24.09	22.99	22.34	21.90	21.46
21.0	7.42	31.16	28.76	27.32	26.36	25.17	24.45	23.97	23.49
22.0	7.78	33.96	31.35	29.78	28.73	27.43	26.64	26.12	25.60
23.0	8.13	36.87	34.03	32.33	31.20	29.78	28.93	28.36	27.79
24.0	8.48	39.89	36.82	34.98	33.75	32.22	31.30	30.68	30.07
25.0	8.84	43.02	39.71	37.72	36.40	34.75	33.75	33.09	32.43
26.0	9.19	46.26	42.70	40.56	39.14	37.36	36.29	35.58	34.87
27.0	9.54	49.60	45.79	43.50	41.97	40.06	38.92	38.15	37.39
28.0	9.90	53.05	48.97	46.52	44.89	42.85	41.63	40.81	39.99
29.0	10.25	56.61	52.26	49.64	47.90	45.72	44.42	43.55	42.68
30.0	10.60	60.28	55.64	52.86	51.00	48.68	47.29	46.37	45.44

Appendix F: HDPE Hydronic Friction Loss Tables

Friction Loss Per 100 Feet
1" HDPE - SDR11 (40% Glycol)

Head (Feet of Water) Per 100 Feet of Tubing									
gpm	Velocity (ft/s)	40°F 4°C	60°F 16°C	80°F 27°C	100°F 38°C	120°F 49°C	140°F 60°C	160°F 71°C	180°F 82°C
1.0	0.35	0.12	0.11	0.10	0.10	0.10	0.09	0.09	0.09
1.5	0.53	0.25	0.23	0.22	0.21	0.20	0.20	0.19	0.19
2.0	0.71	0.43	0.40	0.38	0.36	0.35	0.34	0.33	0.33
2.5	0.88	0.65	0.60	0.57	0.55	0.53	0.51	0.50	0.49
3.0	1.06	0.91	0.84	0.80	0.77	0.74	0.72	0.70	0.69
4.0	1.41	1.55	1.44	1.36	1.32	1.26	1.22	1.20	1.17
5.0	1.77	2.35	2.17	2.06	1.99	1.90	1.84	1.81	1.77
6.0	2.12	3.29	3.04	2.89	2.79	2.66	2.58	2.53	2.48
7.0	2.47	4.38	4.04	3.84	3.70	3.54	3.44	3.37	3.30
8.0	2.83	5.61	5.17	4.92	4.74	4.53	4.40	4.31	4.23
9.0	3.18	6.97	6.43	6.11	5.90	5.63	5.47	5.36	5.25
10.0	3.53	8.47	7.82	7.43	7.17	6.84	6.65	6.52	6.39
11.0	3.89	10.10	9.33	8.86	8.55	8.16	7.93	7.77	7.62
12.0	4.24	11.87	10.96	10.41	10.04	9.59	9.31	9.13	8.95
13.0	4.60	13.76	12.70	12.07	11.65	11.12	10.80	10.59	10.37
14.0	4.95	15.78	14.57	13.84	13.36	12.75	12.38	12.14	11.90
15.0	5.30	17.93	16.55	15.73	15.17	14.48	14.07	13.80	13.52
16.0	5.66	20.21	18.65	17.72	17.10	16.32	15.86	15.54	15.23
17.0	6.01	22.61	20.87	19.82	19.13	18.26	17.74	17.39	17.04
18.0	6.36	25.13	23.19	22.04	21.26	20.30	19.72	19.33	18.94
19.0	6.72	27.77	25.63	24.35	23.50	22.43	21.79	21.36	20.94
20.0	7.07	30.54	28.19	26.78	25.84	24.66	23.96	23.49	23.02
21.0	7.42	33.42	30.85	29.31	28.28	26.99	26.22	25.71	25.19
22.0	7.78	36.42	33.62	31.94	30.82	29.42	28.58	28.02	27.46
23.0	8.13	39.55	36.50	34.68	33.46	31.94	31.03	30.42	29.81
24.0	8.48	42.78	39.49	37.52	36.20	34.56	33.57	32.91	32.25
25.0	8.84	46.14	42.59	40.46	39.04	37.27	36.20	35.49	34.78
26.0	9.19	49.61	45.80	43.51	41.98	40.07	38.93	38.16	37.40
27.0	9.54	53.20	49.11	46.65	45.02	42.97	41.74	40.92	40.11
28.0	9.90	56.90	52.53	49.90	48.15	45.96	44.65	43.77	42.90
29.0	10.25	60.72	56.05	53.25	51.38	49.04	47.64	46.71	45.77
30.0	10.60	64.65	59.68	56.69	54.70	52.22	50.73	49.73	48.74

Friction Loss Per 100 Feet
1" HDPE - SDR11 (50% Glycol)

Head (Feet of Water) Per 100 Feet of Tubing									
gpm	Velocity (ft/s)	40°F 4°C	60°F 16°C	80°F 27°C	100°F 38°C	120°F 49°C	140°F 60°C	160°F 71°C	180°F 82°C
1.0	0.35	0.13	0.12	0.11	0.11	0.10	0.10	0.10	0.09
1.5	0.53	0.27	0.25	0.23	0.23	0.22	0.21	0.21	0.20
2.0	0.71	0.45	0.42	0.40	0.38	0.37	0.36	0.35	0.34
2.5	0.88	0.69	0.63	0.60	0.58	0.55	0.54	0.53	0.52
3.0	1.06	0.96	0.89	0.84	0.81	0.78	0.75	0.74	0.72
4.0	1.41	1.64	1.51	1.44	1.38	1.32	1.28	1.26	1.23
5.0	1.77	2.47	2.28	2.17	2.09	2.00	1.94	1.90	1.86
6.0	2.12	3.47	3.20	3.04	2.93	2.80	2.72	2.67	2.61
7.0	2.47	4.61	4.25	4.04	3.90	3.72	3.62	3.55	3.47
8.0	2.83	5.90	5.45	5.17	4.99	4.77	4.63	4.54	4.45
9.0	3.18	7.34	6.77	6.43	6.21	5.93	5.76	5.64	5.53
10.0	3.53	8.92	8.23	7.82	7.54	7.20	7.00	6.86	6.72
11.0	3.89	10.64	9.82	9.33	9.00	8.59	8.34	8.18	8.02
12.0	4.24	12.49	11.53	10.96	10.57	10.09	9.80	9.61	9.42
13.0	4.60	14.49	13.37	12.70	12.26	11.70	11.37	11.14	10.92
14.0	4.95	16.62	15.34	14.57	14.06	13.42	13.04	12.78	12.53
15.0	5.30	18.88	17.43	16.55	15.97	15.25	14.81	14.52	14.23
16.0	5.66	21.27	19.64	18.65	18.00	17.18	16.69	16.36	16.04
17.0	6.01	23.80	21.97	20.87	20.14	19.22	18.67	18.30	17.94
18.0	6.36	26.45	24.42	23.19	22.38	21.36	20.75	20.35	19.94
19.0	6.72	29.23	26.98	25.63	24.74	23.61	22.94	22.49	22.04
20.0	7.07	32.14	29.67	28.19	27.20	25.96	25.22	24.72	24.23
21.0	7.42	35.18	32.47	30.85	29.77	28.41	27.60	27.06	26.52
22.0	7.78	38.34	35.39	33.62	32.44	30.97	30.08	29.49	28.90
23.0	8.13	41.63	38.42	36.50	35.22	33.62	32.66	32.02	31.38
24.0	8.48	45.04	41.57	39.49	38.11	36.38	35.34	34.64	33.95
25.0	8.84	48.57	44.83	42.59	41.10	39.23	38.11	37.36	36.61
26.0	9.19	52.22	48.21	45.80	44.19	42.18	40.98	40.17	39.37
27.0	9.54	56.00	51.69	49.11	47.39	45.23	43.94	43.08	42.22
28.0	9.90	59.90	55.29	52.53	50.68	48.38	47.00	46.08	45.15
29.0	10.25	63.92	59.00	56.05	54.08	51.62	50.15	49.17	48.18
30.0	10.60	68.05	62.82	59.68	57.58	54.97	53.40	52.35	51.30

Appendix G

Velocity Charts

Velocity Chart in Feet per Second
Wirsbo hePEX / Uponor AquaPEX Tubing

gpm	5/8"	3/4"
0.2	0.25	0.18
0.4	0.50	0.36
0.6	0.74	0.54
0.8	0.99	0.73
1.0	1.24	0.91
1.2	1.49	1.09
1.4	1.74	1.27
1.6	1.98	1.45
1.8	2.23	1.63
2.0	2.48	1.81
2.2	2.73	2.00
2.4	2.98	2.18
2.6	3.22	2.36
2.8	3.47	2.54
3.0	3.72	2.72
3.2	3.97	2.90
3.4	4.22	3.09
3.6	4.46	3.27
3.8	4.71	3.45
4.0	4.96	3.63
4.2	5.21	3.81
4.4	5.46	3.99
4.6	5.70	4.17
4.8	5.95	4.36
5.0	6.20	4.54
5.2	6.45	4.72
5.4	6.70	4.90
5.6	6.94	5.08
5.8	7.19	5.26
6.0	7.44	5.44
6.2	7.69	5.63
6.4	7.94	5.81
6.6	8.18	5.99
6.8	8.43	6.17
7.0	8.68	6.35
7.2	8.93	6.53
7.4	9.18	6.71
7.6	9.42	6.90
7.8	9.67	7.08
8.0	9.92	7.26
8.2	10.17	7.44
8.4	10.42	7.62
8.6	10.66	7.80
8.8	10.91	7.99
9.0	11.16	8.17
9.2	11.41	8.35
9.4	11.66	8.53
9.6	11.90	8.71
9.8	12.15	8.89
10.0	12.40	9.07

gpm	1"	1 1/4"	1 1/2"
4.0	2.20	1.47	1.06
4.2	2.31	1.54	1.11
4.4	2.42	1.62	1.16
4.6	2.53	1.69	1.21
4.8	2.64	1.77	1.27
5.0	2.75	1.84	1.32
5.2	2.86	1.91	1.37
5.4	2.97	1.99	1.43
5.6	3.08	2.06	1.48
5.8	3.19	2.13	1.53
6.0	3.30	2.21	1.58
6.2	3.41	2.28	1.64
6.4	3.52	2.35	1.69
6.6	3.63	2.43	1.74
6.8	3.74	2.50	1.80
7.0	3.85	2.57	1.85
7.2	3.96	2.65	1.90
7.4	4.07	2.72	1.95
7.6	4.18	2.80	2.01
7.8	4.29	2.87	2.06
8.0	4.40	2.94	2.11
8.2	4.51	3.02	2.16
8.4	4.62	3.09	2.22
8.6	4.73	3.16	2.27
8.8	4.84	3.24	2.32
9.0	4.95	3.31	2.38
9.2	5.06	3.38	2.43
9.4	5.17	3.46	2.48
9.6	5.28	3.53	2.53
9.8	5.39	3.60	2.59
10.0	5.50	3.68	2.64
10.2	5.61	3.75	2.69
10.4	5.72	3.82	2.75
10.6	5.83	3.90	2.80
10.8	5.94	3.97	2.85
11.0	6.05	4.05	2.90
11.2	6.16	4.12	2.96
11.4	6.27	4.19	3.01
11.6	6.38	4.27	3.06
11.8	6.49	4.34	3.12
12.0	6.60	4.41	3.17
12.2	6.71	4.49	3.22
12.4	6.82	4.56	3.27
12.6	6.93	4.63	3.33
12.8	7.04	4.71	3.38
13.0	7.15	4.78	3.43
13.2	7.26	4.85	3.48
13.4	7.37	4.93	3.54
13.6	7.48	5.00	3.59
13.8	7.59	5.08	3.64
14.0	7.70	5.15	3.70

Maintain a minimum velocity of 1.5 ft/sec.

Velocities in excess of 8 ft/sec may cause erosion to metal components in the system.

Velocity Chart in Feet per Second MLC Tubing

gpm	5/8"	3/4"	1"	gpm	5/8"	3/4"	1"
0.1	0.10	0.07	0.04	5.2	5.40	3.39	2.07
0.2	0.21	0.13	0.08	5.4	5.61	3.52	2.15
0.3	0.31	0.20	0.12	5.6	5.82	3.65	2.23
0.4	0.42	0.26	0.16	5.8	6.03	3.78	2.30
0.5	0.52	0.33	0.20	6.0	6.24	3.91	2.38
0.6	0.62	0.39	0.24	6.2	6.44	4.04	2.46
0.7	0.73	0.46	0.28	6.4	6.65	4.17	2.54
0.8	0.83	0.52	0.32	6.6	6.86	4.30	2.62
0.9	0.94	0.59	0.36	6.8	7.07	4.43	2.70
1.0	1.04	0.65	0.40	7.0	7.27	4.56	2.78
1.1	1.14	0.72	0.44	7.2	7.48	4.69	2.86
1.2	1.25	0.78	0.48	7.4	7.69	4.82	2.94
1.3	1.35	0.85	0.52	7.6	7.90	4.95	3.02
1.4	1.45	0.91	0.56	7.8	8.11	5.08	3.10
1.5	1.56	0.98	0.60	8.0	8.31	5.21	3.18
1.6	1.66	1.04	0.64	8.2	8.52	5.34	3.26
1.7	1.77	1.11	0.68	8.4	8.73	5.47	3.34
1.8	1.87	1.17	0.72	8.6	8.94	5.60	3.42
1.9	1.97	1.24	0.75	8.8	9.15	5.73	3.50
2.0	2.08	1.30	0.79	9.0	9.35	5.86	3.58
2.1	2.18	1.37	0.83	9.2	9.56	5.99	3.66
2.2	2.29	1.43	0.87	9.4	9.77	6.12	3.74
2.3	2.39	1.50	0.91	9.6	9.98	6.25	3.81
2.4	2.49	1.56	0.95	9.8	10.18	6.38	3.89
2.5	2.60	1.63	0.99	10.0	10.39	6.51	3.97
2.6	2.70	1.69	1.03	10.2	10.60	6.64	4.05
2.7	2.81	1.76	1.07	10.4	10.81	6.77	4.13
2.8	2.91	1.82	1.11	10.6	11.02	6.90	4.21
2.9	3.01	1.89	1.15	10.8	11.22	7.03	4.29
3.0	3.12	1.95	1.19	11.0	11.43	7.16	4.37
3.1	3.22	2.02	1.23	11.2	11.64	7.29	4.45
3.2	3.33	2.08	1.27	11.4	11.85	7.43	4.53
3.3	3.43	2.15	1.31	11.6	12.06	7.56	4.61
3.4	3.53	2.21	1.35	11.8	12.26	7.69	4.69
3.5	3.64	2.28	1.39	12.0	12.47	7.82	4.77
3.6	3.74	2.34	1.43	12.2	12.68	7.95	4.85
3.7	3.85	2.41	1.47	12.4	12.89	8.08	4.93
3.8	3.95	2.48	1.51	12.6	13.09	8.21	5.01
3.9	4.05	2.54	1.55	12.8	13.30	8.34	5.09
4.0	4.16	2.61	1.59	13.0	13.51	8.47	5.17
4.1	4.26	2.67	1.63	13.2	13.72	8.60	5.25
4.2	4.36	2.74	1.67	13.4	13.93	8.73	5.32
4.3	4.47	2.80	1.71	13.6	14.13	8.86	5.40
4.4	4.57	2.87	1.75	13.8	14.34	8.99	5.48
4.5	4.68	2.93	1.79	14.0	14.55	9.12	5.56
4.6	4.78	3.00	1.83	14.2	14.76	9.25	5.64
4.7	4.88	3.06	1.87	14.4	14.97	9.38	5.72
4.8	4.99	3.13	1.91	14.6	15.17	9.51	5.80
4.9	5.09	3.19	1.95	14.8	15.38	9.64	5.88
5.0	5.20	3.26	1.99	15.0	15.59	9.77	5.96

Maintain a minimum velocity of 1.5 ft/sec.

Velocities in excess of 8 ft/sec may cause erosion to metal components in the system.

Velocity Chart in Feet per Second
High Density Polyethylene (HDPE) SDR 11

gpm	2"	3"	4"
15	1.71	0.79	0.48
20	2.29	1.05	0.64
25	2.86	1.31	0.80
30	3.43	1.58	0.95
35	4.00	1.84	1.11
40	4.57	2.10	1.27
45	5.14	2.37	1.43
50	5.71	2.63	1.59
55	6.28	2.89	1.75
60	6.86	3.15	1.91
65	7.43	3.42	2.07
70	8.00	3.68	2.23
75	8.57	3.94	2.39
80	9.14	4.20	2.54
85	9.71	4.47	2.70
90	10.28	4.73	2.86
95	10.85	4.99	3.02
100	11.43	5.26	3.18
105	12.00	5.52	3.34
110	12.57	5.83	3.50
115	13.14	6.04	3.66
120	13.71	6.31	3.82
125	14.28	6.57	3.98
130	14.85	6.83	4.13
135	15.42	7.10	4.29
140	16.00	7.36	4.45
145	16.57	7.62	4.61
150	17.14	7.88	4.77
155	17.71	8.15	4.93
160	18.28	8.41	5.09
165	18.85	8.67	5.25
170	19.42	8.94	5.41
175	19.99	9.20	5.57
180	20.57	9.46	5.73
185	21.14	9.72	5.88
190	21.71	9.99	6.04
195	22.28	10.25	6.20
200	22.85	10.51	6.36
205	23.42	10.78	6.52
210	23.99	11.04	6.68
215	24.56	11.30	6.84
220	25.14	11.56	7.00
225	25.71	11.83	7.16
230	26.28	12.09	7.32
235	26.85	12.35	7.47
240	27.42	12.61	7.63
245	27.99	12.88	7.79
250	28.56	13.14	7.95

■ Maintain a minimum velocity of 1.5 ft/sec.

■ Velocities in excess of 8 ft/sec may cause erosion to metal components in the system.

Appendix H

Variable Speed Injection Mixing

The purpose of this appendix is to discuss the use of variable speed injection mixing to precisely transfer heat from the high temperature boiler (primary) loop to the lower temperature radiant (secondary) loop in hydronic heating systems.

Various devices and plumbing arrangements can be used to accomplish this transfer. In the past, it was common to use a mixing valve in order to temper the water between the primary and secondary loops in a system. In some instances, the heat source (condensing or electric boiler, geo-thermal heat pump, etc.) can be operated at lower temperatures and dedicated solely to operating a low temperature radiant heating system. In the vast majority of systems, mixing is required because:

- A boiler minimum operating temperature is required.
- High temperature water is required for other system needs.
- Water temperatures vary over a wide range (e.g. solar heat sources, waste heat utilization, wood fired boilers, etc.).

When the available heat source produces higher water temperatures than is required by the snow and ice melting system, a tempering device is required. To achieve the lower water temperature required for the system, the high temperature boiler water must be blended or injected into the return side of the snow and ice melting system to a level that meets the required supply water temperature for the radiant side. Technologies have evolved to the point of using small wet-rotor pumps to accurately adjust the secondary radiant supply water temperature regardless of the flow activities on either primary or secondary loops (see **Figure H-1**).

The speed of the injection pump is automatically adjusted to deliver the desired volume of hot boiler water to the lower temperature radiant loop. The injection pump speed is constantly adjusted as the snow and ice melting system demand and the supply water temperature change. If the boiler return temperature becomes too cold, the injection pump can be slowed down to reduce the heat injection rate, resulting in an increased boiler return temperature.

Uponor offers a variety of controls that use variable speed injection pump output. This output modulates the power supply to the circulator to vary its rotational speed. For residential and many commercial systems, the controls have a 120VAC 50/60Hz output to directly power small circulators.

A permanent capacitor, impedance-protected motor (no start switch) on the circulator is required. The maximum allowable amperage for this output is 2.2 amps, which limits the allowable circulator size to $\frac{1}{6}$ HP.

This type of system can use a small circulator to inject a high BTU/h input into a relatively large system flow. Typically, the injection pump need only deliver $\frac{1}{6}$ to $\frac{1}{4}$ of the system flow for low temperature radiant panels if high temperature water is available for injection. In small hydronic systems, the smallest available circulator for variable speed injection may be too large. It is important to properly size the injection pump and use a globe valve on the return injection leg.

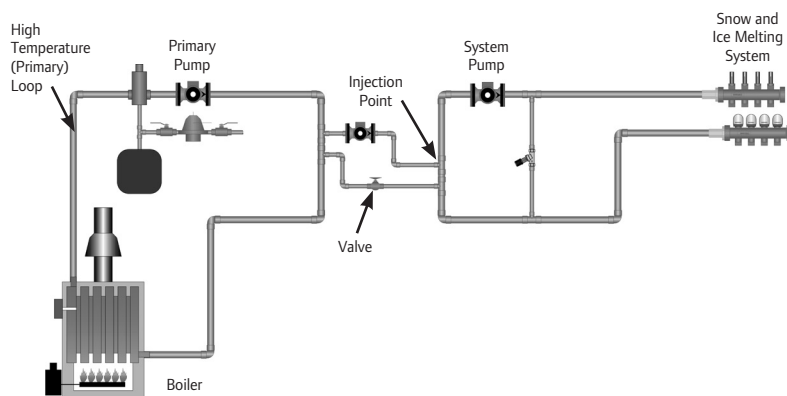

Figure H-1 Mixing with variable speed pump

For proper injection pump sizing, the designer must know the following information (see **Figure H-2**).

F_v = Flow Rate (Injection Loop) in gpm

F_1 = Radiant (Secondary Loop) Flow Rate in gpm

T_1 = Boiler (Primary Loop) Supply Temperature

T_2 = Radiant (Secondary Loop) Supply Temperature

T_R = Radiant (Secondary Loop) Return Temperature

T_b = Radiant (Secondary Loop) Temperature
Differential ($T_2 - T_R$)

Note: All values are to be given at design conditions. The formula used for sizing the injection pump is shown below.

$$F_v = (F_1 \times T_b) / (T_1 - T_R)$$

Example

If values at design conditions are:

F_1 = Radiant (Secondary) Flow = 30 gpm

T_1 = Boiler (Primary) Supply = 180°F

T_2 = Radiant (Secondary) Supply = 140°F

T_R = Radiant (Secondary) Return = 120°F

T_b = Radiant (Secondary) Differential = 20°F

To find the injection pump flow rate:

$$F_v = (30 \times 20) / (180 - 120)$$

$$F_v = (600) / (60)$$

$$F_v = 10 \text{ gpm}$$

In order to provide the proper amount and temperature of supply water on the radiant heating loop, the variable speed injection pump needs only to inject 10 gpm at design conditions.

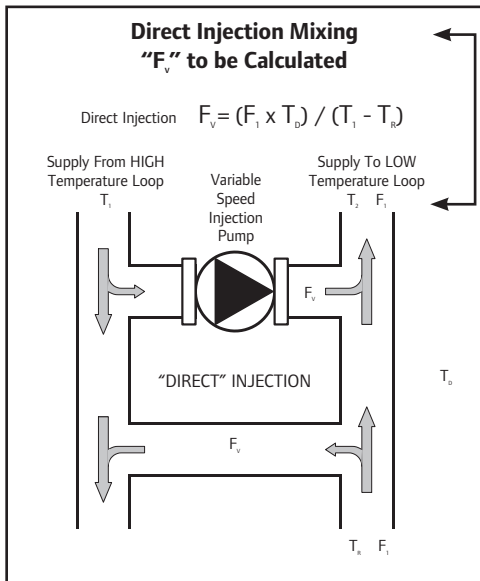
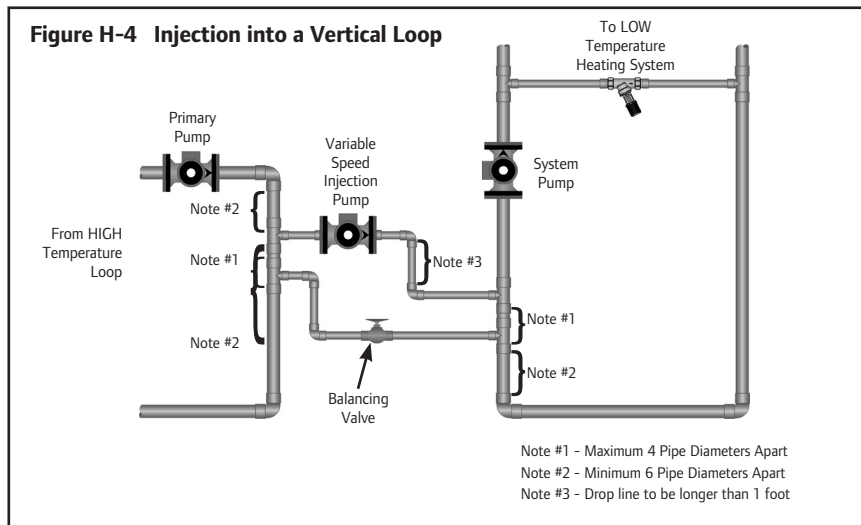
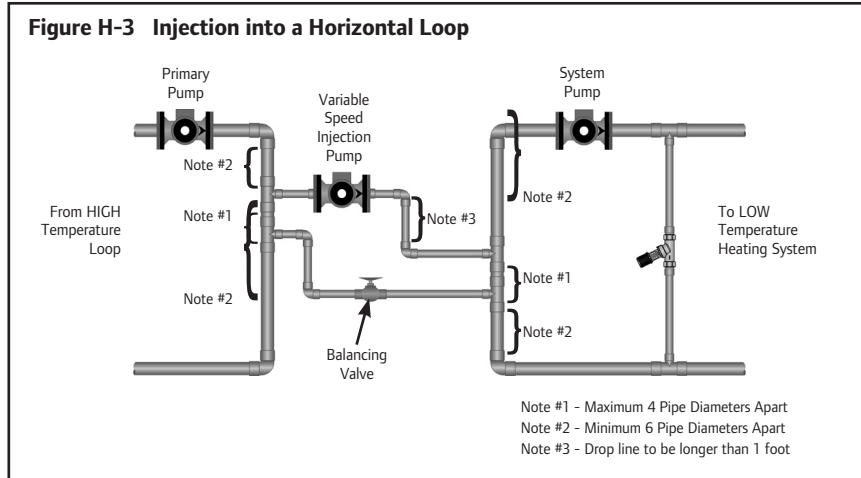

Figure H-2

Figures H-3 and H-4 show the two most common piping layouts for variable speed injection mixing. Pay particular attention to the drop lines (or thermal traps) shown in the injection legs. These are particularly important to prevent “thermal siphoning” from the primary loop into the secondary loop. Consult the pump manufacturers’ chart (below) to assist in the selection of the proper injection pump for the project.

In the piping arrangement shown, the variable speed injection pumps are plumbed this way to limit head pressure in the injection legs to only a few feet at most. Use standard pressure drop calculations and equivalent length of feet charts for exact calculations, if required.



Variable Speed Injection Design Flow Rates

Design Injection Without Globe Valve	Flow Rate (gpm) With Globe Valve	Turns Open of the Globe Valve (%)	Nominal Pipe Diameter (inches)	Manufacturer Approved Pump Models										
				Grundfos (F)				Taco			B&G		Armstrong	
				15-42	26-64	43-75	003	007	0010	0012	NRF 9	NRF 22	NRF 33	Astro
2*	3**										30	50		
–	1.5–2.0	20	0.5	X	X				X				X	
2.5	2	100	0.5				X							
4–5.5	3.0–4.5	100	0.5	X	X			X			X	X		X
4.5–6.5	4–5.5	100	0.75				X				X			
9–10.5	7.5–8.5	100	0.75		X			X						X
9	8	100	1							X				
14–15	12–13	100	1		X			X			X			
19	17	100	1.25											X
22–24	19–21	100	1.25			X			X				X	
26–28	–	100	1.5			X			X				X	
35–37	31–32	100	1.5				X			X				
33	30	100	2									X		
41–45	39–42	100	2				X			X				

* Speed 2, ** Speed 3 (Brute)

Table courtesy of tekmar - This table assumes 5 feet of pipe, four elbows and branch trees of the listed diameter. These circulators have been tested and approved by the manufacturers for use with the Uponor pro Series controls.

Appendix I

Conversion Factors

TO CONVERT FROM	TO	MULTIPLY BY
PRESSURE		
Atmospheres	feet of water	33.9
Atmospheres	mm. of mercury	760.0
Atmospheres	pounds/sq. in.	14.696
Feet of water (40°F)	pounds/sq. in.	0.4335
Inches of mercury (32°F)	feet of water (40°F)	1.133
Inches of mercury (32°F)	pounds/sq. in.	0.49116
Inches of water (40°F)	pounds/sq. in.	0.03614
mm. of mercury (32°F)	pounds/sq. in.	0.1934
Pounds/sq. in.	feet of water (40°F)	2.3066
Pounds/sq. in.	inches of mercury (32°F)	2.036
VOLUME		
Barrels (oil)	gallons	42.0
Barrels (brewery)	gallons	31.0
Cubic cm	cubic inches	0.061023
Cubic feet	cubic inches	1728.0
Cubic feet	cubic meters	0.02832
Cubic feet	gallons	7.481
Cubic meters	gallons	264.17
Gallons	cubic feet	0.1337
Gallons	cubic inches	231.0
Gallons	gallons (British)	0.83268
Gallons	liters	3.7853
Liters	gallons	0.2642
Liters	quarts	1.0567
HEAT		
Boiler horsepower (BHP)	BTU/h	33479.0
BTU/h	calories (gram)	252.0
BTU/h	calories (kg.)	0.252
Calories (gram) gram/°C	BTU/lb/°F	1.0
Calories (gram) per gram	BTU/lb	1.8
Horsepower	BTU/h	2545.0
K.W. hours	BTU	3413.0

TO CONVERT FROM	TO	MULTIPLY BY
TEMPERATURE		
Centigrade degrees	Fahrenheit degrees	1.8 and add 32°
Fahrenheit degrees	Centigrade degrees	Subtract 32° and multiply by 0.5555
MEASUREMENT		
Centimeters	inches	0.3937
Feet	meters	0.3048
Inches	centimeters	2.54
Kilometers	miles	0.6214
Meters	feet	3.2808
Microns	millimeters	0.001
Sq. meters	sq. feet	10.764
WEIGHT		
Cubic ft. of water (60°F)	pounds	62.37
Gallons	pounds of water (60°F)	8.34
Grains	pounds	1/7000
Grains/gallon	parts per million	17.12
Grams	grains	15.43
Kilograms	pounds	2.2046
Pounds	grams	453.59
Pounds	kilograms	0.4536
Tons (long)	tons (short)	1.12
VOLUMETRIC RATE		
Cubic ft./sec	gallons/min	448.83
Gallons/min	cu. ft./sec	0.00223
POWER		
Horsepower	ft lbs/sec	550.0
Horsepower	K.W.	0.745
VISCOSITY		
Centipoises	lbs/sec/ft	0.000672
Poises	centipoises	0.01
VELOCITY		
ft/sec	meters/sec	0.3048
Meters/sec	ft/sec	3.2808

Notes

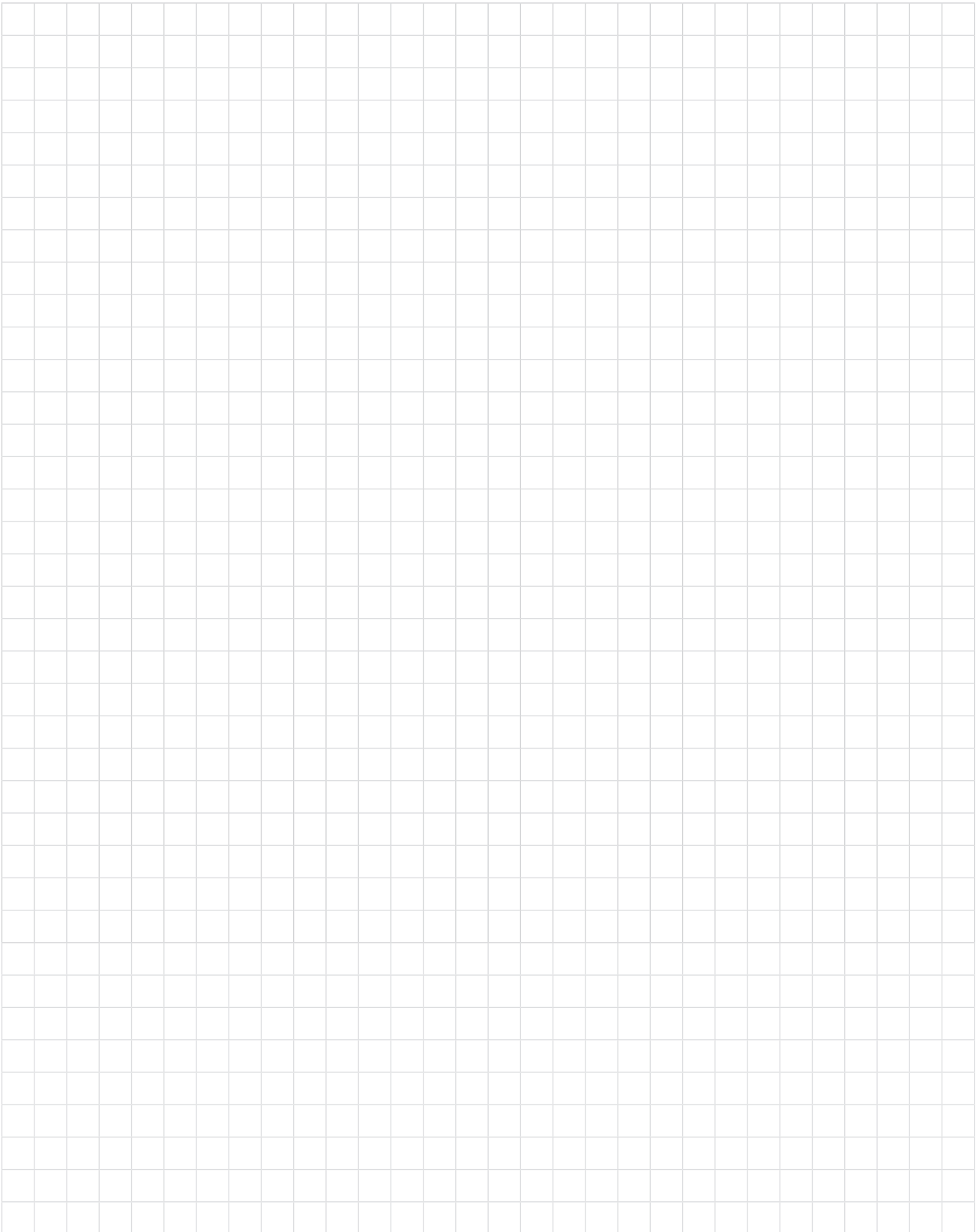

Uponor, Inc.
5925 148th Street West
Apple Valley, MN 55124 USA
Tel: 800.321.4739
Fax: 952.891.2008

Uponor Ltd.
2000 Argentia Rd., Plaza 1, Ste. 200
Mississauga, ON L5N 1W1 CANADA
Tel: 888.994.7726
Fax: 800.638.9517

uponor

uponorpro.com

uponor

Snow and Ice Melting Design Manual

4th Edition